

KINNEY® KLRC

Two-Stage Liquid Ring Vacuum Pumps

Models: KLRC-40 KLRC-75

Features:

- Impellers positively locked to shaft
- Reliable mechanical seals for high-integrity sealing and low shaft friction
- Center-anchored tie rods allow access to either end of the pump without total disassembly
- Precision casting and CNC machining eliminates the need for body gasketing (process dependent)
- Replaceable end plates
- Clearance adjustments via shims
- Made in the USA

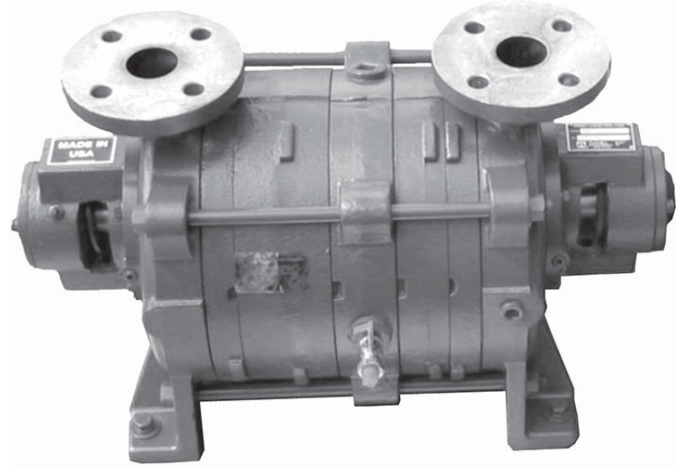

KLRC - 40/75 Material & Seal Code		
KLRC-40/75 XY	X	Material code
	Y	Mechanical seal code
Material Code (X)	B	Cast iron casings, bronze impellers, SS316 shaft
	F	Cast iron casings, SS316L impellers & SS316 shaft
	C	All wetted parts SS316L & SS316 shaft
Mechanical Seal Code (Y)	A	John Crane Type 21 Carbon/Ceramic/Viton
	D	Flowserve Type RO Carbon/Durchrome/Viton.
	L	Teflon encapsulated Viton O-Rings
Consult factory for alternate seal configurations		

Specifications	KLRC-40		KLRC-75	
Motor	60 Hz	50 Hz	60 Hz	50 Hz
	5 HP	4 KW	5 HP	4 KW
	1750 RPM	1450 RPM	1750 RPM	1450 RPM
Seal Water Flow	5 GPM			
Noise Level	69 dBA @ 75 Torr (3 ft)			
Maximum Allowable Suction Temperature	220°F (Hot Pump)			
Maximum Seal Water Temperature	175° F			

Typical Pumping Speed Curves

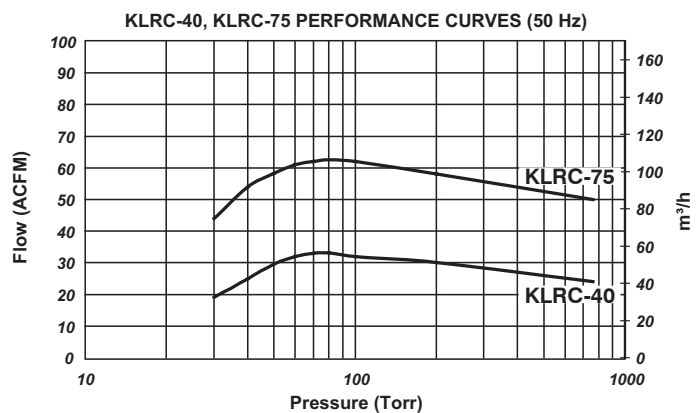
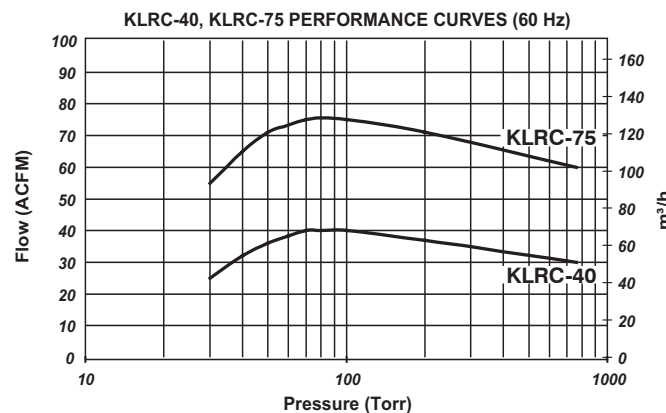

- 1.) Above performance data based on 68° F inlet air with 50% relative humidity and using water as a sealant at 60° F.
- 2.) All SS pump capacity less 10%

Your Local Tuthill Vacuum & Blower Systems Sales Professional:

LEADING THE SEARCH FOR NEW SOLUTIONS



TUTHILL
Vacuum & Blower Systems

4840 West Kearney Street, P. O. Box 2877
Springfield, Missouri USA 65801-2877
Tel 417 865-8715 800 825-6937 Fax 417 865-2950
<http://vacuum.tuthill.com>



Dimensions:

Dimensions are subject to change without notice.

Values shown are approximate and should not be used for construction.

Certified drawings are available through your local Tuthill Vacuum & Blower Systems Sales Professional

Bare Shaft Pump

Models: KLRC-40 & 75

PUMP ROTATION COUNTERCLOCKWISE

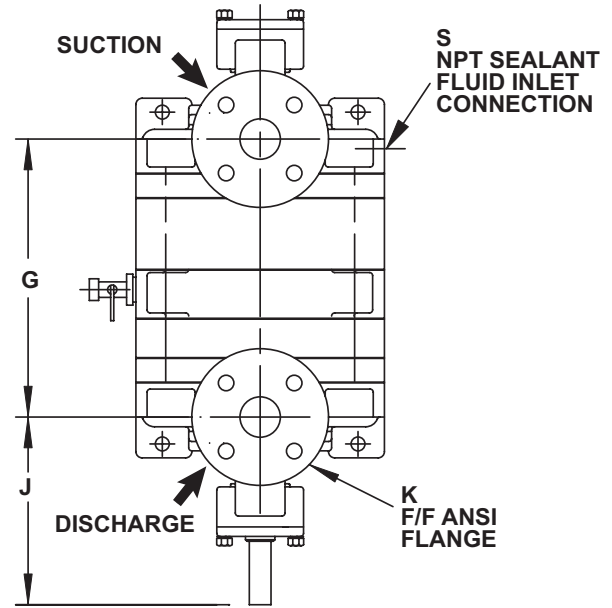
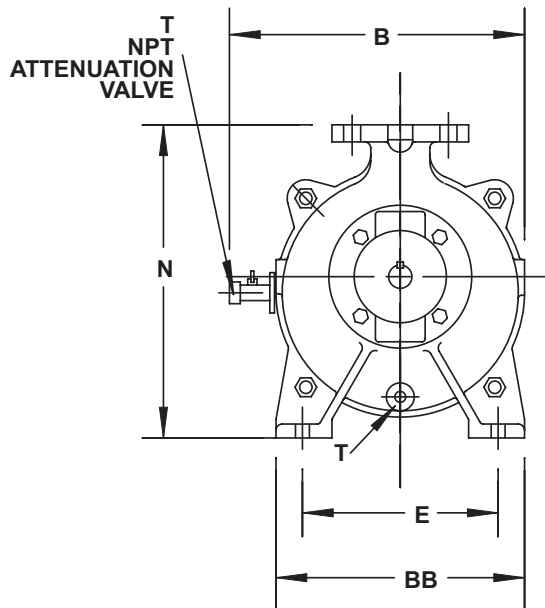
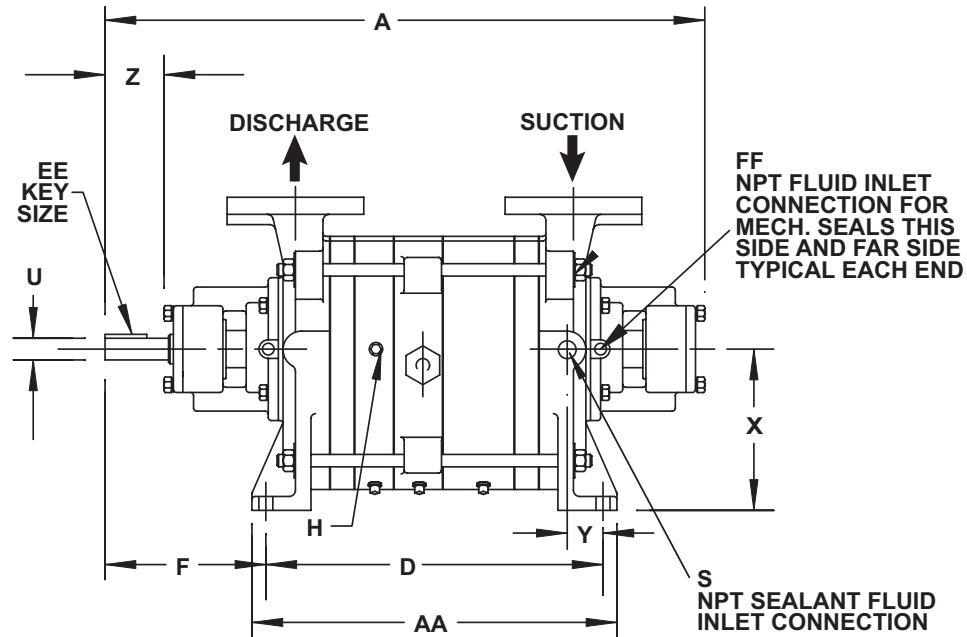

in mm	A	B	D	E	F	G	H	J	K	N
KLRC-40	22 9/16 573	11 7/8 301	12 304	7 7/8 200	6 3/8 162	9 5/8 244	1/4 NPTF	7 9/16 192	1 1/2"	12 5/8 320
KLRC-75	24 1/8 612	11 7/8 301	13 9/16 344	7 7/8 200	6 3/8 162	11 3/16 284	1/4 NPTF	7 9/16 192	1 1/2"	12 5/8 320

in mm	S	T	U	X	Y	Z	AA	BB	EE	FF	APPROX. WEIGHT LBS. / KG
KLRC-40	1/2" NPTF	1/4" NPTF	7/8"	6 1/2 165	1 7/16 36	2 3/8 60	13 1/8 333	10 254	3/16	1/8" NPTF	155 / 70
KLRC-75	1/2" NPTF	1/4" NPTF	7/8"	6 1/2 165	1 7/16 36	2 3/8 60	14 11/16 373	10 254	3/16 x 3/16	1/8" NPTF	200 / 91

Dimensions:

Dimensions are subject to change without notice.
 Values shown are approximate and should not be used for construction.
 Certified drawings are available through your local Tuthill Vacuum & Blower Systems Sales Professional

NSR (No Sealant Recovery) & PSR (Partial Sealant Recovery) System

Models: KLRC-40 & 75

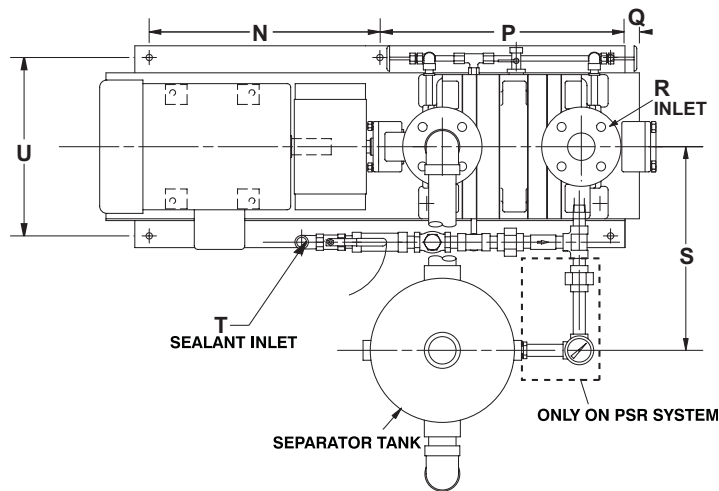
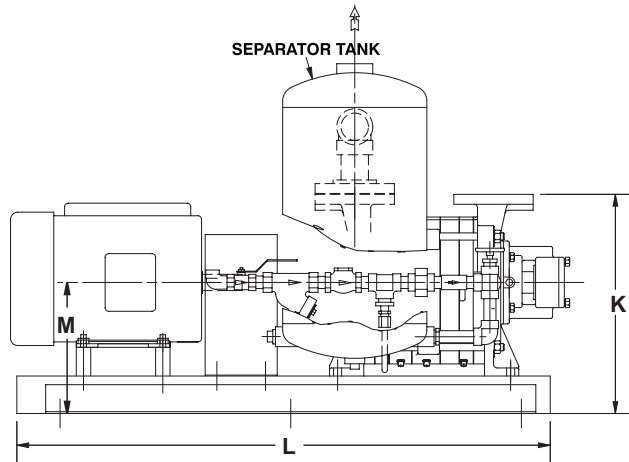
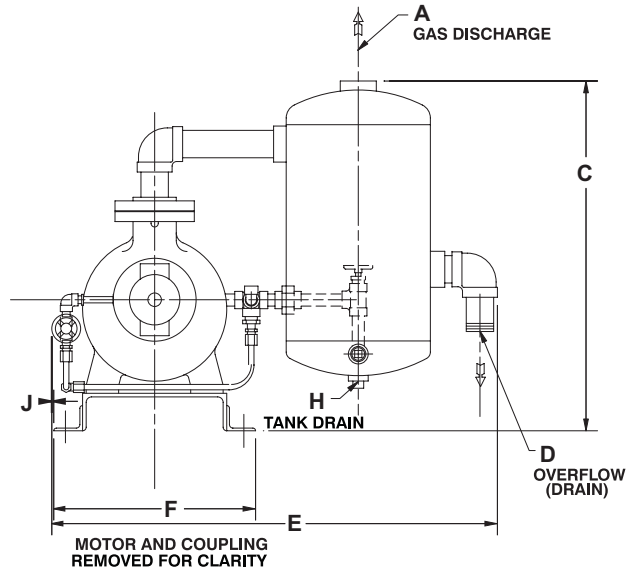

in mm	A	C	D	E	F	J	K	L	M	N	P	Q	R	S	T	U	APPROX. WEIGHT LBS. / KG
KLRC-40	1 1/2" NPTM	24 1/4 616	1 1/2" NPTM	30 15/16 786	14 356	1/8 3	15 3/16 386	37 940	9 1/16 230	16 406	16 406	2 51	1 1/2" F/F Flange	14 1/8 359	1/2" NPTF	12 3/8 314	467 212
KLRC-75	1 1/2" NPTM	24 1/4 616	1 1/2" NPTM	30 15/16 786	14 356	1/8 3	15 3/16 386	37 940	9 1/16 230	16 406	16 406	2 51		14 1/8 359	1/2" NPTF	12 3/8 314	562 255

Dimensions:

Dimensions are subject to change without notice.
 Values shown are approximate and should not be used for construction.
 Certified drawings are available through your local Tuthill Vacuum & Blower Systems Sales Professional

FSR (Full Sealant Recovery) System

Models: KLRC-40 & 75

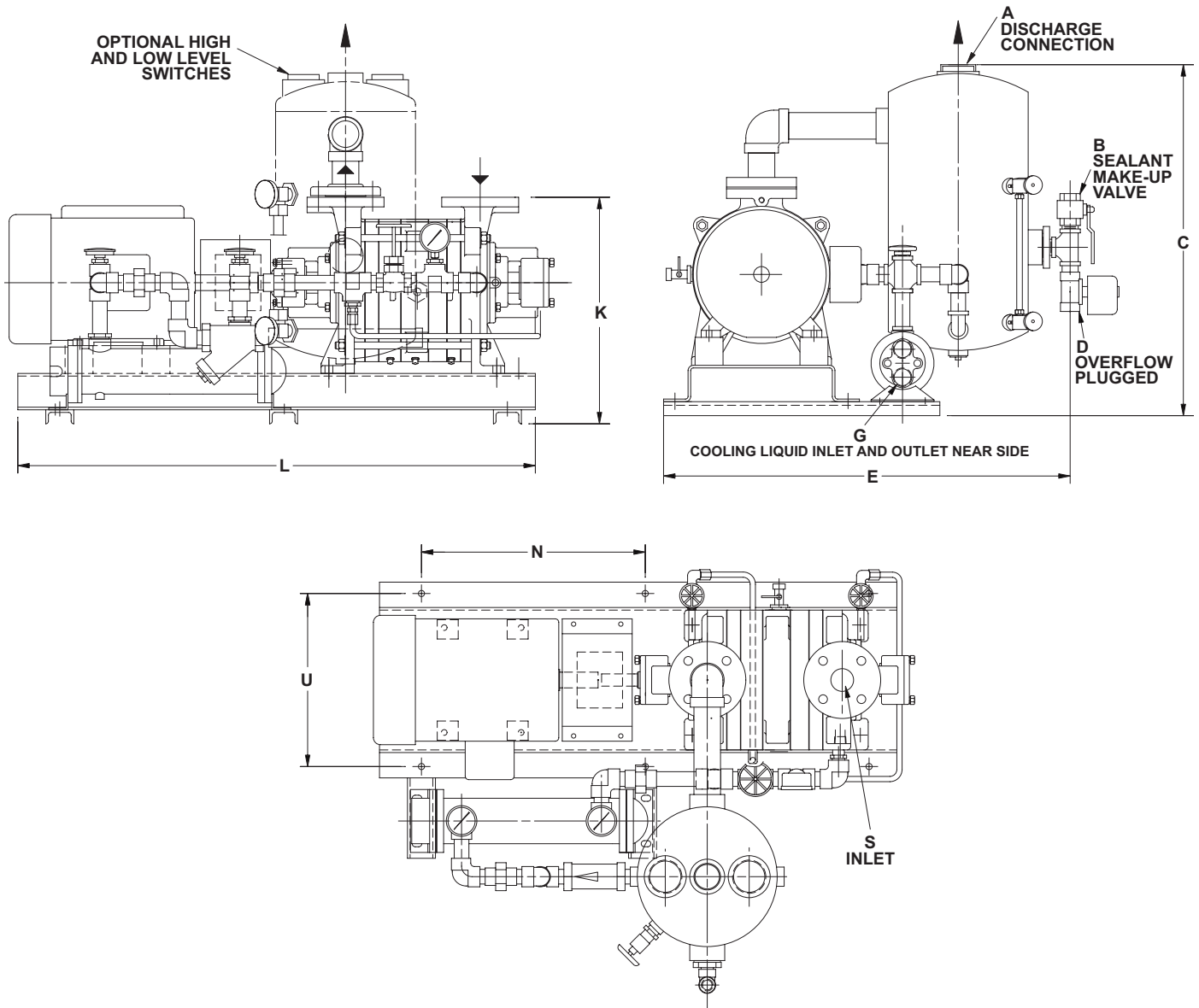

in mm	A	B	C	D	E	G	K	L	N	S	U	APPROX. WEIGHT LBS. / KG
KLRC-40	1 1/2" NPT	1/2" NPT	25 1/8 637	1/2" NPT	29 1/16 738	1" NPT	16 3/16 411	37 940	16 406	1 1/2" F/F Flange	12 3/8 314	483 219
KLRC-75	1 1/2" NPT	1/2" NPT	25 1/8 637	1/2" NPT	29 1/16 738	1" NPT	16 3/16 411	37 940	16 406		12 3/8 314	587 266

Your Local Tuthill Vacuum & Blower Systems Sales Professional:

LEADING THE SEARCH FOR NEW SOLUTIONS

TUTHILL
Vacuum & Blower Systems

4840 West Kearney Street, P. O. Box 2877
 Springfield, Missouri USA 65801-2877
 Tel 417 865-8715 800 825-6937 Fax 417 865-2950
<http://vacuum.tuthill.com>