

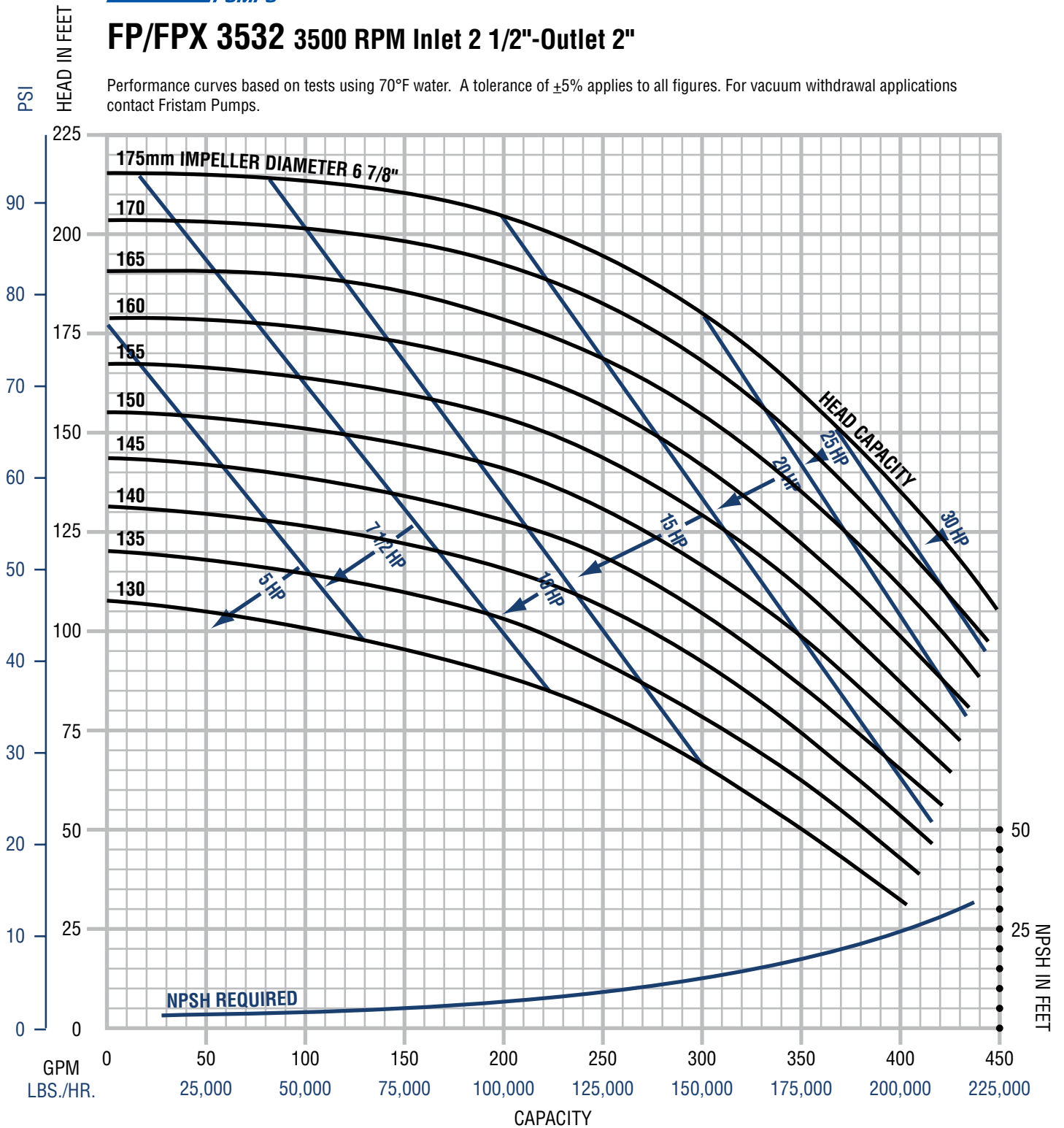

## FP/FPX 3532 3500 RPM Inlet 2 1/2"-Outlet 2"

Performance curves based on tests using 70°F water. A tolerance of  $\pm 5\%$  applies to all figures. For vacuum withdrawal applications contact Fristam Pumps.



# FPX Double Flange Dimensions

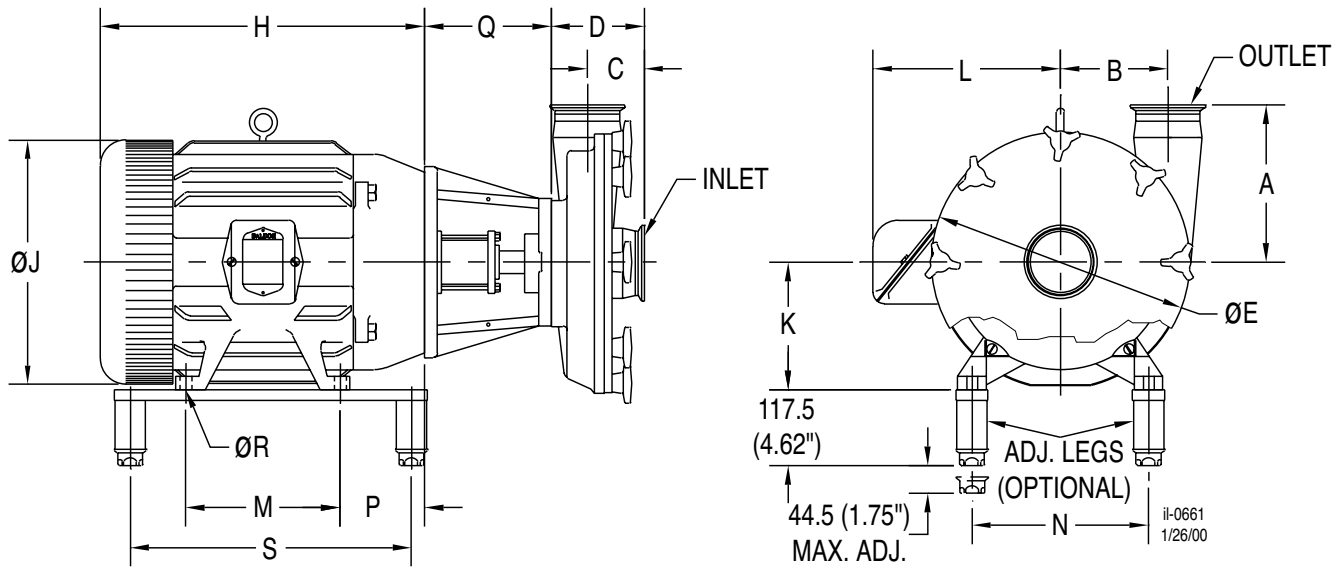

- NOTE:
- (1) Motor dimensions may vary depending on manufacturer requested.
  - (2) Pump dimensions are based on clamp fittings.
  - (3) All dimensions are in Millimeters (Inches).

PUMP MODEL	INLET	OUTLET	DIMENSIONS IN MILLIMETERS (INCHES)						MOTOR HP		MOTOR FRAME	DIMENSIONS IN MILLIMETERS (INCHES)									
			A	B	C	D	ØE	1750 RPM	3500 RPM	H		ØJ	K	L	M	N	P	Q	ØR	S	
FPX 1051	4"	4"	250 (9.84")	170 (6.69")	167 (6.57")	202.5 (7.97")	406 (15.98")		7.5 HP*	213TC	388 (15.27")	263 (10.34")	133 (5.25")	189 (7.46")	140 (5.50")	216 (8.50")	108 (4.25")	200 (7.87")	10.3 (13/32")	470 (18.50")	
FPX 1151	4"	4"	250 (9.84")	170 (6.69")	110.5 (4.35")	146 (5.75")	406 (15.98")		10 HP*	215TC	416 (16.40")	263 (10.34")	133 (5.25")	189 (7.46")	178 (7.00")	216 (8.50")	108 (4.25")	200 (7.87")	10.3 (13/32")	470 (18.50")	
FPX 1161	4"	4"	250 (9.84")	170 (6.69")	110.5 (4.35")	146 (5.75")	406 (15.98")		15 HP*	254TC	447 (17.59")	270 (10.62")	159 (6.25")	226 (8.88")	210 (8.25")	254 (10.00")	121 (4.75")	200 (7.87")	13.5 (17/32")	444 (17.50")	
FPX 1161	6"	4"	250 (9.84")	170 (6.69")	111 (4.37")	146 (5.75")	406 (15.98")		20 HP*	256TC	499 (19.66")	320 (12.60")	159 (6.25")	239 (9.42")	254 (10.00")	254 (10.00")	121 (4.75")	200 (7.87")	13.5 (17/32")	470 (18.50")	
FPX 1742	2.5"	2"	200 (7.87")	91 (3.58")	104 (4.09")	153 (6.02")	270 (10.63")		25 HP	284TC	588 (23.13")	367 (14.44")	178 (7.00")	333 (13.11")	241 (9.50")	279 (11.00")	121 (4.75")	200 (7.87")	13.5 (17/32")	444 (17.50")	
FPX 3532	2.5"	2"	191 (7.52")	95 (3.74")	115.5 (4.55")	164.5 (6.48")	260 (10.24")		25 HP	284TSC	588 (23.13")	367 (14.44")	178 (7.00")	333 (13.11")	241 (9.50")	279 (11.00")	121 (4.75")	200 (7.87")	13.5 (17/32")	444 (17.50")	
FPX 3542	3"	2.5"	211 (8.31")	115 (4.53")	118 (4.64")	164.5 (6.48")	290 (11.42")		30 HP	286TC	588 (23.13")	367 (14.44")	178 (7.00")	333 (13.11")	279 (11.00")	279 (11.00")	121 (4.75")	200 (7.87")	13.5 (17/32")	444 (17.50")	
FPX 3452	3"	2"	211 (8.31")	140 (5.51")	114 (4.49")	160.5 (6.32")	350 (13.78")		30 HP	286TSC	588 (23.13")	367 (14.44")	178 (7.00")	333 (13.11")	279 (11.00")	279 (11.00")	121 (4.75")	200 (7.87")	13.5 (17/32")	444 (17.50")	
FPX 3552	3"	2.5"	231 (9.09")	140 (5.51")	119 (4.68")	170.5 (6.71")	350 (13.78")		40 HP	324TC	636 (25.00")	413 (16.25")	203 (8.00")	371 (14.62")	267 (10.50")	318 (12.50")	133 (5.25")	216 (8.50")	16.7 (21/32")	470 (18.50")	
									40 HP	324TSC	636 (25.00")	413 (16.25")	203 (8.00")	371 (14.62")	267 (10.50")	318 (12.50")	133 (5.25")	216 (8.50")	16.7 (21/32")	470 (18.50")	
									50 HP	326TC	636 (25.00")	413 (16.25")	203 (8.00")	371 (14.62")	305 (12.00")	318 (12.50")	133 (5.25")	216 (8.50")	16.7 (21/32")	470 (18.50")	
									50 HP	326TSC	636 (25.00")	413 (16.25")	203 (8.00")	371 (14.62")	305 (12.00")	318 (12.50")	133 (5.25")	216 (8.50")	16.7 (21/32")	470 (18.50")	

\*1051, 1151, 1161 ONLY

il-0660  
01/26/00