

Construction Details CXV Models

Evaporative Condensers

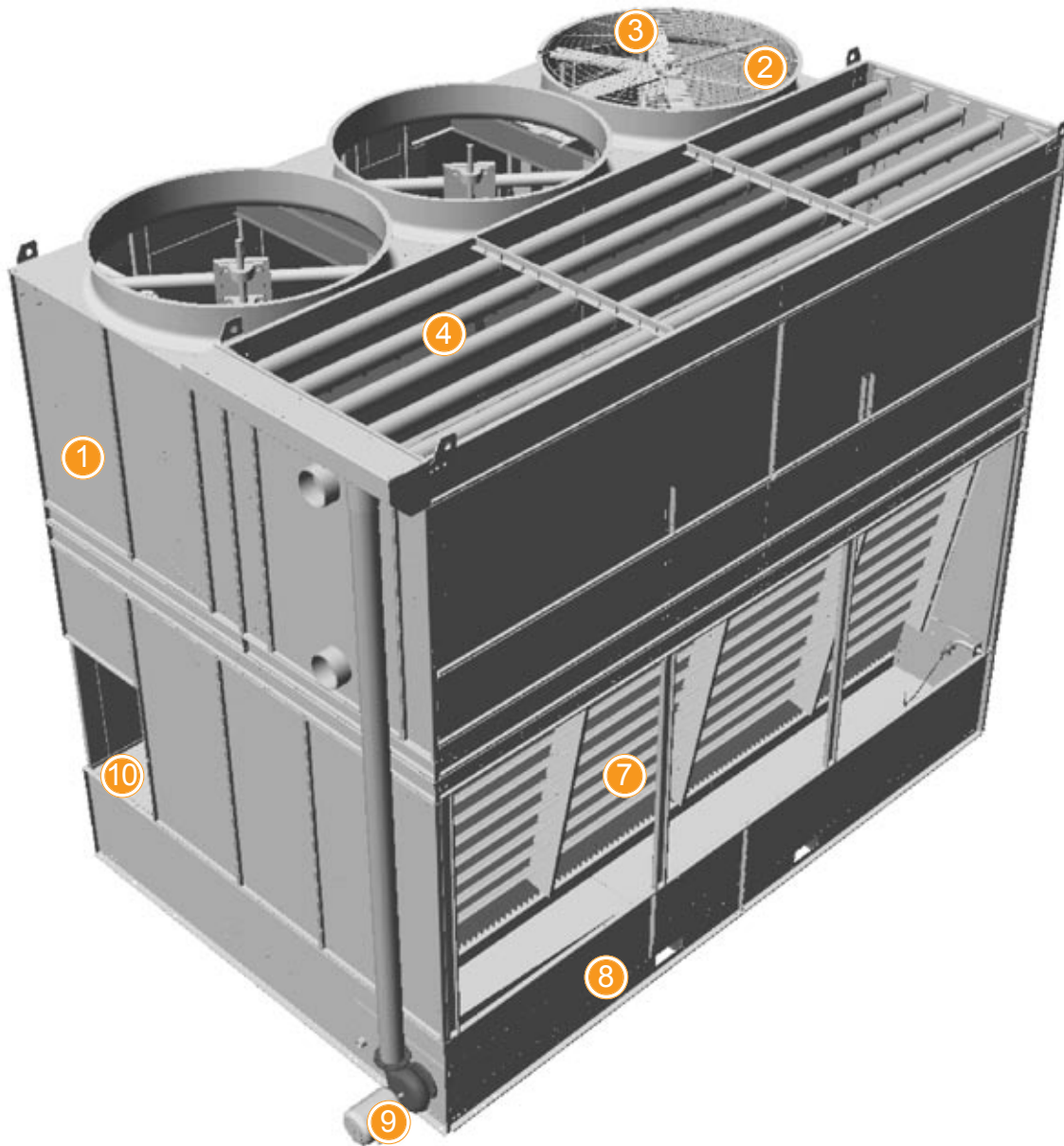



1 Heavy-Duty Construction

- G-235 (Z700 metric) hot-dip galvanized steel panels

2 BALTIDRIVE® Power Train

- Premium quality, solid-backed, multi-groove belt
- Corrosion resistant cast aluminum sheaves
- Heavy-duty bearings (280,000 hour average life)
- Cooling tower duty fan motor
- 5-year motor and drive warranty



3 Low HP Axial Fan(s)

- Quiet operation
- Corrosion resistant

4 Water Distribution System

- Visible and accessible during operation
- Overlapping spray patterns ensure proper water coverage
- Large orifice, 360° non-clog nozzles

5 Coil Section (Not Shown)

- Continuous serpentine, steel tubing
- Hot-dip galvanized after fabrication (HDGAF)
- Pneumatically tested at 375 psig
- Sloped tubes for free drainage of fluid
- ASME B31.5 compliant
- Orders shipping into Canada are supplied with a CRN

6 BACross® Fill with Integral Drift Eliminators (Not Shown)

- Polyvinyl chloride (PVC)
- Impervious to rot, decay and biological attack
- Flame spread rating of 5 per ASTM E84-77a

7 FRP Air Inlet Louvers

- Corrosion resistant
- UV resistant finish
- Maintenance free

8 Cold Water Basin

- Sloped cold water basin for easy cleaning
- Suction strainer with anti-vortex hood accessible from louver face
- Adjustable water make-up assembly accessible from louver face
- Integral internal walkway

9 Recirculating Spray Water Pump

- Close coupled, bronze fitted centrifugal pump
- Totally enclosed fan cooled (TEFC) motor
- Bleed line with metering valve installed from pump discharge to overflow

10 Hinged Access Doors

- Inward swinging door on each end wall

Models CXV-196 to 481

Do not use for construction. Refer to factory certified dimensions. This handbook includes data current at the time of publication, which should be reconfirmed at the time of purchase. Up-to-date engineering data, free product selection software and more can be found at www.BaltimoreAircoil.com.

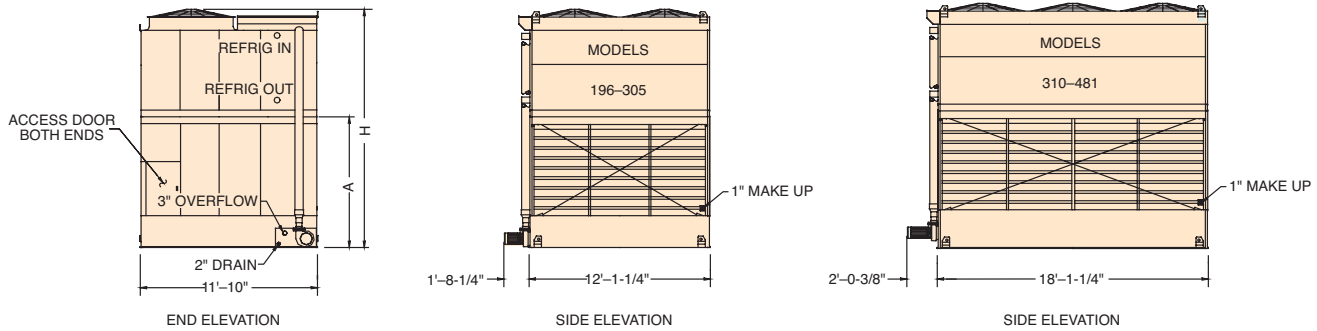

Refrigeration

Nom. Box Size	Model Number ¹	Base Heat Rejection (MBH)	R-22 Tons ²	Fan Motor (HP)	Airflow Rate (CFM)	Pump Motor (HP)	Approx. Weights (lbs)			Ammonia Operating Charge (lbs) ⁵	Internal Coil Volume (ft ³)	Spray Flowrate (GPM)	Remote Sump			A	H
							Ship.	Heaviest Section	Oper. ³				Drain Size (in)	Volume Required (gal)	Approx. Oper. Wt. (lbs)		
12' x 12'	CXV-196	4,062	248	10	68,160	5	10,740	6,580	17,480	164	20	715	10	600	16,920	8'-8 3/4"	15'-10 3/4"
	CXV-210	4,353	266	15	77,900	5	10,790	6,630	17,530	164	20	715	10	600	16,970	8'-8 3/4"	15'-10 3/4"
	CXV-220	4,560	278	20	85,650	5	10,840	6,680	17,580	164	20	715	10	600	17,020	8'-8 3/4"	15'-10 3/4"
	CXV-235	4,871	297	10	67,200	5	11,780	7,620	18,670	217	26	715	10	600	18,110	8'-8 3/4"	15'-10 3/4"
	CXV-253	5,244	320	15	76,800	5	11,830	7,670	18,720	217	26	715	10	600	18,160	8'-8 3/4"	15'-10 3/4"
	CXV-264	5,472	334	10	64,930	5	12,830	8,670	19,870	270	32	715	10	600	19,310	8'-8 3/4"	15'-10 3/4"
	CXV-283	5,866	358	15	74,200	5	12,880	8,720	19,920	270	32	715	10	600	19,360	8'-8 3/4"	15'-10 3/4"
	CXV-290	6,011	367	15	72,700	5	13,920	9,760	21,110	321	38	715	10	600	20,550	8'-8 3/4"	15'-10 3/4"
	CXV-305	6,322	386	20	79,950	5	13,970	9,810	21,160	321	38	715	10	600	20,600	8'-8 3/4"	15'-10 3/4"
12' x 18'	CXV-310	6,425	392	15/7.5	117,900	7.5	15,320	9,500	25,500	243	29	900	10	750	24,940	9'-2 1/4"	16'-4 1/4"
	CXV-324	6,716	410	10/5	129,650	7.5	15,410	9,590	25,590	243	29	900	10	750	25,030	9'-2 1/4"	16'-4 1/4"
	CXV-337	6,985	427	25/15	139,550	7.5	15,510	9,690	25,690	243	29	900	10	750	25,130	9'-2 1/4"	16'-4 1/4"
	CXV-349	7,234	442	10/5	101,760	7.5	16,810	10,990	27,210	321	39	900	10	750	26,650	9'-2 1/4"	16'-4 1/4"
	CXV-373	7,731	472	15/7.5	116,300	7.5	16,890	11,070	27,290	321	39	900	10	750	26,730	9'-2 1/4"	16'-4 1/4"
	CXV-388	8,042	491	10/5	98,310	7.5	18,400	12,580	29,030	401	48	900	10	750	28,470	9'-2 1/4"	16'-4 1/4"
	CXV-398	8,249	504	10/5	96,290	7.5	19,990	14,170	30,830	475	57	900	10	750	30,270	9'-2 1/4"	16'-4 1/4"
	CXV-416	8,622	527	15/7.5	112,350	7.5	18,480	12,660	29,110	401	48	900	10	750	28,550	9'-2 1/4"	16'-4 1/4"
	CXV-427	8,850	541	15/7.5	110,050	7.5	20,070	14,250	30,910	475	57	900	10	750	30,350	9'-2 1/4"	16'-4 1/4"
	CXV-449	9,306	568	20/10	121,050	7.5	20,150	14,330	30,990	475	57	900	10	750	30,430	9'-2 1/4"	16'-4 1/4"
	CXV-466	9,659	590	25/15	130,300	7.5	20,260	14,440	31,100	475	57	900	10	750	30,540	9'-2 1/4"	16'-4 1/4"
	CXV-481	9,970	609	30/15	138,350	7.5	20,280	14,460	31,120	475	57	900	10	750	30,560	9'-2 1/4"	16'-4 1/4"

Notes:

- Model number denotes nominal ammonia capacity in evaporator tons at a 96.3°F condensing temperature, a 20°F suction temperature, and a 78°F wet-bulb temperature.
- R-22 tons are at a 105°F condensing temperature, a 40°F suction temperature, and a 78°F wet-bulb temperature.
- Operating weight is for the unit with the water level in the cold water basin at the overflow.
- For R-22 and R-134a, the coil connection quantity will double (except for the CXV-64 thru -153).
- The R-22 operating charge is 1.93 times the ammonia charge; R-134a is 1.98 times.
- Inlet and outlet connections are beveled for welding.
- Standard make-up, drain and overflow connections are MPT.

...because temperature matters™



DIMENSION H	
FAN OPTION	H
STD FAN & LOW SOUND FAN	15'-10 3/4"
WHISPER QUIET FAN	16'- 4 1/4"

MODEL NUMBER	SHIPPING WEIGHT	OPERATING WEIGHT	HEAVIEST SECTION (UPPER)	CONNECTION SIZE	F
CXV-196	10,740	17,480	6580	4"	24"
CXV-210	10,790	17,530	6630	4"	24"
CXV-220	10,840	17,580	6680	4"	24"
CXV-235	11,780	18,670	7620	4"	33 1/4"
CXV-253	11,830	18,720	7670	4"	33 1/4"
CXV-264	12,830	19,870	8670	4"	42 1/2"
CXV-283	12,880	19,920	8720	4"	42 1/2"
CXV-290	13,920	21,110	9760	4"	51 3/4"
CXV-305	13,970	21,160	9810	4"	51 3/4"

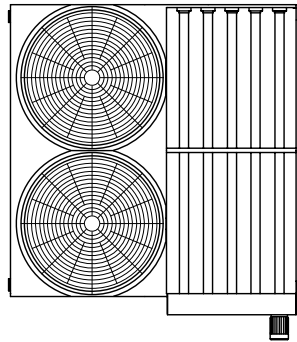

PLAN VIEW

NOTES:

1. ALL DIMENSIONS ARE IN FEET AND INCHES. WEIGHTS ARE IN POUNDS.
2. DIMENSIONS SHOWING LOCATION OF COIL CONNECTIONS ARE APPROXIMATE AND SHOULD NOT BE USED FOR PREFABRICATION OF CONNECTING PIPING.
3. COIL CONNECTIONS ARE IPS BEVELLED FOR WELDING.
4. CONNECTIONS 3" & SMALLER ARE MPT.
5. THE AREA ABOVE THE DISCHARGE OF THE FAN MUST BE UNOBSTRUCTED.
6. FOR WEIGHT LOADING AND SUPPORT REQUIREMENTS REFER TO THE SUGGESTED STEEL SUPPORT DRAWING.

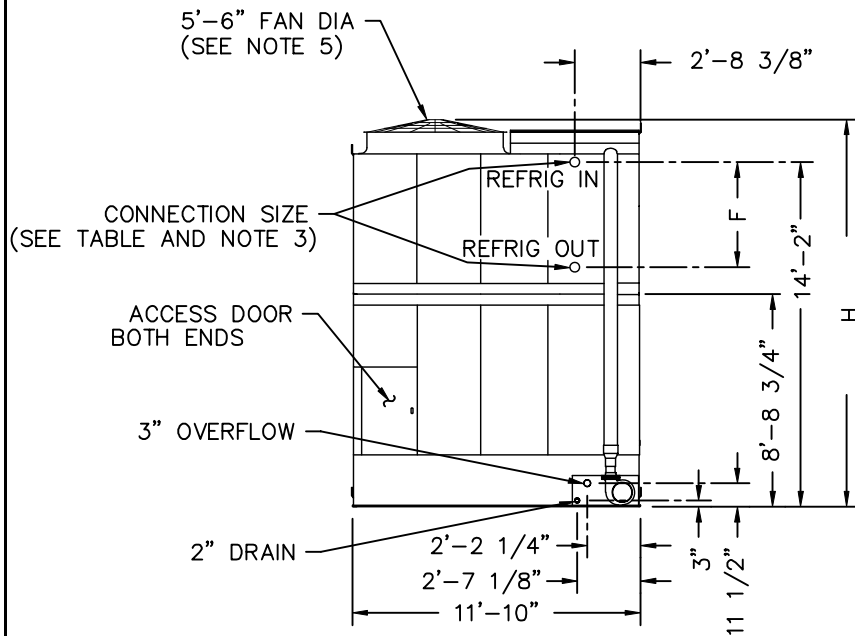

END ELEVATION

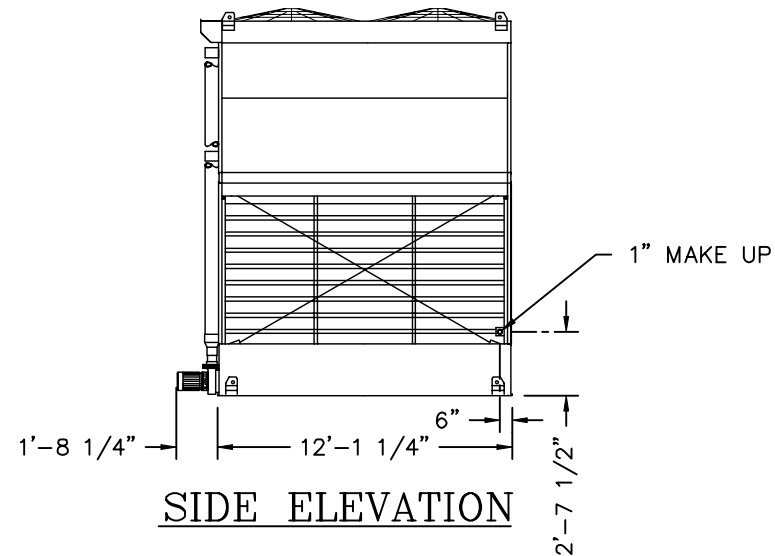

SIDE ELEVATION

(RH UNIT)

B.A.C.
ORDER NO:



BALTIMORE AIRCOIL
COMPANY

SERIES 1500
EVAPORATIVE CONDENSER

DATE:

DRAWING NUMBER:
BAC-17004A

C