

Skinning Machine BAADER 47

1. Technical specifications

Application:	Skinning of fillets cut from white fish, red fish and flat fish.
Size range:	Largest fillet: 22 cm
Output:	abt. 60 fillets / min., depending on fillet length
Power consumption:	1,1 kW
Dimensions of the machine:	
Length:	2100 mm
Width:	800 mm
Height:	1070 mm

Design for ashore installation

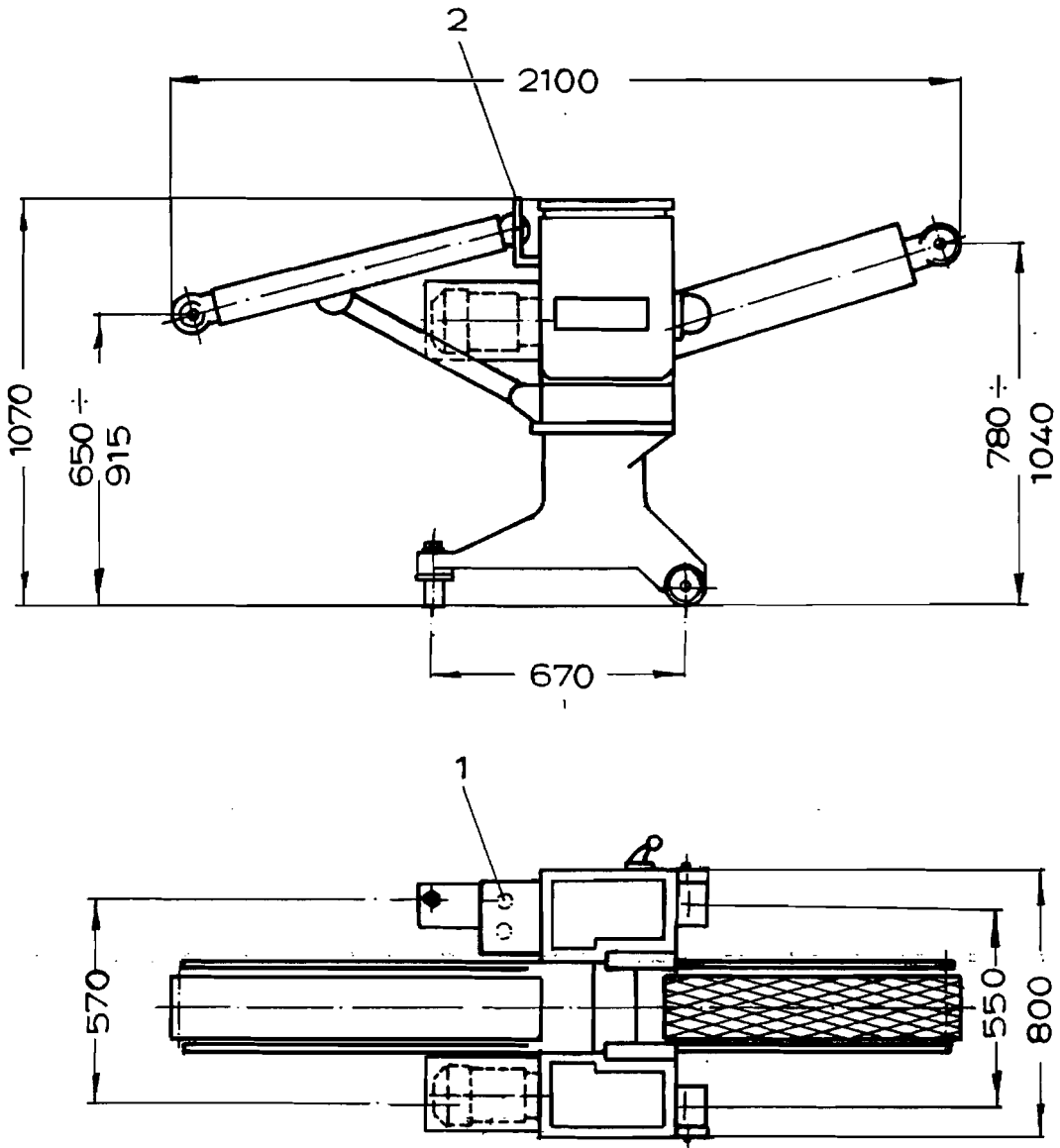

- 1. Power connection
- 2. Water connection

Design for onboard installation

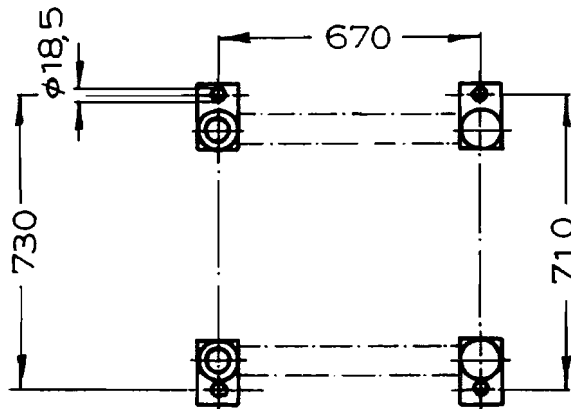
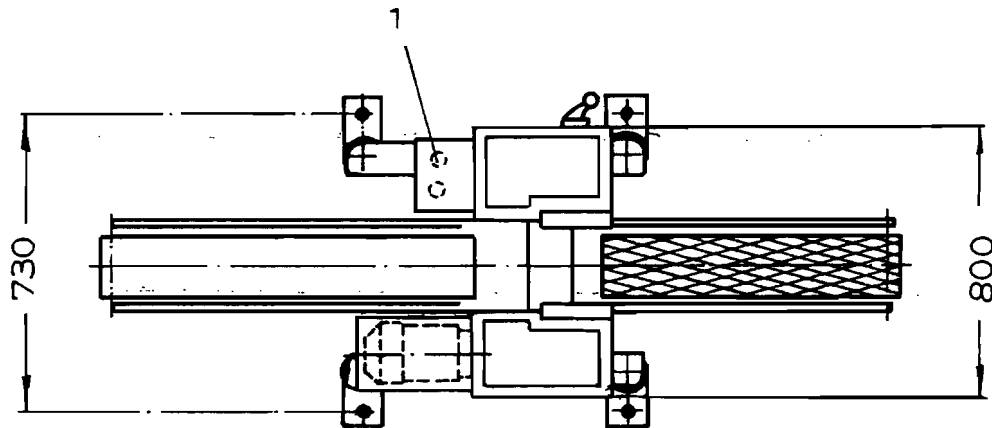
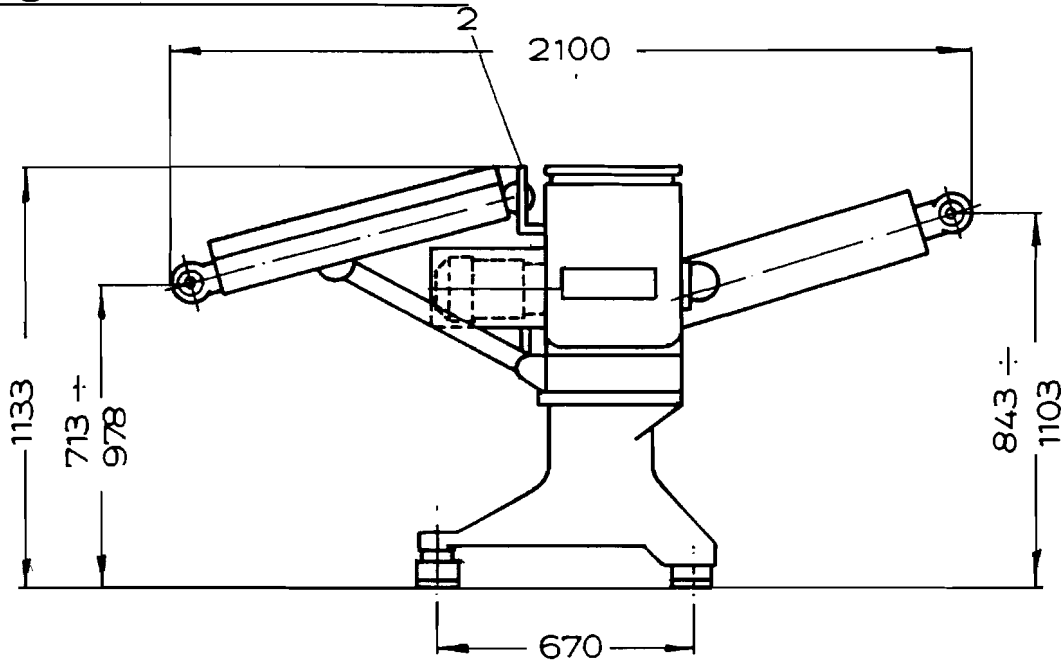

- 1. Power connection .
- 2. Water connection