



Item A - 100 CUBIC FOOT CAPACITY BIN – VALUE LINE “INVERT-A-BIN “
VALUE LINE BINS

Value-Line Bin Finishes:

(Unless otherwise noted in the proposal)

External Finish: Body material is 2B sheet (10 Ra micro-inch or better) material finish sheet and structure is 2B/Mil finish. Welds are as laid; chemically treated to produce a high luster finish.

Internal Finish: 2B sheet (10 Ra micro-inch or better) material finish Welds are as laid; chemically treated to produce a high luster finish

Value-Line Material of Construction:

(Unless otherwise noted in the proposal)

Product contact surfaces - 304 stainless steel

Non-Product contact surfaces - 304 stainless steel

Gaskets – EPDM

Body Thickness: 12 gauge

Weld Procedure: All welds crafted by TIG/MIG weld equipment and methods

Hopper Angle: 45° from horizontal

Volumetric Cap: 100 Cubic Foot waterfill capacity. Actual working capacity will be somewhat less dependent on angle of repose, product aeration and process conditions. Blend volume would be 60 cubic feet.

Top Design: Invert-A-bin Cone top with 22" nominal diameter lid with quick acting lever type clamp band and EPDM gasket. .

Base: Flat 10 Ga bottom with 4 ½" legs

Base Dim's: Nominal 42" x 48"

Stacking: Stacking guides on top four corners of bin allow stacking two high and serve as clamping fixtures for use in tumble blender.



ITEM B - TOTE® INTERMEDIATE CONE DISCHARGE

Base Dim's:	Direct Mount to the outlet hopper of the bins with a lever locking clamp ring.
Material of Construction:	304 Stainless steel
Material Finish:	Product contact or discharge hopper and transition. Internal hopper is 2B material finish with welds ground to 150/180 grit or #4 finish
Hopper Seal:	Hopper designed with 12" compression seal for mating with TOTE® bin butterfly valve for a dust tight seal
Valve Actuation:	Manual bin valve actuator for opening and closing of butterfly valve on bin when placed in the discharge position.
Outlet Valve:	8" Sureseal butterfly valve with polished disc and food grade seat.

ITEM C - INVERTER FOR USE WITH INVERT-A-BIN

Material:	Carbon steel construction. Drives, bearings, etc. are manufacturers standard. Pedestal base is primed and painted FDA white paint.
General Design:	the bin Inverter. Mounted via forktruck.
Capacity:	5000 lb. capacity (bin plus product) designed to accommodate the TOTE® Bins quoted.
Discharge Height:	Designed to discharge into floor hopper at 28" overall height.
Controls:	Manual controls with start, stop and E-stop..
Electrical Panels:	One (1) electrical panel is shipped loose for field installation
Drives:	Direct drive motor/reducer unit - Motor is direct coupled to reducer.
Utility Req'd:	480 VAC/60 Hz/3 Phase @ 30 amps electrical. Control voltage is 24 VDC and is supplied by internal control power transformer 80 PSI compressed air (intermittent) @ 40 SCFM consumption

NOTES:

- I. QUALITY: INDUSTRIAL
- II. INVERTER OPERATES W/BIN 318669 ONLY
(5,000 lb MAX PRODUCT CAPACITY)
(5,750 lb MAX TOTAL CAPACITY)
- III. MATERIALS: CARBON STEEL
- IV. FINISHING:
 - A. ALL BURRS AND SHARP EDGES REMOVED
 - B. ALL WELDS CONTINUOUS, AS LAID, MECHANICALLY CLEANED
 - C. ALL SURFACES FREE OF PITS, CRACKS OR CREVICES (BY VISUAL INSPECTION ONLY)
- V. GENERAL:
 - A. 1 HP BRAKE MOTOR
 - B. 3 PHASE, 60 CYCLE, 208 VAC
 - C. PRIME & PAINT FIXED PARTS TOTE BLUE ENAMEL
 - D. PRIME & PAINT MOVING PARTS YELLOW ENAMEL
 - E. OPERATOR CONTROL PANEL WILL BE MOUNTED BY CUSTOMER REMOTELY IN A SAFE AREA
 - F. ROTATING SPEED = 0.7 RPM (APPROX 20 SECONDS TO INVERT)
- VI. OPERATOR CONTROLS TO INCLUDE:
 - A. 3 POSITION SWITCH MOMENTARY W/ CENTER OFF
- VII. CUSTOMER SUPPLIED REQUIREMENTS:
 - A. 208 VAC, 20 AMP, 3 PHASE
 - B. 120 VAC, 1 AMP, 1 PHASE
 - C. INSTALLATION
 - D. GUARD TO RESTRICT ACCESS DURING OPERATION

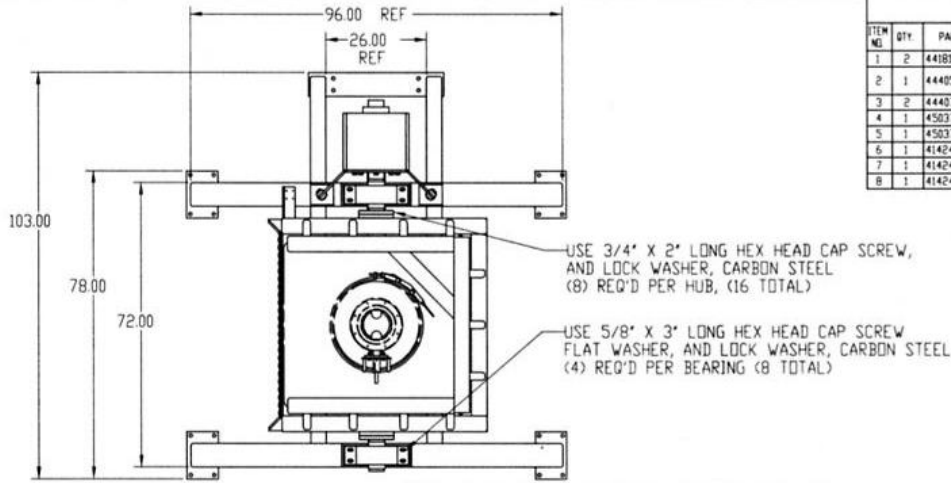

BILL OF MATERIAL				
ITEM NO.	QTY	PART NUMBER	MATERIAL	DESCRIPTION
1	2	441816	PURCH	BEARING-PILLOW BLOCK, DODGE, 042024, SAF-X1-4 BOLT BASE-3 15/16 BORE
2	1	444059	PURCH	GEARMOTOR, SUMITOMO, LHYM-DH-2E17DA-Y-1A-B-25591, 208 VAC, 3 15/16 BUSHING BORE
3	2	444072	PURCH	SENSOR-PROXIMITY SWITCH, PEPPERL+FUCHS, NJ15-U1-W4
4	1	450373-10	NOTED	INVERTER SHAFT WELDMENT, 10 LONG
5	1	450373-30	NOTED	INVERTER SHAFT WELDMENT, 10 LONG
6	1	414241A1	NOTED	BASE FRAME WELDMENT
7	1	414241A2	NOTED	CRABLE ASSEMBLY
8	1	414241A4	NOTED	TORQUE ARM ASSY

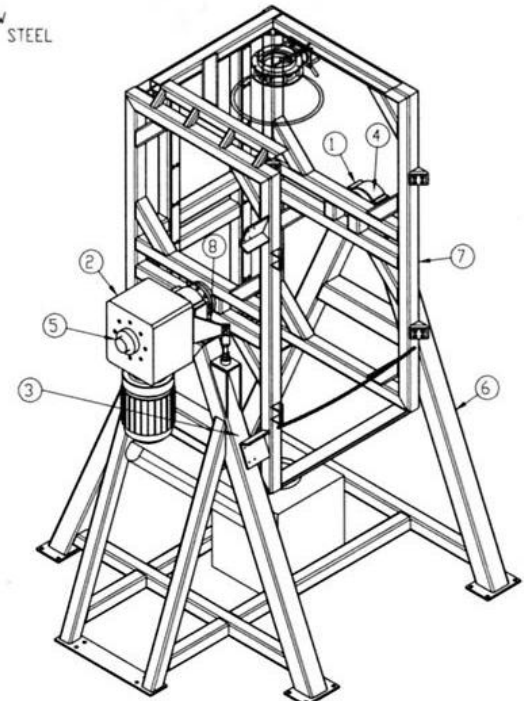
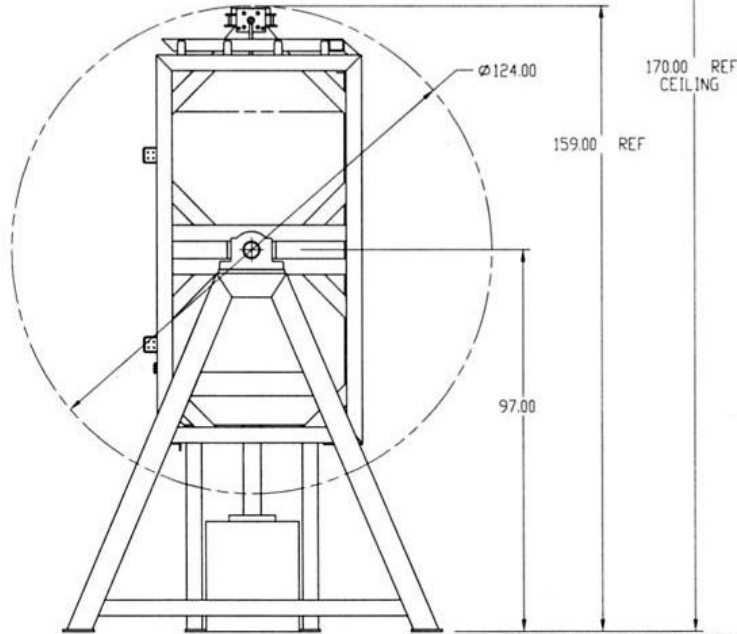
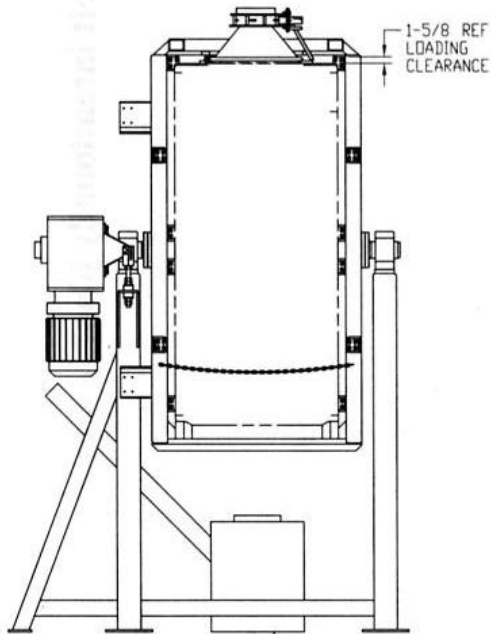

C	CB	12-10-04	ADDED BALLBOOLS
B	JBP	12/3/04	REVISED FOR MANUFACTURING DRAWINGS
A	JBP	11/12/04	APPROVAL DRAWING REVISION
REV. BY	DATE	DESCRIPTION	
JBP	12/25/04	180" INVERTER	
Checked By	App'd By	Customer	GLOBAL FOODS 4001 TAFT AVENUE ST. LOUIS, MO 63116
Drawn Date	App'd Date	P. O. No.	4093
10/25/04	1/32	Job No.	4-60053
Scale	Size	Equipment	INVERTER
1/32	B	Drawing No.	414241

THIS DOCUMENT REMAINS PROPERTY OF TOTE SYSTEMS INTERNATIONAL AND IS SUBJECT TO RETURN UPON DEMAND. NET TO BE COPIED OR REPRODUCED IN ANY FORM WITHOUT WRITTEN CONSENT.



424 NORTH BARKLEY BLVD
BARKLEY, TX 75828
(937) 447-3000