

# **MaximICE®**

## **LIQUID ICE TES SYSTEM ORE-25, 50, & 100 OWNER'S MANUAL**



**PART NO. 9840502**

**EFFECTIVE SEPTEMBER 1, 1998**

**REVISED DECEMBER 1, 2000**

**MUELLER®**

THERMAL STORAGE PRODUCTS

**MaximICE<sup>®</sup> LIQUID ICE TES SYSTEM  
ORE-25, 50, & 100 OWNER'S MANUAL****TABLE OF CONTENTS****Section 1.0 - Introduction**

1.0	Introduction	1
1.1	Delivery Inspection	1
1.2	Safety Considerations	1

**Section 2.0 - Thermal Storage System - System Overview**

2.0	Thermal Storage System - System Overview	2
2.1	Refrigeration Circuit	2
2.2	Ice-Build Circuit	2
2.3	Building Cooling Circuit	3

**Section 3.0 - Installation**

3.0	Installation	4
3.1	Equipment Rigging	4
3.2	Foundation	4
3.3	Anchoring	4
	Figure 1—Anchorage Details	4
3.4	Serviceability	5
3.5	Shipping Charge	5
3.6	Remote Refrigeration Piping	5
3.7	Refrigerant Piping Pressure Test	5
3.8	System Evacuation	5
3.9	Refrigerant Charge	5
3.10	Condensing Unit	5
3.11	Electrical	6
3.12	Electrical Specifications: ORE-25	6
3.13	Electrical Specifications: ORE-50	6
3.14	Electrical Specifications: ORE-100	7
3.15	Ice Storage Tank - Full Ice Sensor Option	7
3.16	Ice Storage Tank - Vent Line	7
3.17	Ice Storage Tank - Spraying System	7
3.18	Glycol Solution Specification	7
3.19	Freeze Protection	9
3.20	Insulation	9
3.21	ORE Drive Assembly	9
	Figure 2—ORE Drive Assembly Detail	10
3.22	Gravity Feed System	10
	Figure 3—MaximICE ORE-25 Drive Assembly	11
	Figure 4—MaximICE ORE-50 Drive Assembly	12
	Figure 5—MaximICE ORE-100 Drive Assembly	13
	Figure 6—ORE Countercrank Assembly	14
3.23	Packing Material(s)	15
	Figure 7—MaximICE Refrigeration Schematic Diagram	15

## TABLE OF CONTENTS - CONTINUED

### Section 10.0 - Troubleshooting Failures

10.1	Low-Pressure Evaporator - Freeze-Up Protection Alarm	.33
10.2	Unit Fails on Vent Switch	.34
10.3	Unit Will Not Start	.35
10.4	Compressor Operates with High Discharge Pressure	.36
10.5	Compressor Operates with Low Suction Pressure	.37
10.6	System Will Not Make Ice	.38
10.7	Compressor Fails on Motor Overload	.39
10.8	System Will Not Cool Building/Process Load	.40
10.9	Excessive Evaporator Shell Vibration	.41
10.10	Compressor Fails on Low Oil Pressure	.42
10.11	Excessive Wear	.43

### Section 11.0 - Start-Up Requirements

11.1	MaximICE Start-Up Request Form	.44
11.2	MaximICE Evaporator Unit	.44
11.3	Refrigerant Piping for Remote Condenser Systems	.44
11.4	Water Piping	.45
11.5	Electrical	.45
11.6	Installing Contractor Shall Furnish the Following	.45
11.7	Compressor Package	.45

### Section 12.0 - Wiring Diagram

12.1	Schematic Wiring Diagram (50 hz), Part No. 9841026	.46
12.2	Schematic Wiring Diagram (60 hz), Part No. 9823978	.47

### Section 13.0 - Equipment Specifications

13.1	Model ORE-25, Flooded Refrigerant Feed, Pumped Slush Discharge, Drawing No. 8200139	.48
13.2	Model ORE-25, Flooded Refrigerant Feed, Pumped Slush Discharge Schematic, Drawing No. 8200146	.49
13.3	Model ORE-25, Flooded Refrigerant Feed, Gravity Slush Discharge, Drawing No. 8200153	.50
13.4	Model ORE-25, Flooded Refrigerant Feed, Gravity Slush Discharge Schematic, Drawing No. 8200160	.51
13.5	Model ORE-50, Flooded Refrigerant Feed, Pumped Slush Discharge, Drawing No. 8200140	.52
13.6	Model ORE-50, Flooded Refrigerant Feed, Pumped Slush Discharge Schematic, Drawing No. 8200147	.53
13.7	Model ORE-50, Flooded Refrigerant Feed, Gravity Slush Discharge, Drawing No. 8200154	.54
13.8	Model ORE-50, Flooded Refrigerant Feed, Gravity Slush Discharge Schematic, Drawing No. 8200161	.55
13.9	Model ORE-100, Flooded Refrigerant Feed, Pumped Slush Discharge, Drawing No. 8200141	.56
13.10	Model ORE-100, Flooded Refrigerant Feed, Pumped Slush Discharge Schematic, Drawing No. 8200148	.57
13.11	Model ORE-100, Flooded Refrigerant Feed, Gravity Slush Discharge, Drawing No. 8200155	.58
13.12	Model ORE-100, Flooded Refrigerant Feed, Gravity Slush Discharge Schematic, Drawing No. 8200162	.59

### Section 14.0 - Start-Up Request Form

### Section 15.0 Warranty

### Notes

## TABLE OF CONTENTS - CONTINUED

### Section 4.0 - Pre Start-Up/Installation Requirements

4.1	Evaporator Unit Drive	.16
4.2	Water Loop/Piping	.16
4.3	Electrical	.17
4.4	Refrigerant Piping	.17
4.5	Start-Up Coordination/Inspection	.17
4.6	Start-Up Policy	.17

### Section 5.0 - Start-Up/Refrigerant Charging

5.0	Start-Up/Refrigerant Charging	.18
-----	-------------------------------	-----

### Section 6.0 - Sequence Of Control

6.0	Sequence of Control	.19
6.1	Start-Up Sequence	.19
6.2	Shutdown Sequence	.19
6.3	Restart Sequence	.20
6.4	Alarm Condition Sequence	.20
6.5	Additional Control Elements	.20

### Section 7.0 - Safety

7.1	Label, Danger, "Unit Starts Up Automatically"	.21
7.2	Label, Electric Symbol, Part No. 8820623	.21
7.3	Label, Danger, "High Voltage"	.21
7.4	Label, Caution, "Do Not Run Dry," Part No. 8850229	.22
7.5	Label, Caution, "If The Bearing Gap," Part No. 9842772	.22
7.6	Equipment dB Ratings	.22

### Section 8.0 - Maintenance

8.0	Maintenance	.23
8.1	Daily Checks	.23
8.2	Recommended Inspection Procedures	.23
	Figure 8—Drive Plate Inspection Criteria	.24
	Figure 9—Drive Plate Inspection Criteria	.25
	Figure 10—Counter crank Inspection Criteria	.26
	Figure 11—Whip Rod Inspection Criteria	.27
	Figure 12—Bearing Sleeve Inspection Criteria	.28
	Figure 13—Tube Insert Inspection Criteria	.29
	Figure 14—Eccentric Crank Inspection Criteria	.29
8.3	Recommended Drive Component(s) Replacement Schedule	.30
8.4	Recommended Monitoring Points	.30

### Section 9.0 - Recommended Spare Parts

9.0	Recommended Spare Parts	.31
9.1	ORE Common Parts	.31
9.2	ORE-25 Parts	.31
9.3	ORE-50 Parts	.31
9.4	ORE-100 Parts	.32

# SECTION 1.0 - INTRODUCTION

## 1.0 Introduction

The MaximICE® evaporator assembly is a thermal energy storage system intended for producing a large amount of ice slurry. The ice slurry is used to take advantage of off-peak electrical power usage (usually at night). The ice slurry is then used during the on-peak electrical usage periods for air-conditioning or process cooling. This in turn reduces the electrical demand usage and energy costs. Compared to traditional cooling systems, the MaximICE system utilizes smaller equipment, thus reducing capital cost.

The MaximICE should only be operated by trained personnel and serviced by qualified electrical and refrigeration technicians. Any use of the equipment not covered by the instructions is prohibited.

This manual has been prepared to present to the owner and service technician the installation, operation, and maintenance procedures recommended by Paul Mueller Company for the MaximICE thermal storage system. The installation plans, piping layouts, etc., must be detailed in accordance with local codes. If you are uncertain about any installation or operating procedure outlined in this manual, please contact the Mueller Thermal Storage Department for guidance at 1-800-683-5537 or (417) 831-3000.

## 1.1 Delivery Inspection

Each MaximICE evaporator is tested (operational or electrical test) at the factory prior to shipment; however, damage can occur during shipment. The unit should be thoroughly inspected upon arrival at the installation site. Any damage noted should be reported immediately to the transportation company so that an authorized transportation representative can examine the unit, determine the extent of the damage, and take the necessary steps to rectify the claim. At the same time, a Paul Mueller Company representative should be notified of any claim made.

## 1.2 Safety Considerations

Installation, start-up, and service of this equipment pose hazards due to automatic equipment operation, high system pressure, and electrical power service. It is extremely important to consider all aspects of safety when working on or around machinery and high voltage. This equipment will be connected to a high-voltage and/or current power supply which can seriously injure or kill a worker. There is moving equipment which can start automatically and cause serious injury. It is imperative that only qualified service personnel install and service this equipment.

**This equipment is designed for use with and contains R-22 hydrochlorofluorocarbon (HCFC), R-717 ammonia or other types of refrigerant. This equipment shall be serviced and disposed of in accordance with the current Ozone Depleting Substance Regulation - Clean Environment Act.**

When working on this equipment, observe precautions identified in the literature provided, any tags, stickers, and labels attached to the equipment, and any other safety precautions that apply.

- ▲ Follow all applicable safety codes.
- ▲ Wear safety glasses and work gloves.
- ▲ Use care in handling, rigging, and setting bulky equipment.

## SECTION 2.0 - THERMAL STORAGE SYSTEM - SYSTEM OVERVIEW

### 2.0 Thermal Storage System - System Overview

It is very important that each component be properly sized and selected. Extreme care must be taken if individual component(s) are selected and supplied by others. System performance and operation can be compromised if any part of the system is incorrectly sized.

The typical MaximICE system consists of three individual circuits: refrigeration circuit, ice building circuit, and cooling circuit. The working system includes an ice storage tank, plate-and-frame heat exchanger, coolant pump(s), temperature control valve, and piping. The following information describes each component of the system, along with its operational function.

### 2.1 Refrigeration Circuit

The expansion device consists of a standard (Sporlan) expansion valve equipped with a Level-Master (LMC). The bulb of a conventional thermostatic element has been modified to an insert-type bulb which incorporates a low-wattage electrical heater. The bulb is installed within a canister which is attached to the Low-Pressure Receiver (LPR). As the refrigerant level drops, electrically added heat increases pressure within the thermostatic element and opens the valve.

As the liquid refrigerant level raises, the electrical input is balanced by heat transfer from the bulb to the liquid refrigerant, and the LMC either modulates or eventually shuts off. Liquid flows from the condenser to a suction-line heat exchanger (tube in tube) where the refrigerant temperature is cooled approximately 10°F (5.5°C). The high-pressure liquid then enters the expansion valve flashing to intermediate pressure, enters the evaporator (bottom), and surrounds the evaporator tubes.

The evaporator is also coupled to the LPR employing a gravity-feed, constant liquid refrigerant recirculation effect. Gravity-feed liquid flows from the LPR, enters the evaporator (bottom), and mixes with refrigerant supplied from the expansion valve. A two-phase refrigerant flows from the evaporator into the accumulator, where dry suction gas is then returned to the compressor. Inside each evaporator tube is a free hanging  $\frac{3}{8}$ " (9.5 mm) stainless steel rod running the entire tube length. A plastic counter crank holds the whip rod in place, while a small pin is attached to the drive plate. The drive motor coupled to the drive plate rotates the attached whip rods continuously (approximately 800 rpm) during system operation. The drive is equipped with a soft-start system to reduce starting internal torque. A seal gasket provides an air-tight seal at the drive-shaft penetration point, located on the top plate. Solution pouring into the evaporator tubes and gravity drains gives up heat to the refrigerant, producing a boiling effect, pushing liquid/gas out the top. As two-phase refrigerant enters the LPR, gas velocity is reduced and the separated dry vapor is drawn into the compressor. The whip-rod spinning action creates a high agitation rate, increasing solution to tube surface contact. The end result is a highly efficient slurry ice maker (see Figure 7, "MaximICE Refrigeration Schematic Diagram," on page 15).

### 2.2 Ice-Build Circuit

The circuit consists of an insulated tank (ice storage tank) with necessary fittings for field plumbing. It **must** include an internal water spray system for "burning" ice uniformly during the melt mode. The ice slurry is pumped to the storage tank, filling the tank as shown from the top down. Once the ice inventory reaches the full ice, a temperature-sensing device will cycle the unit off.

## 2.3 Building Cooling Circuit

The circuit consists of a plate-and-frame heat exchanger, coolant pumps, and temperature regulating valve. Low-temperature glycol solution is pumped from the bottom of the ice storage tank into the plate-and-frame heat exchanger and returned over the ice pile via a spraying system. The spraying system may consist of a specially designed spray ball(s) drilled with holes or a spraying nozzle(s). Warm building load water is then pumped into the heat exchanger and cooled. Depending on the building, temperatures may vary from 37-42°F (3-6°C).

**NOTE:** The ORE glycol solution loop *must* incorporate a heat exchanger to separate the building process from the ORE solution loop. This reduces the amount of piping which carries the glycol solution, minimizing the cost and danger associated with piping leaks. All system fluid piping should be properly insulated.

## SECTION 3.0 - INSTALLATION

### 3.0 Installation

**NOTE:** It is very important in installations where the customer supplies certain components (ice storage tank, heat exchanger, valves, and/or fittings) that the following information and details are addressed. PMC shall not be held responsible for performance on systems constructed, piped, or designed differently than outlined in this manual.

### 3.1 Equipment Rigging

The MaximICE unit and ice storage tank must be lifted in accordance with industry practice. Lifting lugs and sleeves are not intended to be used for extended periods of time. The evaporator section is designed for four-point top lifting only. Please refer to equipment specifications section for weights.



**CAUTION: A spreader bar must be employed during the lifting process—failure to do so will result in equipment damage.**

### 3.2 Foundation

MaximICE units should be anchored to a concrete or structural steel base. Due to the varying conditions across the globe, it is recommended that an architectural engineer be consulted to determine the thickness of the concrete pad or structural steel in accordance with local codes. The concrete pad or structural steel must be level within  $\frac{1}{8}$ " (3 mm) to adequately support the refrigeration equipment.

### 3.3 Anchoring

According to local codes and practices, the refrigeration equipment should be welded or bolted down with appropriately sized hold-down anchor bolts (not furnished with equipment) and are to be securely anchored to the concrete pad by the customer. Refer to Figure 1 below for anchorage details. Polyethylene tank(s) will require tie-down straps. All applicable seismic zone regulations and proper construction practices should be considered in areas designed by the state.

**Figure 1 - Anchorage Details**

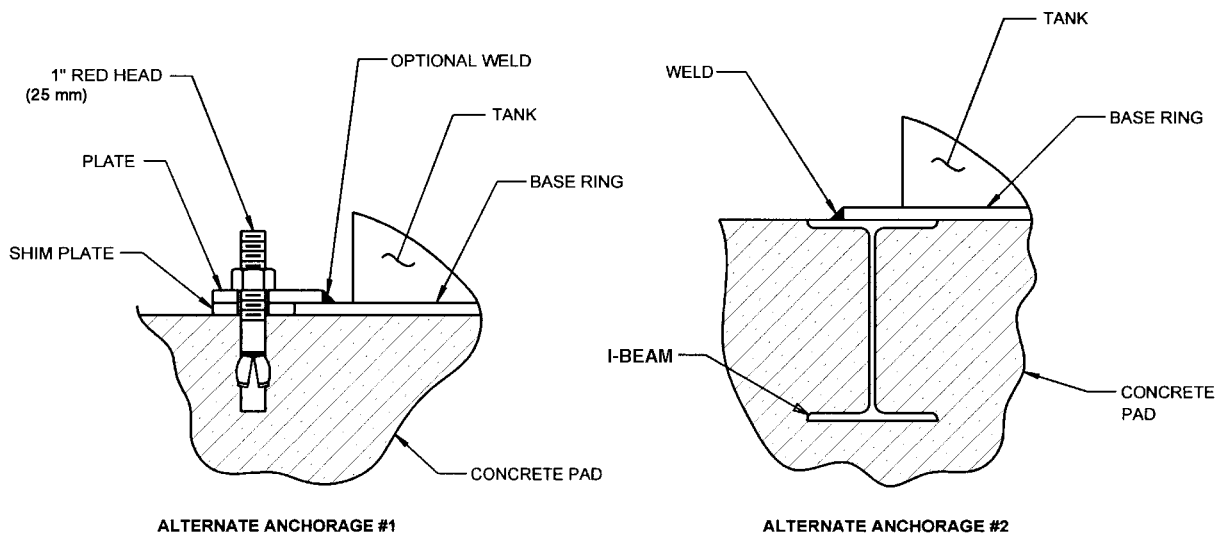

### **3.4 Serviceability**

Accessibility is required for servicing the equipment. A 3' (0.9 m) clearance around the evaporator compartment and a 4' (1.2 m) clearance above the top are required. Review the appropriate submittal drawing for exact required top clearance.

### **3.5 Shipping Charge**

All units are shipped with a dry nitrogen charge (approximately 5 psig/35 kPa) that is required to be bled off prior to installation. Extreme care must be taken while removing flanges or caps when the system is under pressure.

### **3.6 Remote Refrigeration Piping**

The refrigerant connections (suction, liquid) on the evaporator skid are sized based on the condensing unit located within 10' (3 m) of equivalent length tubing of the ORE skid. For systems with more than the equivalent 100' (30 m), increase tubing size accordingly. The liquid line should be sized to prevent excessive pressure drop to ensure a solid liquid column to the expansion valve. Use only Trade K or L refrigerant-grade tubing or Schedule 40 pipe. When brazing refrigerant tubing, an inert gas should be passed through the line at low pressure to prevent scaling and oxidation inside the tubing—dry nitrogen is preferred. Use suitable silver solder alloy on all refrigerant tubing. Refrigerant lines should be supported and fastened properly.

### **3.7 Refrigerant Piping Pressure Test**

After all lines are connected, the entire system must be leak tested, including the ORE and condensing unit. The complete system should be pressurized to not more than 150 psig (1,000 kPa) using dry nitrogen vapor. The use of an electronic-type leak detector is highly recommended due to its greater sensitivity of small leaks. It is recommended that this pressure be held for a minimum of four hours and then rechecked.

### **3.8 System Evacuation**

Prior to connecting hoses, remove the core from the Schrader fitting. A minimum evacuation to 500 microns and a five-minute hold period is recommended. Proper evacuation processes include vacuum pump oil changes and large-diameter, short-hose connections to both high and low sides of the system.

### **3.9 Refrigerant Charge**

See Section 5.0 for further details.

### **3.10 Condensing Unit**

Provide a suitable solid base under protective shelter with adequate air circulation. The most important consideration when determining the location of the air-cooled equipment is ambient air supply and removal of heated air to prevent air recirculation. A minimum distance of 3' (0.9 m) clearance should be provided for proper hot air removal and servicing.

The general rule of thumb for evaporative-cooled units is to allow a minimum distance around the unit of 6' (1.8 m) for smaller units and 8' (2.4 m) or more with larger units. Consult PMC for further details.

### 3.11 Electrical

The MaximICE wiring schematic identifies the minimum remote interconnecting field/customer wiring required. All power wiring and grounding must be installed in accordance with all local, state, and national codes. Separate field-supplied breaker/disconnect is required and shall be supplied by others. Article 440 of the NEC requires that the system have “disconnecting means capable of disconnection of air conditioning and refrigeration equipment including motor compressor and controllers from the circuits feeder.” The circuit breaker and/or fused disconnect switch should be selected and located within the NEC guidelines.

### 3.12 Electrical Specifications: ORE-25 (but not limited to)

**PLC:** 24 Volts, Inputs DC, Outputs AC, Power Supply 120 volts AC

**50 Hertz: Drive Motor  $\frac{3}{4}$  Horsepower**

200 volts  
3.5 amps ( $\pm .2$ )  
762 rpm

**50 Hertz: Drive Motor  $\frac{3}{4}$  Horsepower**

380 volts  
1.75 amps ( $\pm .2$ )  
857 rpm

**60 Hertz: Drive Motor  $\frac{3}{4}$  Horsepower**

208 volts  
3.7 amps ( $\pm .2$ )  
794 rpm

**60 Hertz: Drive Motor  $\frac{3}{4}$  Horsepower**

230 volts  
3.05 amps ( $\pm .2$ )  
794 rpm

**60 Hertz: Drive Motor  $\frac{3}{4}$  Horsepower**

460 volts  
1.53 amps ( $\pm .2$ )  
833 rpm

**60 Hertz: Drive Motor  $\frac{3}{4}$  Horsepower**

380 volts  
1.75 amps ( $\pm .2$ )  
794 rpm

### 3.13 Electrical Specifications: ORE-50 (but not limited to)

**PLC:** 24 Volts, Inputs DC, Outputs AC, Power Supply 120 volts AC

**50 Hertz: Drive Motor 1.5 Horsepower**

200 volts  
6.0 amps ( $\pm .2$ )  
850 rpm

**50 Hertz: Drive Motor 1.5 Horsepower**

380 volts  
3.0 amps ( $\pm .2$ )  
850 rpm

**60 Hertz: Drive Motor 1.5 Horsepower**

208 volts  
5.2 amps ( $\pm .2$ )  
850 rpm

**60 Hertz: Drive Motor 1.5 Horsepower**

230 volts  
4.75 amps ( $\pm .2$ )  
850 rpm

**60 Hertz: Drive Motor 1.5 Horsepower**

460 volts  
2.35 amps ( $\pm .2$ )  
850 rpm

### 3.14 Electrical Specifications: ORE-100 (but not limited to)

**PLC:** 24 Volts, Inputs DC, Outputs AC, Power Supply 120 volts AC

**50 Hertz: Drive Motor 3 Horsepower**

200 volts  
13.8 amps (± .2)  
850 rpm

**50 Hertz: Drive Motor 3 Horsepower**

380 volts  
6.9 amps (± .2)  
850 rpm

**60 Hertz: Drive Motor 3 Horsepower**

230 volts  
12.6 amps (± .2)  
850 rpm

**60 Hertz: Drive Motor 3 Horsepower**

460 volts  
6.3 amps (± .2)  
850 rpm

### 3.15 Ice Storage Tank - Full Ice Sensor Option

To determine a full ice storage tank condition, a temperature bulb is mounted in the evaporator solution inlet which sends a signal to a digital temperature controller located in the PMC control box. As the amount of ice increases within the storage tank, the glycol percentage increases and lowers the solution freeze point. At approximately 24 to 26°F (-4.4 to -3.3°C) the PLC receives an input from the controller initiating a full ice shutdown.

### 3.16 Ice Storage Tank - Vent Line

To ensure proper solution flow, a vent system is incorporated. Attach the vent line to the top of the ice storage tank top. The line must be mounted to ensure full draining, with no loops or kinks.

### 3.17 Ice Storage Tank - Spraying System

To ensure that the stored liquid ice is burned efficiently and a low-temperature supply solution can be maintained to the cooling loads, spray device(s) must be used to distribute the warm solution over the liquid ice. For field-fabricated storage tanks, spray distribution system should be supplied in sufficient numbers and location, based upon spray pattern, to provide maximum coverage over the liquid ice. Please consult PMC for field-fabricated storage tank spray distribution systems.

### 3.18 Glycol Solution Specification

The MaximICE TES system uses a very low concentration of propylene or ethylene glycol solution as the storage medium to promote the growth of the ice crystals.

**Glycol Manufacturer-Supplied Information—**

The following information should be provided to the owner:

- ▲ Manufacturer's name, address, and telephone numbers.
- ▲ Material safety data sheet.
- ▲ Instruction for system cleaning, flushing, and testing of system water prior to charging.
- ▲ Off-season lay-up of equipment.

**Solution Additives—**Prior to filling and charging the storage tank, the interior of the tank and all piping runs should be thoroughly cleaned to remove pipe scale, dirt, and other impurities. The system should also be checked for leaks at this time.

**It is imperative that these guidelines be followed.** Since the concentration in the tank will be between 7.0% and 7.5% (by weight), the additives present in the HVAC-grade inhibited glycol will not be sufficient to protect the system from corrosion and bacterial growth. Dipotassium phosphate ( $K_2HPO_4$ ) **must** be used as a corrosion inhibitor to protect steel and stainless steel components at a concentration no less than 4,000 ppm as  $PO_4$  (7,350 ppm as dry  $K_2HPO_4$ ). An azole-type corrosion inhibitor **must** be added to protect copper and brass components. The best choice is halogen-resistant azole like BetzDearborn AZ8104 (10 ppm). Alternatively, one may use tolyl triazole (30 ppm of typical formulation with approximately 20% active ingredient). Anti-foaming agents (such as Dow Corning 1410) may also be added as needed.

To inhibit bacterial growth, add 200 ppm of quaternary amine. Typical quaternary amines are  $C_{12}$  to  $C_{18}$  mixtures of n-alkyl dimethyl benzyl ammonium chloride or n-alkyl dimethyl ethyl benzyl ammonium chloride. Manufacturers include Albemarle Chemical (BQ 451-5), Lonza (Barquat 50-65), and Stepan Company (BTC 818).

Dry ingredients (such as dipotassium phosphate) **must** be dissolved in water prior to addition to the ice slurry tank. A small tank and mixer is convenient for this purpose.

**Water Quality**—Water used to make up the glycol solution must meet certain standards of purity. Distilled or de-ionized water is recommended. Levels of chlorides and sulfates should be less than 25 ppm each. Total hardness should be less than 100 ppm expressed as ppm calcium carbonate. If good quality water is unavailable, pre-diluted solutions are available from manufacturers.

Local conditions must always be taken into consideration, particularly when it comes to biofouling and scaling/fouling deposits. A local water-treatment authority should be consulted for guidance in this matter. PMC recommends calling your county or city water department to find out the specification of your local water supply. If the water contains less than 100 ppm of hardness, it can be used to dilute your glycol-based heat transfer fluid. Another option would be to test the water yourself with a HACH test kit.

One word of caution about the common practice of using softeners when filling HVAC systems: resins typically used in these softeners will replace the calcium and magnesium ions with sodium ions. This, in itself, is fine. However, these resins do not sufficiently reduce high concentrations of chloride or sulfate ions. To accomplish the latter, another type of ion exchange resin must be used. Resins that remove calcium and magnesium ions are typically regenerated with a strong brine solution, and the excess sodium chloride is flushed out as waste water. This must be followed by thoroughly flushing the regenerated resin bed with water. Otherwise, an excess of chloride ions will be flushed into the so-called good quality water. Glycol manufacturers recommend using de-mineralized water that has been distilled, de-ionized, or passed through a reverse osmosis (RO) process to remove certain minerals and salts.

**Good water quality is typically defined by the following parameters:**

- ▲ Less than 50 ppm of calcium
- ▲ Less than 50 ppm of magnesium
- ▲ Less than 100 ppm (or 6 grains) of total hardness
- ▲ Less than 25 ppm of chloride
- ▲ Less than 25 ppm of sulfate

After combining the proper amounts of water and inhibited glycol, the system should be mixed for a minimum of four hours to achieve uniformity. This can be accomplished with the MaximICE feed and solution pumps or with the cooling load pump. Solution concentration should be verified using a refractometer to measure Refractive Index (RI).

The supplier of the glycol should be consulted to determine correct RI for the inhibited solution used at the temperature tested. Adjustments to the solution may be necessary to achieve the correct concentration. This should always be done prior to starting the MaximICE system, as glycol concentration will change as the production of liquid ice begins. An accurate measurement of the concentration of glycol can be accomplished using a hand-held refractometer. This instrument is portable, requires only a few drops of fluid, and needs no adjustment for fluid temperature. PMC recommends that the glycol solution be tested every month (see Maintenance and Service Manual). It is also recommended that the owner test the alkalinity four times per year for the first year and annually after that.

**Glycol Solution Concentration Adjustments**—It is sometimes necessary to increase or decrease the concentration of the glycol solution in your system to replace fluid lost through leakage or moisture absorbed from the atmosphere. Either adjustment can be carried out in batch or continuous operation.

**Procedure for Adjusting Freezing Point of Glycol Fluids**—If the concentration of glycol must be increased, use the formula below to determine the amount of solution to drain and the number of gallons of glycol to add to increase glycol concentration.

$$A = V(D-P)/(100-P)$$

To decrease the glycol concentration, the following formula should be used to determine the volume to drain and replace with high-quality water:

$$A = V(P-D)/P$$

Where:

A = The quantity (in gallons or m<sup>3</sup>) of glycol to be added to the system to lower the freeze point or the quantity (in gallons or m<sup>3</sup>) of glycol solution that must be drained from the system to decrease glycol concentration.

V = The total solution capacity of the system in gallons or m<sup>3</sup>.

D = The volume percent of glycol desired in the system.

P = The volume percent of glycol presently in the system.

### 3.19 Freeze Protection

Units located outside shall require freeze-up protection (heat tape on all solution lines). A glycol solution is required for the MaximICE system; however, during low ambient conditions (outside temperatures below 27°F or -3°C), the solution may freeze and cause piping damage.

### 3.20 Insulation

All glycol solution piping should be insulated with 2" (50 mm) polyfoam/Armaflex to prevent external heat gain. The ice storage tank(s) supplied by PMC (polyethylene type) must be placed on top of at least 3" (75 mm) of styrofoam with a loading strength of 25 psi (175 kPa). Heat gain and proper insulation practices should be considered for concrete tanks constructed on site.

### 3.21 ORE Drive Assembly

The drive system is designed with very close tolerances to ensure proper clearance, water sealing, and operation of all drive components extreme caution should be taken during installation.



**CAUTION: Do not operate drive system without circulating glycol solution.**

**NOTE:** Refer to Figures 3 through 6 with the following drive installation steps:

- ▲ Using a flashlight, inspect each tube for any foreign debris.
- ▲ Apply a thin coat of petroleum jelly on each counter crank prior to installing (lower end, top edges).

- ▲ Working clockwise at the alignment mark, place each countercrank in a left-hand/right-hand arrangement. Countercrank type is determined by positioning the drive pin at six o'clock and checking the slot point direction.

**NOTE:** The ORE-50 and 100 have several countercranks that may appear out of sequence. See the appropriate layout drawing for specific alignment.

- ▲ Install each whip rod.
- ▲ Position all drive pins towards the evaporator top tube sheet alignment mark.
- ▲ Install lower rubber gasket.
- ▲ Install drive plate by matching the top tube sheet alignment mark with the drive plate.

**NOTE:** The evaporator top sheet and drive plate are labeled with an alignment mark(s) to ensure proper assembly.

- ▲ Install clear PVC top water chamber.
- ▲ Install upper rubber gasket.
- ▲ Install top head.
- ▲ Install drive motor. Adjustments can be made to the eccentric crank during assembly by rotating the motor fan blades with small screwdriver.
- ▲ Tighten top plate mounting bolt using a star pattern while tightening bolts.
- ▲ Adjust motor for approximately  $\frac{1}{16}$ " (1.6 mm) clearance between the eccentric crank and drive plate bearing (no pressure on drive plate).

**Figure 2 - ORE Drive Assembly Detail**

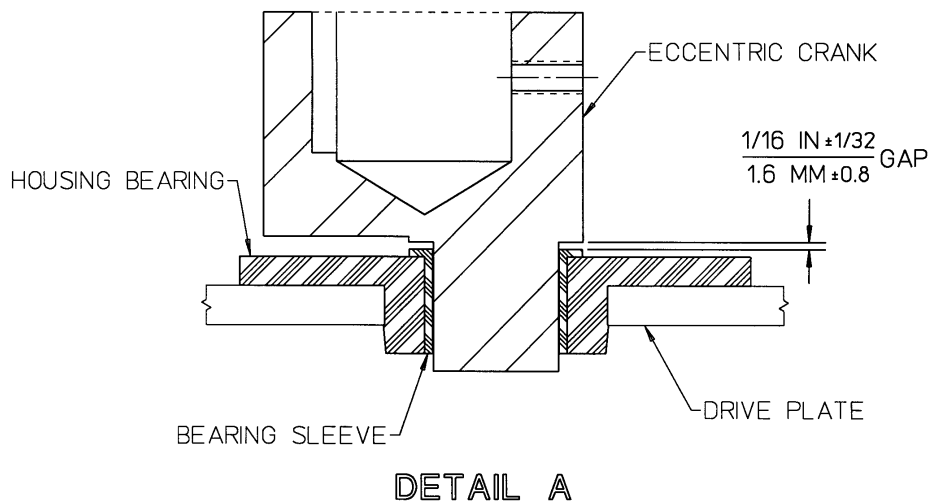

### 3.22 Gravity Feed System

A gravity feed ice-discharge system, with a telescopic-type housing mounted to the evaporator (bottom) that extends into the ice opening, is incorporated for systems where the evaporator is installed on top of the ice storage tank. A watertight seal must be applied once the unit is set in place and the housing is lowered into the opening. The gap (about  $\frac{1}{2}$ "/12 mm) can be filled with insulation rope and sealed with a layer of silicone.

**Figure 3 - MaximICE ORE-25 Drive Assembly**

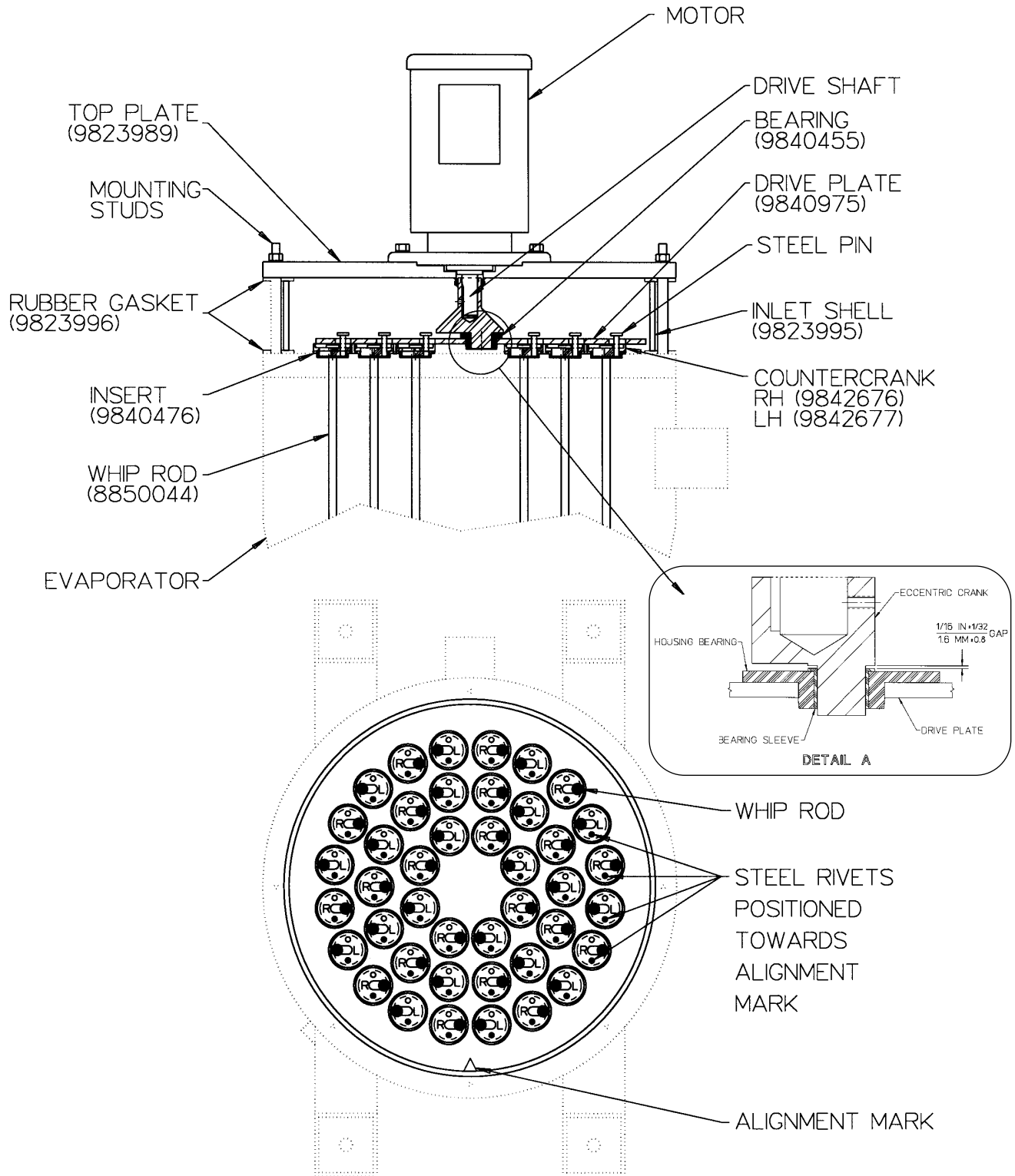

8200062-1 P1

**Figure 4 - MaximICE ORE-50 Drive Assembly**

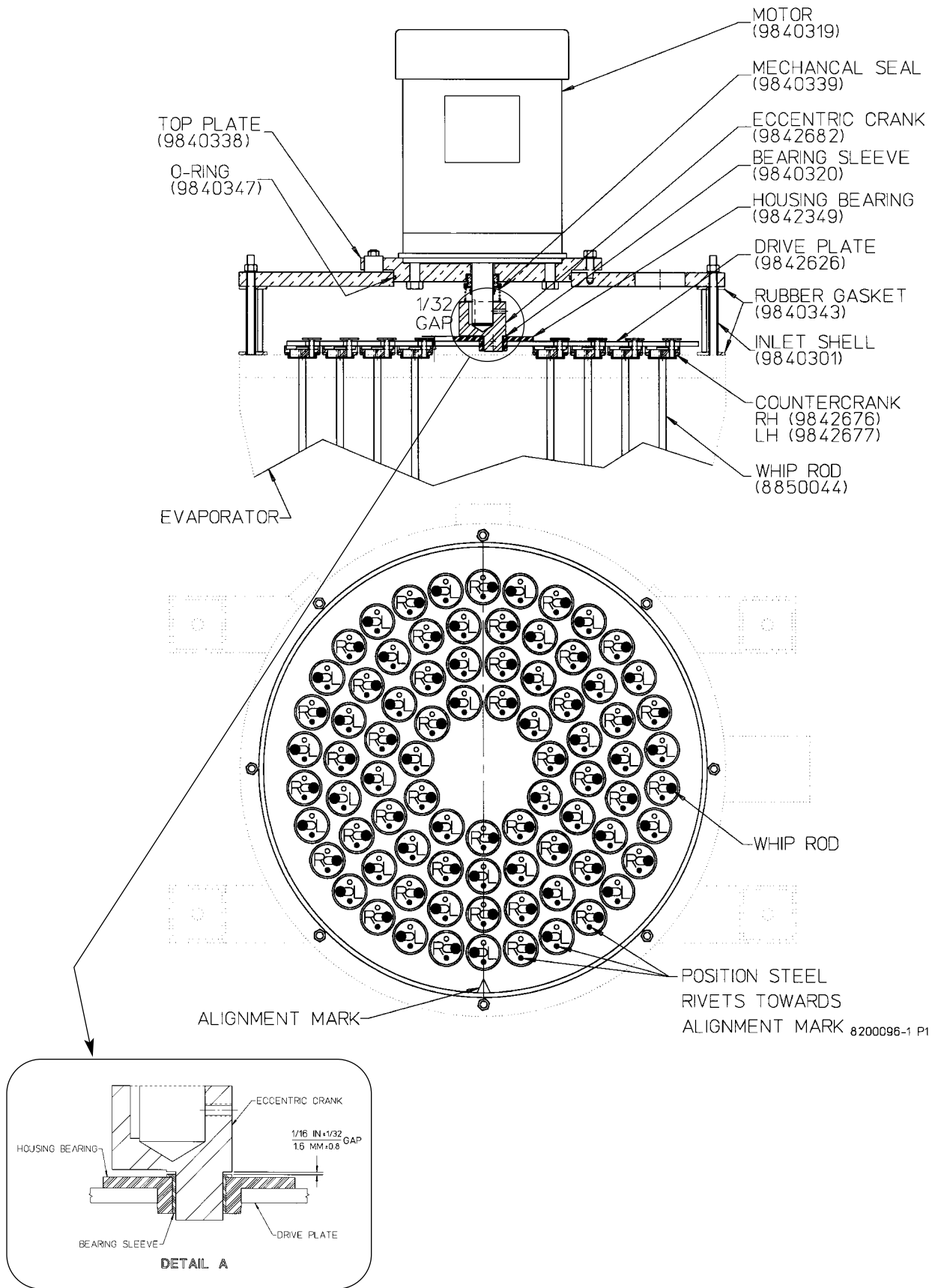

**Figure 5 - MaximICE ORE-100 Drive Assembly**

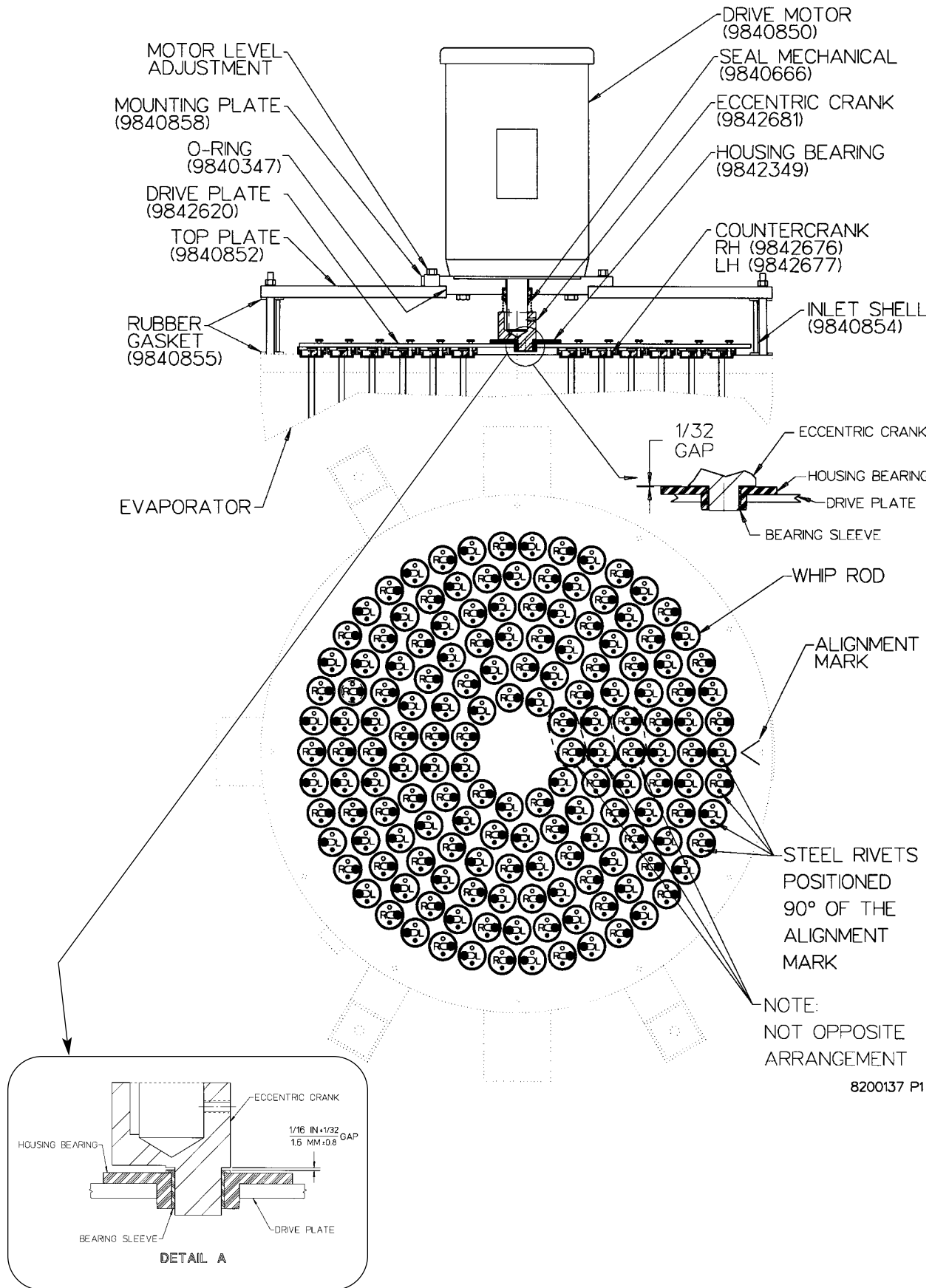
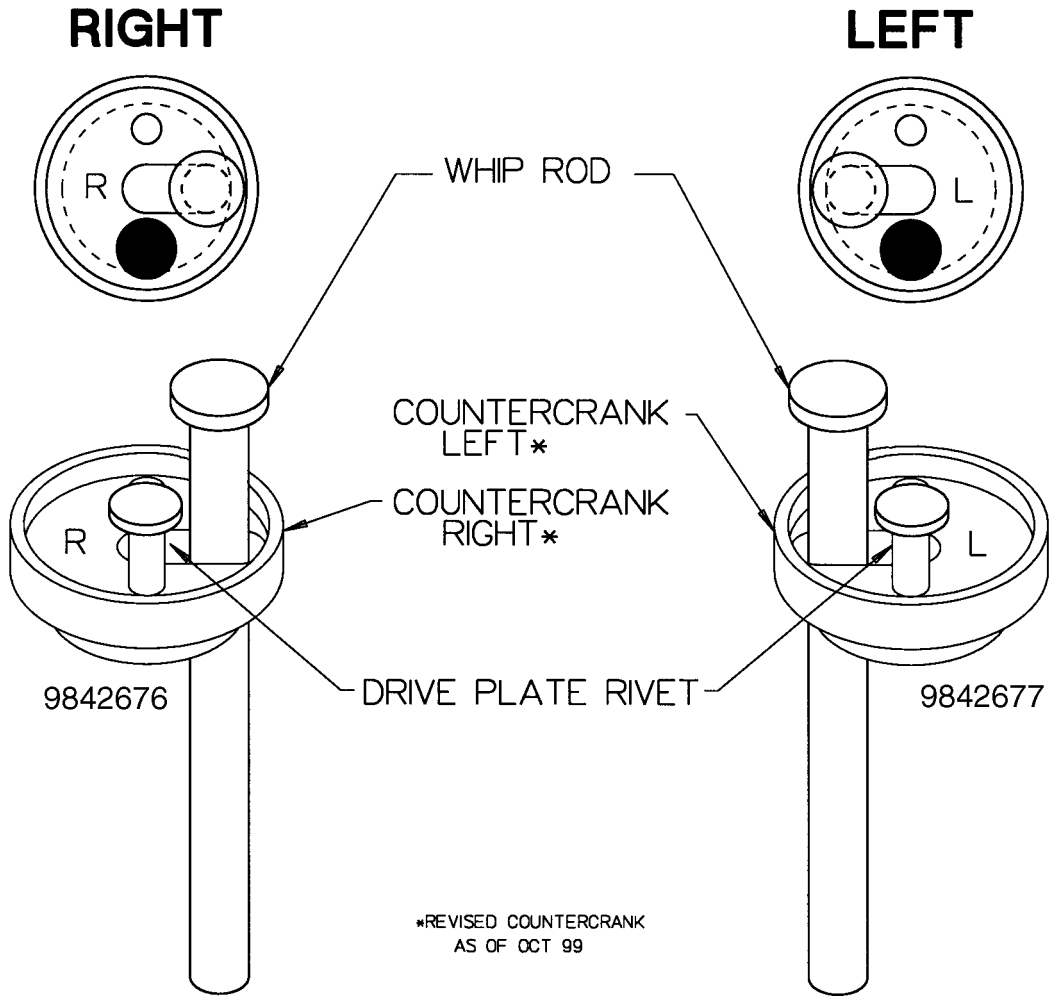

Figure 6 - ORE Countercrank Assembly



8200135 P1

### 3.23 Packing Material(s)

The whip rods are secured in place with cellophane wrap, which must be removed from the bottom of each evaporator. On units with an ice discharge pump option, the outlet manifold ships loose and should be installed after the cellophane wrap.

**Figure 7 - MaximICE Refrigeration Schematic Diagram**

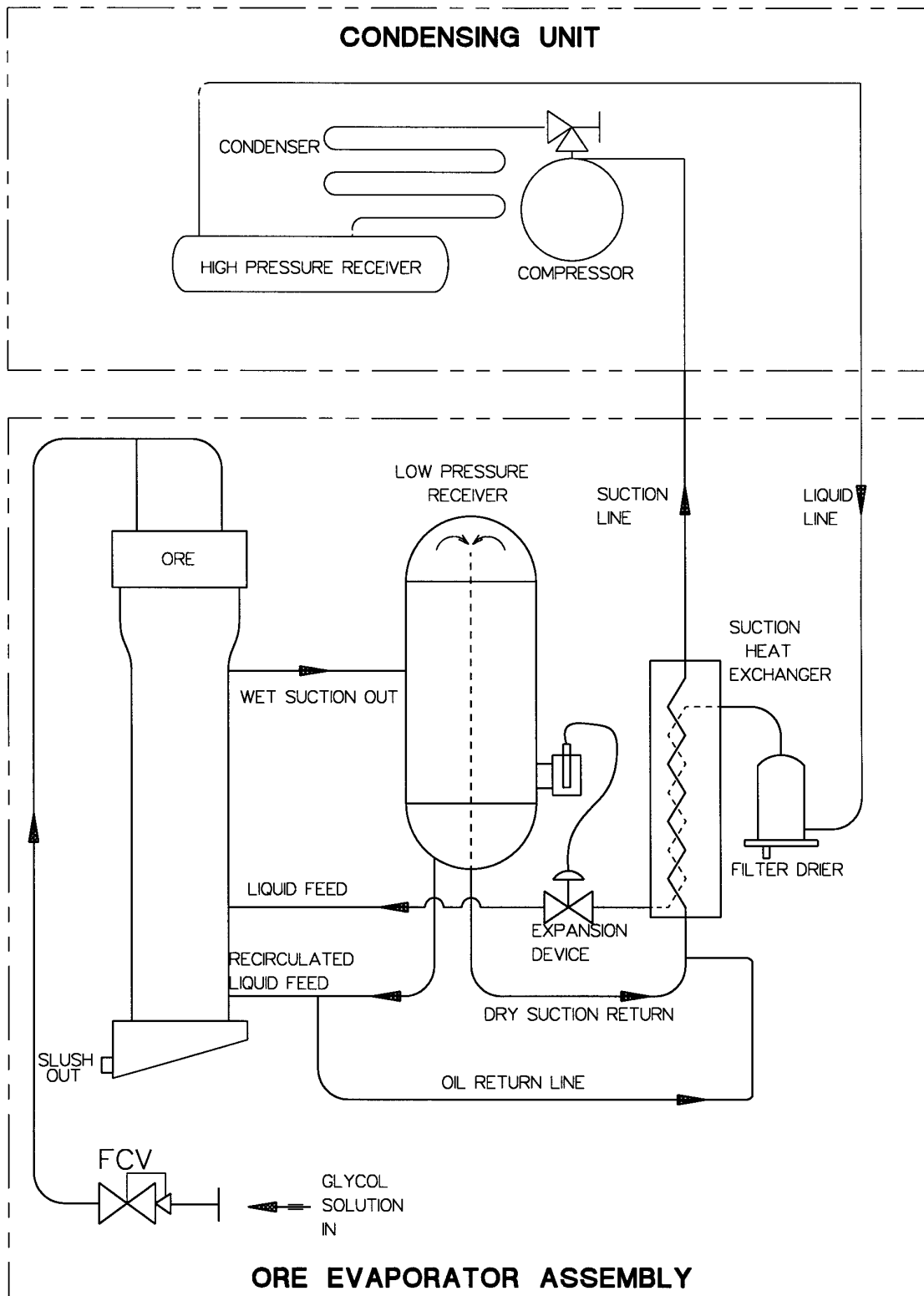

## SECTION 4.0 - PRE START-UP/INSTALLATION REQUIREMENTS

### 4.1 Evaporator Unit Drive

The unit must be level within  $\frac{1}{8}$ " (3 mm) over the entire length and width of the evaporator compartment (shim and grout as necessary).

The unit must be uniformly supported along the base beams.

The unit must not have restricted access. At least 4' (1.2 m) of clearance is required on all sides of the unit. Service access must be provided for removal of whip rods (approximately 4' or 1.2 m above evaporator compartment). Do not suspend or support any piping or conduit from this unit.

This unit contains rotating equipment, thus vibration and sound control may be required for this unit. Where vibration may be transmitted to a structure, all external piping to the unit should be vibration isolated.

### 4.2 Water Loop/Piping

All piping must be complete and correctly installed.

Water piping shall be flushed and drained prior to final connection to the MaximICE. The flushing procedure shall use an environmentally approved cleaning solution and consist of flushing the piping at not less than 10 ft/sec (3 m/sec) velocity for six hours. The water piping shall then be flushed with clean water to remove any residue.

All exposed exterior water piping shall be heat traced and insulated. The Paul Mueller Company warranty specifically excludes any liability for freezing damage resulting from low ambient temperatures.

The ice storage tank must be cleaned with an approved cleaning solution and rinsed with clean water prior to adding water/glycol solution. The water piping system, including the tank, shall then be filled with clean water and 7% glycol to 60% of the height of the tank. The water/glycol solution should be analyzed by a water-treatment authority and properly treated for oxygen corrosion, scales, algae, and fungus growth. The water should be periodically checked by a water-treatment authority.

Water-cooled condenser water piping shall be cleaned and flushed to remove all debris. The condenser/cooling tower water shall be properly treated. A properly sized strainer should be used on the condenser water supply to the MaximICE. The condenser, condenser water piping, condenser pump, and cooling tower must be properly protected against freeze damage resulting from low ambient temperatures.

Evaporative condensers shall be flushed and properly treated. A proper water-treatment system usually consists of a continuous blow down and chemical feeder. The condenser, condenser water piping, condenser water make-up line, and pump must be properly protected against freeze damage. The Paul Mueller Company warranty specifically excludes any liability for damage resulting from low ambient temperature. **Failure to maintain proper operation of the condenser by allowing fouling will result in decreased MaximICE system performance and operation.**

Water-cooled units may be provided with a condenser water-regulating valve, which is shipped loose for field installation at the outlet side of the condenser.

Remote, evaporatively cooled, air-cooled condenser or cooling towers, when supplied by other than PMC, require head pressure/capacity control. Consult factory for details and minimum requirements.

(If applicable) Water cooled oil cooler, if installed, shall be connected by the installing contractor to a water source with a maximum water temperature of 85°F (30°C), with the required flow rate shown on the submittal. Supply water piping must be properly protected against freeze damage by the installer.

### 4.3 Electrical

All power wiring and grounding must be installed in accordance with all local, state, and national codes. All wiring to the MaximICE shall be copper—do not use aluminum wire.

The following control interlocks must be installed prior to operating the unit:

**Water flow**—Proof of condenser water flow is required. Either a flow switch or a pressure differential switch can be employed.

**For a remote, evaporatively cooled condenser**—Proof of condenser water pump and fan operation is required.

**For a remote, air-cooled condenser**—Proof of operation or signal upon a unit failure is required.

### 4.4 Refrigerant Piping

The installing contractor shall provide and install all interconnection piping and service valves. All refrigerant (R-22) piping shall be Type L or K hard copper or Schedule 40 steel piping. All piping shall be purged with an inert gas during welding or brazing. Ammonia (R-717) must be piped per ASHRAE 15 latest revision.

A pressure leak test of the complete refrigeration system is required once field piping is complete. The system shall be proven tight at 25 psig (175 kPa) below the lowest setting pressure relief valve.

The entire system must be evacuated to at least 500 microns with a five minute hold period.

The contractor shall provide a charging line from the charging connection on the MaximICE unit to the charging drum(s).

### 4.5 Start-Up Coordination/Inspection

Upon arrival of PMC authorized start-up personnel at the job site, a start-up coordination meeting will be held and a walk-through inspection of the job site conditions will be conducted. All trades involved in the installation should be represented. This includes, but is not limited to, the general contractor, mechanical contractor, plumbing contractor, tank contractor, and owner's representative. The start-up will not continue until all requirements for correct and safe operation of the MaximICE are satisfied. The installing trades should be available to resolve installation problems as required during the start-up period.

Contractors' personnel and the owner's representative who will be operating and maintaining the unit should be available for training during the entire start-up period.

### 4.6 Start-Up Policy

MaximICE units require two, three, or four days of start-up assistance depending on the size of equipment. Delays in the start-up caused by failure to comply with any of the following procedures are not the responsibility of PMC. Additionally, start-up time caused by delays, not the responsibility of PMC, must be authorized by customer in advance. Failure to follow these procedures will result in delays and may result in the voiding of the equipment warranty. Contact the Paul Mueller Company Thermal Energy Storage Department if you have any questions pertaining to the installation requirements of this equipment.

## SECTION 5.0 - START-UP/REFRIGERANT CHARGING

### 5.0 Start-Up/Refrigerant Charging

Apply main power at least 12 hours prior to starting unit. This will allow the compressor crankcase ample time to boil off any possible liquid refrigerant within the compressor.

**NOTE:** Refrigerant charges provided are conservative and will vary due to condenser type and equipment layout. Final charging will be necessary once the system is under a stable operating condition.

#### **Approximate refrigerant charge(s):**

- ORE-25 = 400 lbs (180 kg)
- ORE-50 = 700 lbs (320 kg)
- ORE-100 = 1,000 lbs (450 kg)

Locate the  $\frac{5}{8}$ " flare fitting on the ORE evaporator. Only this fitting can be used to charge the system with liquid refrigerant. Add refrigerant to bring the pressure up, and equalize prior to starting. Continue to add refrigerant until a 10% liquid level is reached in the high pressure receiver during normal operation.

The air/evaporative condenser package is equipped with a fan cycling head-pressure control system, which maintains a minimum compressor discharge pressure during low ambient conditions (175 psig/1,200 kPa).

## SECTION 6.0 - SEQUENCE OF CONTROL

### 6.0 Sequence of Control

The operation of the MaximICE unit is controlled by a Programmable Logic Controller (PLC), a very reliable, continuous-duty, automatic control device. By observing LED input/output lights, the operational status can be determined, serving as a useful tool during troubleshooting. It is recommended to study the system wiring diagram while matching the proper input/output LED lights with each function. Exhaust all other possible failure causes before assuming a PLC control malfunction. It is highly unlikely that the program is causing a failure.

The on/auto/off switch located in the control enclosure facilitates unit operation within the panel. A manual switch reset is required after a system failure shutdown. The MaximICE unit is programmed with a unique system start-up and shutdown sequence unlike common refrigeration equipment. The following information describes a typical system operation sequence.

**NOTE:** The PLC is equipped with dual, low-voltage 24V; input side is 24VDC and output side is 24VAC.

### 6.1 Start-Up Sequence

- ▲ Select either “MANUAL” or “AUTO” on local 3 position toggle switch.

**MANUAL**—System starts immediately.

**AUTO**—System starts when remote “Enable” signal is received.

- ▲ Slush pump and feed pump on.
- ▲ Enable temperature sensor while system fluid circulates for 5 minutes.
- ▲ End of 5-minute circulation. Check to see if high ice condition exists:
  - No full ice condition—Drive motor, pump-down solenoid, and LLM heater are energized. Continue start-up.
  - Full ice condition exists—System shutdown on full ice.
  - Periodically, the system shall restart the glycol solution to verify a full ice condition. If full ice exists after a 5-minute check, the system should remain off.
- ▲ 10-seconds delay after drive is on—Condensing unit, oil return solenoid, and unload solenoid(s) are energized; system operates unload for 2 minutes. At the end of 2 minutes, the unload solenoid(s) are de-energized, allowing for full load compressor capacity.
- ▲ Start-up sequence complete.

### 6.2 Shutdown Sequence

- ▲ Shutdown initiated by either selecting “OFF” on the toggle switch, removing the remote enable signal (if in AUTO), or “high ice” condition (temperature set point reached) in tank.
- ▲ Unload solenoids on 5-minute delay.
- ▲ End of 5-minute delay—Condensing unit, oil return solenoid, unload solenoid, and LLM heater turn off.
- ▲ After 15-minute delay—drive shuts down.

- ▲ End of 30-second delay—Slush and feed pump shut down.
- ▲ Shutdown sequence complete.

**NOTE:** When a unit shutdown is initiated for any reason, the unit will complete the shutdown sequence before a restart is enabled. If the unit is in the process of starting, the start-up sequence will be completed before the shutdown sequence begins. **If an immediate shutdown is required, the “E-STOP” switch must be pushed.**

### 6.3 Restart Sequence

60-minute (typical) delay for restart after full ice condition—Unit will automatically start the solution pump(s) and check for absence of full ice condition. If full ice exists, the pumps shall shutdown and another 60-minute delay will take place and the restart process will repeat.

- ▲ Pressing the “E-Stop” push button or an alarm condition will initiate shutdown.
- ▲ All operating components are de-energized immediately.
- ▲ Toggle switch must be moved to “OFF” position to reset alarm condition after shutdown is complete.
- ▲ Alarm status.

### 6.4 Alarm Condition Sequence

- ▲ Condensing unit alarm—Compressor motor overload, high discharge switch, and low oil pressure switches are wired in series.
- ▲ Motor overload—Drive motor, slush pump, and solution pump in series.
- ▲ Freeze-Up Protection—Evaporator low pressure switch set for (3 psi/20 kPa to 5 psi/35 kPa) below normal operating pressure (lowest).
- ▲ High-level solution vent line switch—Ice slurry discharge from ORE interruption.
- ▲ Glycol solution flow switch—Glycol solution feed to ORE interruption.
- ▲ Emergency stop.

### 6.5 Additional Control Elements

- ▲ Vent switch intermediate trip/alarm:
  - a. Vent switch must be tripped for 10 seconds before intermediate trip condition.
  - b. Condensing unit will shut down for 10 minutes while the rest of the system continues to function as usual.
  - c. After 10 minutes:
    1. Vent switch clear. Condensing unit restarts.
    2. Vent switch not clear. System shutdown on vent alarm. If intermediate trip condition occurs three times in 30 minutes, system shuts down on vent alarm.
- ▲ High vent switch—The entire unit shuts down after a 5-second delay.
- ▲ Drive motor will not operate when the high temperature solution feed indicates glycol temperatures above 55°F (13°C).

## SECTION 7.0 - SAFETY

### 7.1 Label, Danger, "Unit Starts Up Automatically"

The unit is intended to operate automatically and will start at any time. Power must be disconnected and locked-out when servicing the unit.



### 7.2 Label, Electrical Symbol, Part No. 8820623

Indicates the high voltage electrical components of the system.

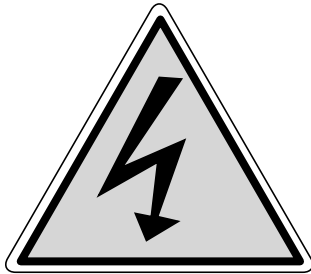

### 7.3 Label, Danger, "High Voltage"

This unit should be serviced by qualified electrical and refrigeration technicians.

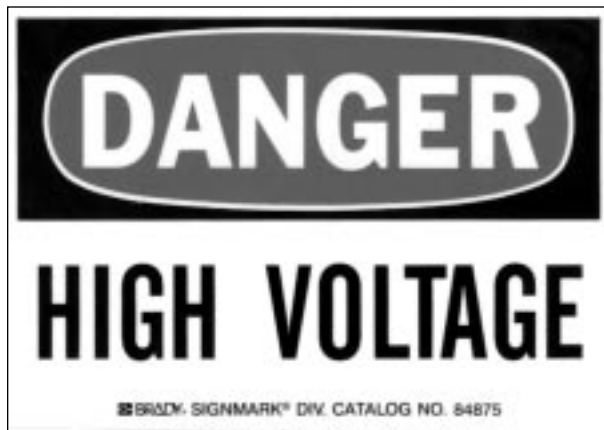

#### 7.4 Label, Caution, "Do Not Run Unit Dry," Part No. 8850229

Major damage will occur if the drive parts are ran without the solution.



#### 7.5 Label, Caution, "If this Gap Measurement...," Part No. 9842772

If the bearing gap is not set correctly, it will cause the failure of the drive bearing and the drive plate.



#### 7.6 Equipment dB Readings

The equipment's dB readings. (A weighting, taken during ice-making at 3 feet (1 M) from evaporator are listed below.)

ORE-25	ORE-50	ORE-100
75	75	78



**WARNING: When operating or servicing the equipment, adequate hearing protection must be used.**

## SECTION 8.0 - MAINTENANCE

### 8.0 Maintenance

The MaximICE system is designed to be a low-maintenance piece of equipment. Preventive maintenance is the key to a properly operating unit. It is recommended to maintain an inspection log book for tracking the history of operation.

### 8.1 Daily Checks

- ▲ Inspect the ORE unit for solution leaks and excessive vibrations. Check for proper compressor suction pressure and temperature.
- ▲ Inspect around ice storage tank for solution leaks (piping, fittings, and tank surface).
- ▲ Check for oil spots around condensing unit.
- ▲ Listen to compressor for any noises different than normal. Sound level(s) should be constant.
- ▲ Listen to the ORE. The whip rods should make a sibilant noise (sh...). Rattling noises may indicate one or more frozen tubes.

### 8.2 Recommended Inspection Procedures

The following points should be inspected when performing preventive maintenance on the MaximICE thermal energy storage system.

#### ▲ Drive Component Inspection—

- a. Turn the on/auto/off control switch inside the ORE control panel to the off position. At this time, the liquid line solenoid and the oil return solenoid will close and the unit will pump down.
- b. After the pumps and the drive assembly stop, turn the main power off to the unit.
- c. Remove the insulation from the inlet shell and set aside.
- d. Remove the inlet solution header (this will consist of removing 8 flange bolts and 2 union fittings).
- e. On the top plate there will be 12  $\frac{9}{16}$ " nuts. Remove all 12 nuts and the lock washers. (NOTE: Do not remove the motor.) If this preventive maintenance is performed on an ORE-100, 200, 300, or 400, and a hoist is not available, the motor may have to be removed due to the weight and the awkwardness of the drive motor and top plate. If you have to remove the motor, the following steps must be followed: There are three  $\frac{3}{4}$ " bolts with a lock nut on the bolt. Remove the  $\frac{3}{4}$ " bolts from the motor mounting plate, not the adjusting inserts. This will allow the motor to be removed by lifting it along with the motor lifting lugs that are provided with the motor straight up.
- f. With the motor and the top plate removed, the drive plate will be visible. Carefully lift the drive plate up and out of the evaporator and set aside.
- g. With the drive plate removed, the counter cranks and the tops of the whip rods will be exposed. You will notice they are configured in a left and right format. Refer to Figures 3, 4, or 5 for counter crank arrangement. Randomly pull 8 to 10 counter cranks, along with the whip rods, out of the evaporator for inspection. Look at the counter cranks to see if there is any sign of scoring or frictional wear. If so, refer to the tolerance chart to see if these parts need to be replaced or if they are in specification. Then they can be reinstalled in the evaporator and returned to service.

▲ **Drive Plate—**

With the drive plate removed and placed on a flat surface, check all the holes and make sure the holes in the drive plate are round and not elongated. If there are any holes that are out of round, please refer to the tolerance chart to see if the drive plate can be reinstalled or if it needs to be replaced.

**Figure 8 - Drive Plate Inspection Criteria**

**3/4" HOLE DRIVE PLATE**

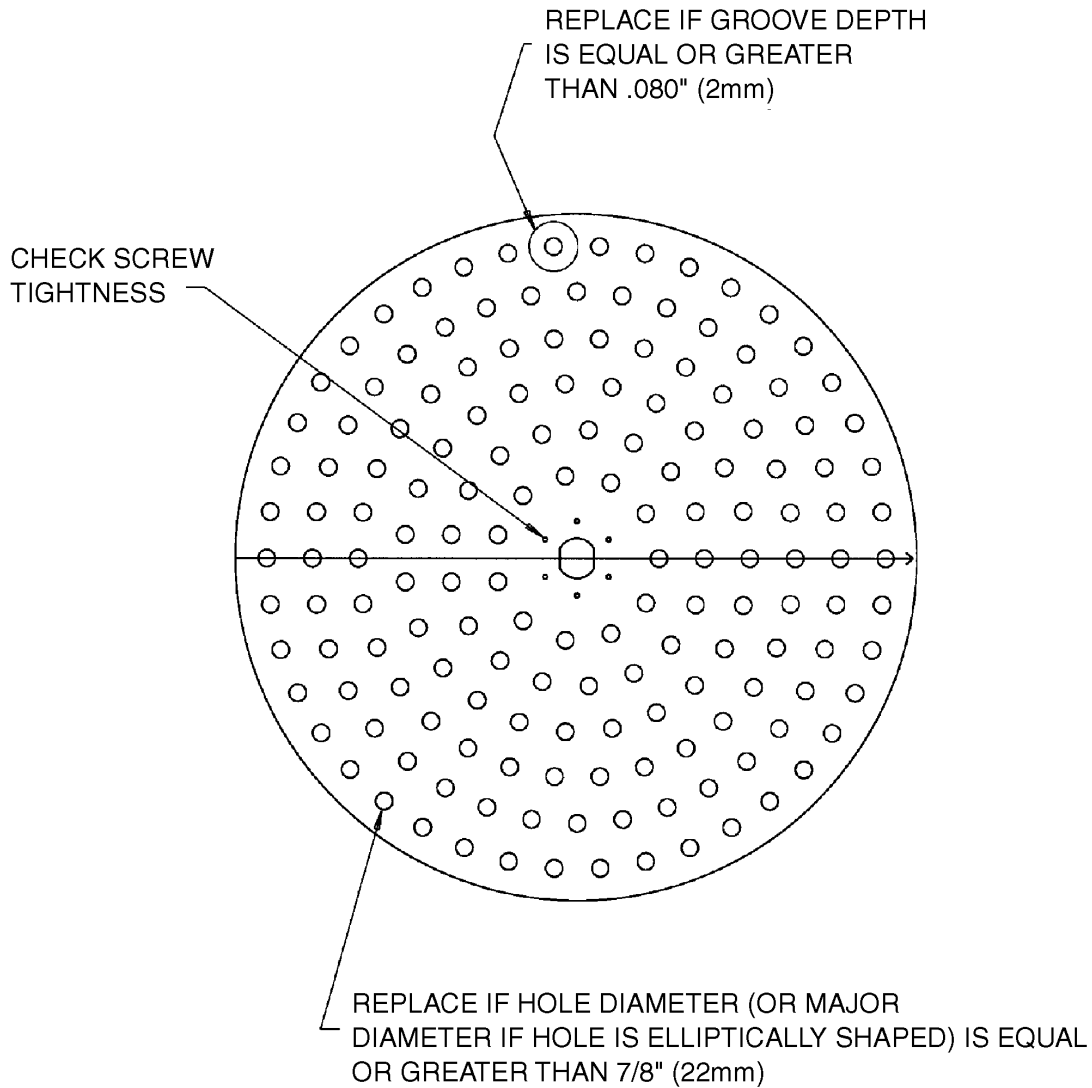
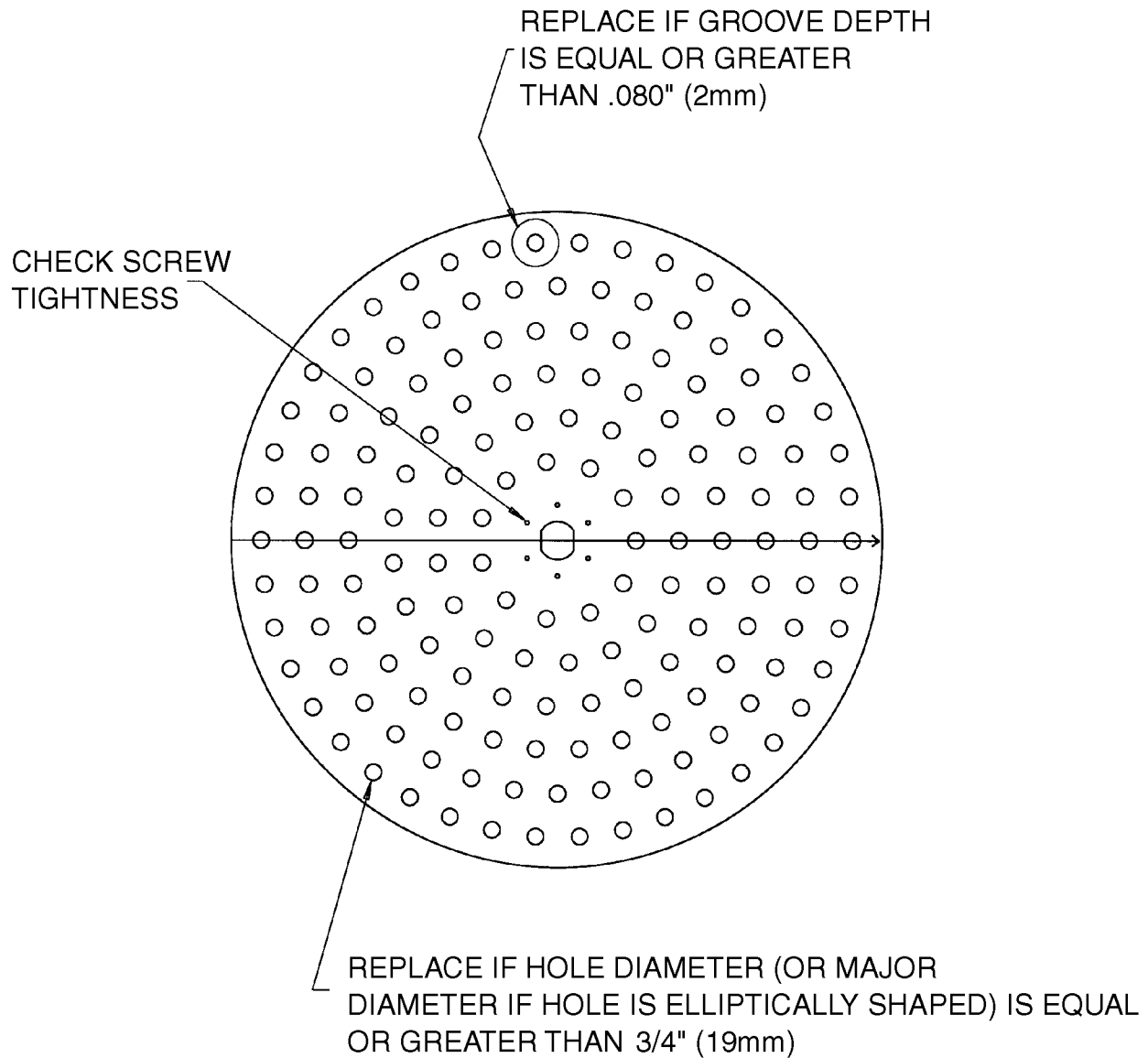
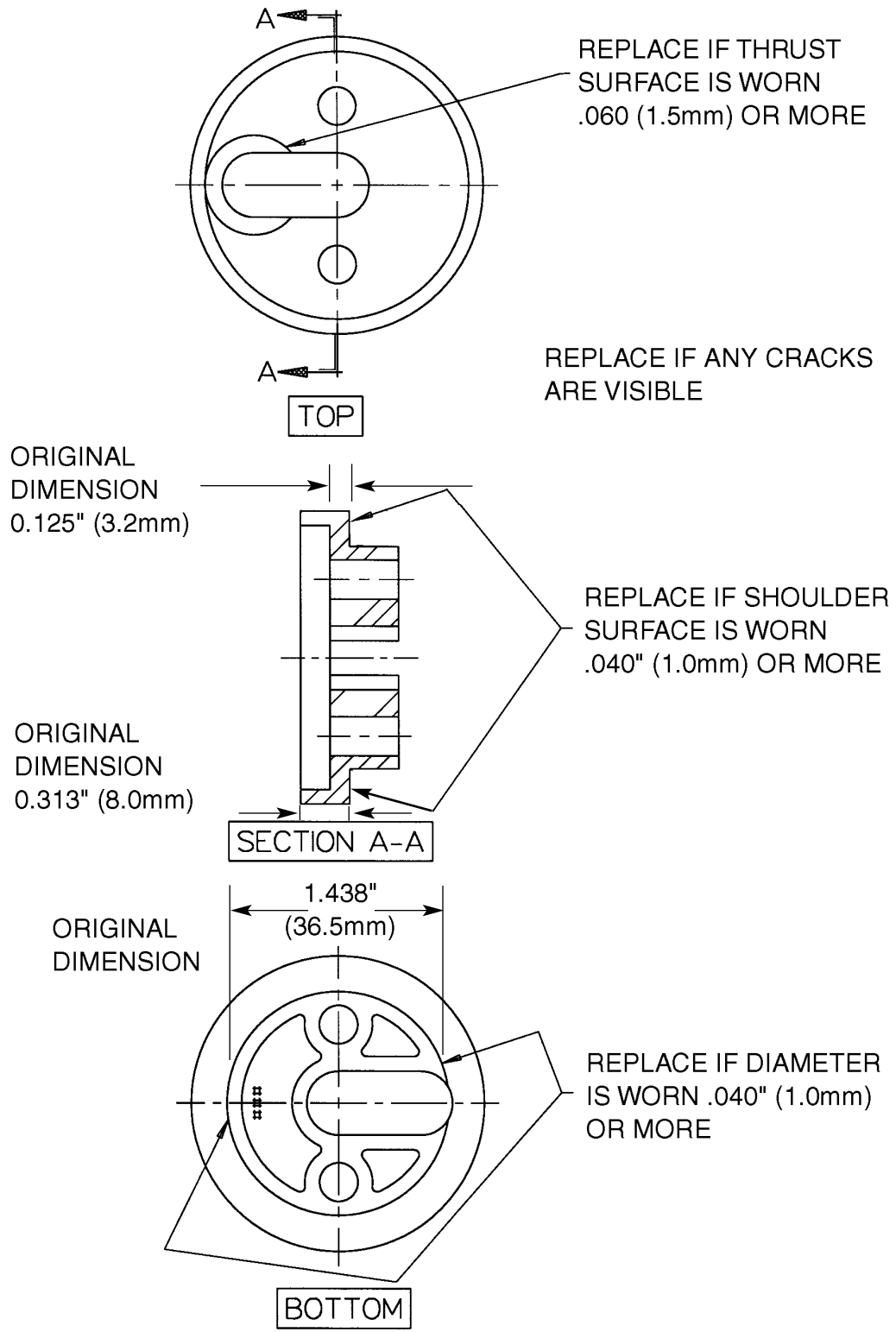

Figure 9 - Drive Plate Inspection Criteria

## 5/8" HOLE DRIVE PLATE

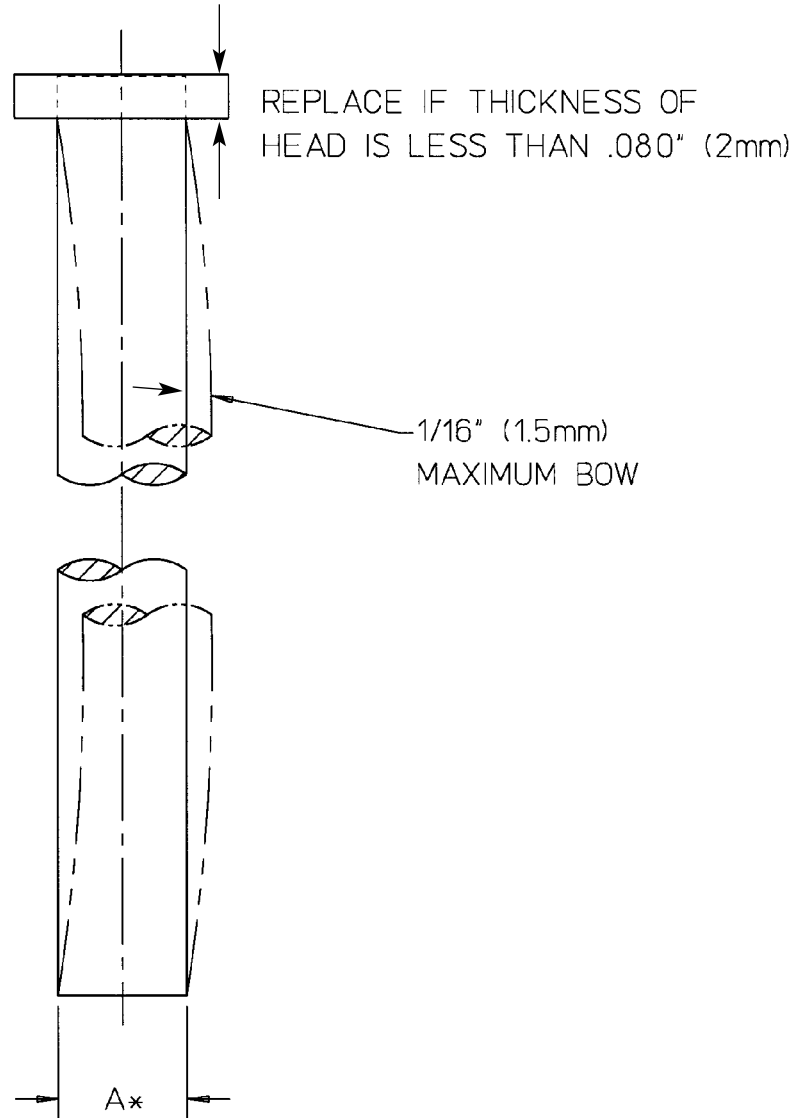

**Figure 10 - Countercrank Inspection Criteria**



## Figure 11 - Whip Rod Inspection Criteria

REPLACE IF ANY VISIBLE FLAT SPOTS ON WHIP ROD  
MEASURE BOW WITH FEELER GAUGE IF WHIP ROD WON'T  
ROLL FREELY ON A FLAT SURFACE



REPLACE IF "A" IS EQUAL  
OR LESS THAN 5/16" (8mm)  
AT ANY POINT ON THE ROD

## Figure 12 - Bearing Sleeve Inspection Criteria

### ▲ Drive Plate Bearing Housing—

Make sure that there is not any apparent scoring inside the bearing sleeve. Measure the ID of the bearing sleeve and refer to the tolerance chart to see if this part can be reinstalled or needs replacing. The lip on the bearing sleeve should be fully seated into the bearing housing.

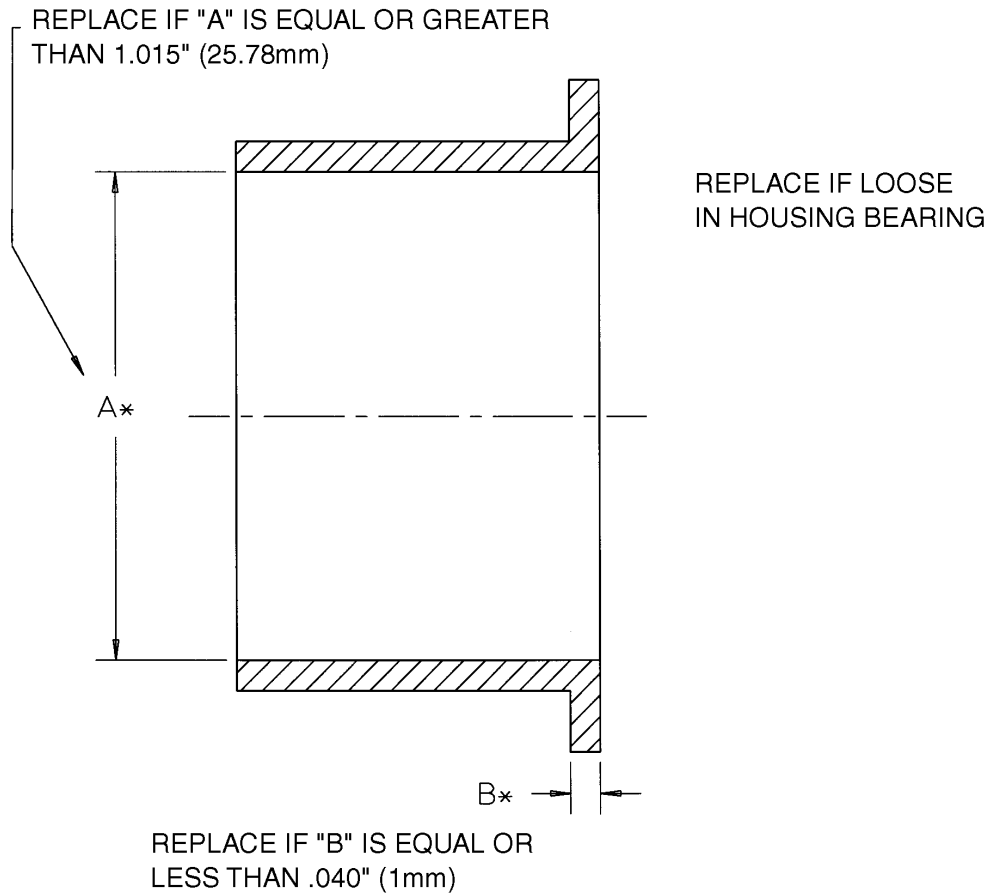

### ▲ Freeze-Up Protection Switch—

Remove the 2 wires that are connected to the freeze-up protection switch. Shut the angle valve off at the evaporator and remove the hose that is connected to the freeze-up protection switch. (**NOTE:** Loosen the hose fitting very slowly because of the possibility of the presence of liquid in the line.) Using a VOM meter, set the meter to the OHM position. Attach the leads to the NC set of contacts on the freeze-up protection switch. Attach the suction hose from your gauge set (blue hose) to the freeze-up protection switch. Attach your charging hose (yellow hose) to a bottle of pressurized gas, preferably nitrogen. When pressure is applied to the switch it will show you the exact pressure of your suction gauge. The freeze-up protection switch should be set to open at 35 psig (240 kPa). If the switch opens before the 35 psig (240 kPa), adjust the switch accordingly.

### ▲ Water Regulating Valve—

You will see 2 valve stems on the inlet and on the outlet side of the solution regulating valve. Using a 0-50 (0-350 kPa) psig gauge with the proper valve stem connection, take a pressure reading on the inlet side of the solution regulating valve. This pressure must be at least 5 psig (35 kPa) and no more than 32 psig (220 kPa). If the pressure on the inlet of the regulator is not within these parameters, the machine is either not getting enough solution and has the possibility of freeze-up or, if it exceeds the pressure, the unit will not be running at the designed capacity. The design flow rates are 65, 130, and 245 gpm (245, 490, and 930 l/min) for the ORE-25, -50, and -100.

**Figure 13 - Tube Insert Inspection Criteria**

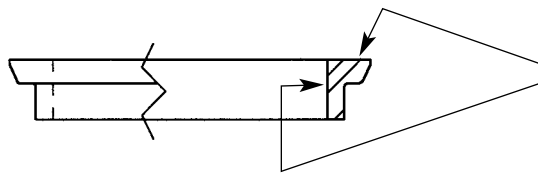

REPLACE IF EITHER SURFACE  
SCORED OR HAS ROUGHNESS  
IS 250  $\mu$  INCH  $R_a$  (6.25  $\mu$  m) OR  
MORE.

REPLACE IF ANY CRACKS  
VISIBLE.

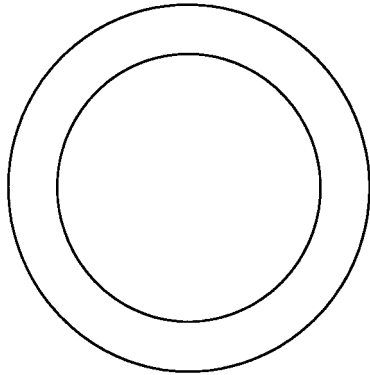

**Figure 14 - Eccentric Crank Inspection Criteria**

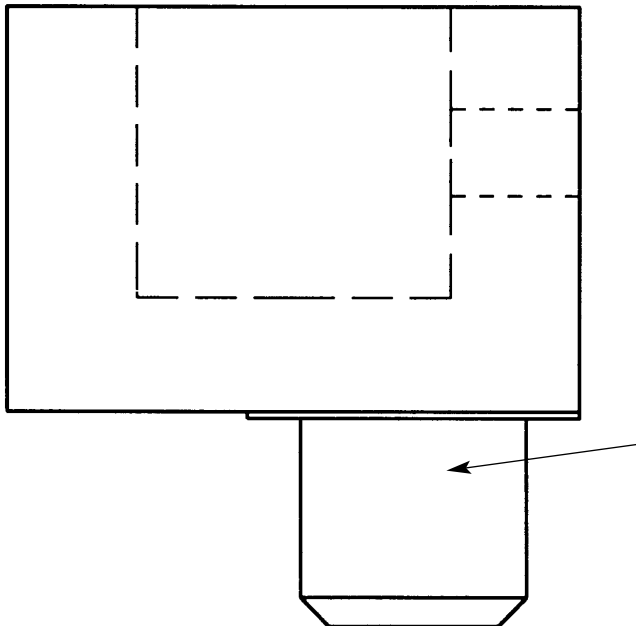

REPLACE IF SURFACE  
ROUGHNESS IS 125  $\mu$  INCH  $R_a$   
(3.1  $\mu$  m) OR MORE

### 8.3 Recommended Drive Component(s) Replacement Schedule

#### ▲ 1,000 hours—

- a. Disassemble drive assembly.
- b. Inspect wear surfaces.
- c. Apply a thin coating of Petroleum-Gel to all surface wearing drive parts.

#### ▲ 8,000 hours—

- a. Possible replacement of countercranks, drive plate, and flange bearing.
- b. Clean ORE inlet strainer.

**NOTE:** The above schedule is based on good glycol solution quality and normal wear. Systems with poor water quality and operational difficulties may require more frequent replacement.

### 8.4 Recommended Monitoring Points

- ▲ Temperatures (°F)
- ▲ Ambient
- ▲ Solution Supply To Process
- ▲ Solution Supply To Evaporator
- ▲ Compressor Discharge
- ▲ Compressor Suction
- ▲ Condenser Liquid Outlet
- ▲ Pressures (psig)
- ▲ Compressor Discharge
- ▲ Condenser Liquid Outlet
- ▲ Drier Core  $\Delta P$
- ▲ Evaporator Suction
- ▲ Main Voltage
- ▲ AMPS
- ▲ Compressor Motor
- ▲ Evaporator Drive Motor
- ▲ Evaporator Solution Pump Motor
- ▲ Evaporator Slurry Pump Motor

## SECTION 9.0 - RECOMMENDED SPARE PARTS

### 9.0 Recommended Spare Parts

The following list consists of specialty-type or hard-to-find parts, while most all other parts can be purchased locally. See Figure 4.

#### 9.1 ORE Common Parts:

Description	Recommended Qty.	PMC Part #
Oil Return Solenoid Valve (R-22)	1	9840018
Oil Return Solenoid Valve (R-717)	1	9841307
Whip Rod	(ORE-25 - 20) (ORE-50 - 40) (ORE-100 - 80)	8850044
Counter Crank - Right Hand	(ORE-25 - 20) (ORE-50 - 40) (ORE-100 - 80)	9842676
Counter Crank - Left Hand	(ORE-25 - 20) (ORE-50 - 40) (ORE-100 - 80)	9842677
Thrust Washer (manufactured before 10/1/99)	(ORE-25 - 20) (ORE-50 - 40) (ORE-100 - 80)	9840477
Full Ice Sensor (temperature controller)	1	9840492
Full Ice Sensor (RTD)	1	9840550
Liquid Level Valve - Heater & Cord	1	9840551

#### 9.2 ORE-25 Parts:

Description	Recommended Qty.	PMC Part #
Drive Plate	1	9840975
Drive Motor Shaft Seal	1	9823991
Housing Bearing	1	9840455
Liquid Level Valve Kit (LMC-MVE-20)	1	9840557
Liquid Level Valve Kit (LMC-MVE-26)	1	9840558
Liquid Level Valve Kit (LMC-MVE-34)	1	9840559
Liquid Level Valve (LMC-AAE-30)	1	9842708
Power Head & Heater - MVE (R-22)	1	9840556
Power Head & Heater - MVE, VVE, & WVE (R-22)	1	9840564
Power Head & Heater - (R-717 only)	1	9842704

#### 9.3 ORE-50 Parts:

Description	Recommended Qty.	PMC Part #
Drive Plate	1	9842626
Drive Plate Assembly (plate, housing bearing, bearing sleeve)	1	9842640
Drive Motor Shaft Seal	1	9840339
Housing Bearing	1	9842349
Liquid Level Valve Kit (LMC-MVE-42)	1	9840560
Liquid Level Valve Kit (LMC-MVE-52)	1	9840561
Liquid Level Valve Kit (LMC-MVE-70)	1	9840562
Liquid Level Valve Kit (LMC-AAE-50)	1	9842707
Power Head & Heater (LMC-MVE, VVE) (R-22 only)	1	9840564
Power Head & Heater (R-717 only)	1	9842704
Crank Electric Assembly	1	9842862

## 9.4 ORE-100 Parts:

Description	Recommended Qty.	PMC Part #
Drive Plate	1	9842620
Drive Plate Assembly (plate, housing bearing, bearing sleeve)	1	9842872
Drive Motor Shaft Seal	1	9840666
Housing Bearing	1	9842349
Bearing Sleeve	1	9840320
Liquid Level Valve Kit (LMC-VVE-100)	1	9840562
Liquid Level Valve Kit (LMC-AAE-100)	1	9842705
Liquid Level Valve Kit (LMC-WVE-135)	1	9840563
Power Head & Heater (R-22 only)	1	9840564
Power Head & Heater (R-717 only)	1	9842704
Crank Electric Assembly	1	9842681

## SECTION 10.0 - TROUBLESHOOTING FAILURES

### 10.1 Troubleshooting Chart 1: Low-Pressure Evaporator - Freeze-Up Protection Alarm

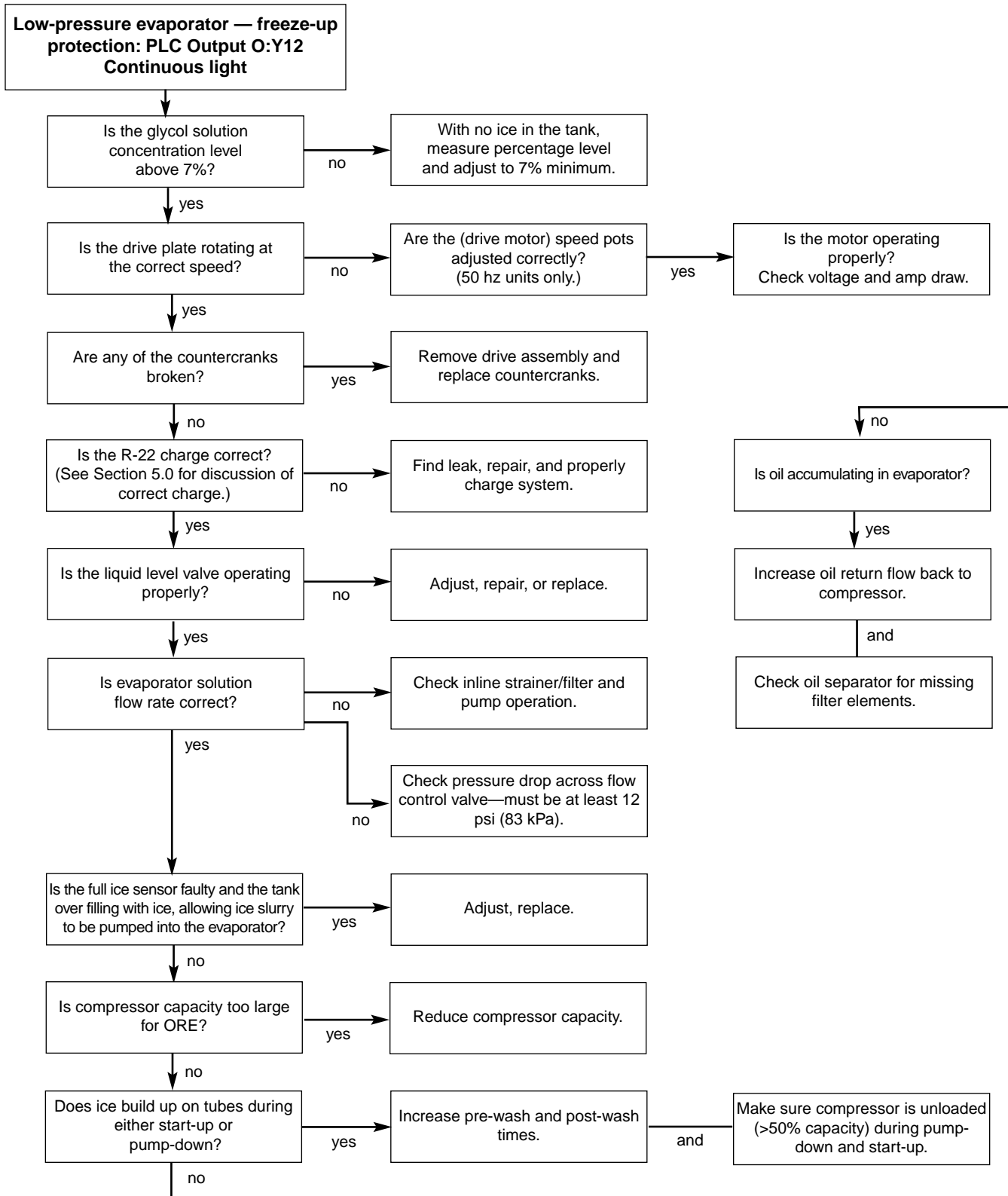

## 10.2 Troubleshooting Chart 2: Unit Fails on Vent Switch

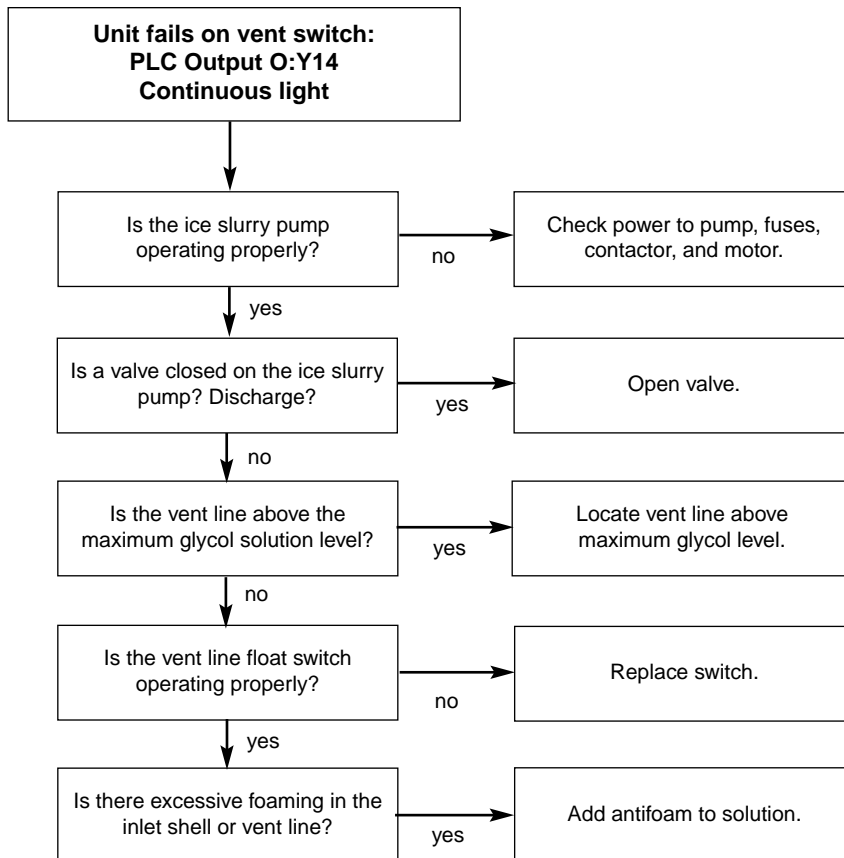

### 10.3 Troubleshooting Chart 3: Unit Will Not Start

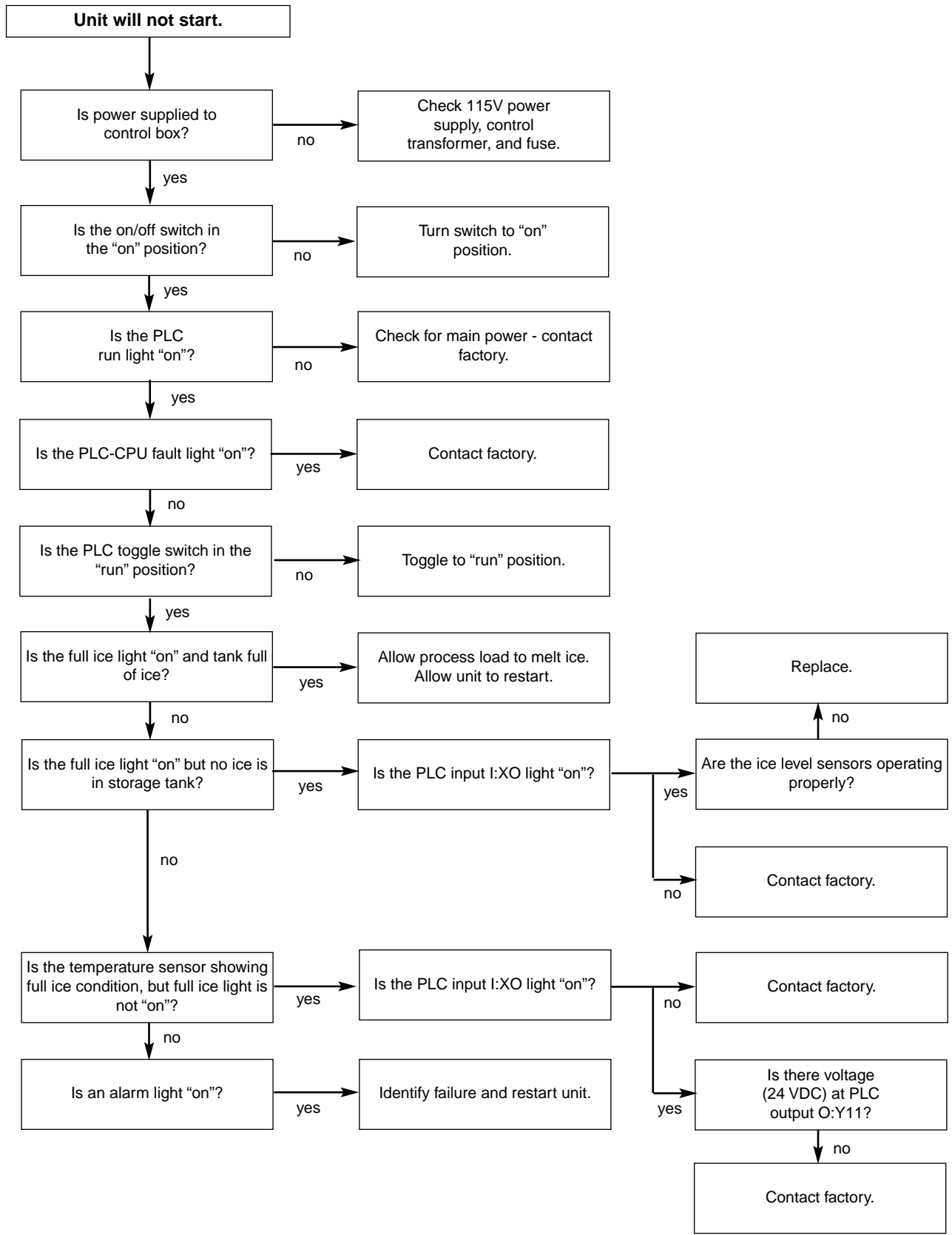

## 10.4 Troubleshooting Chart 4: Compressor Operates with High Discharge Pressure

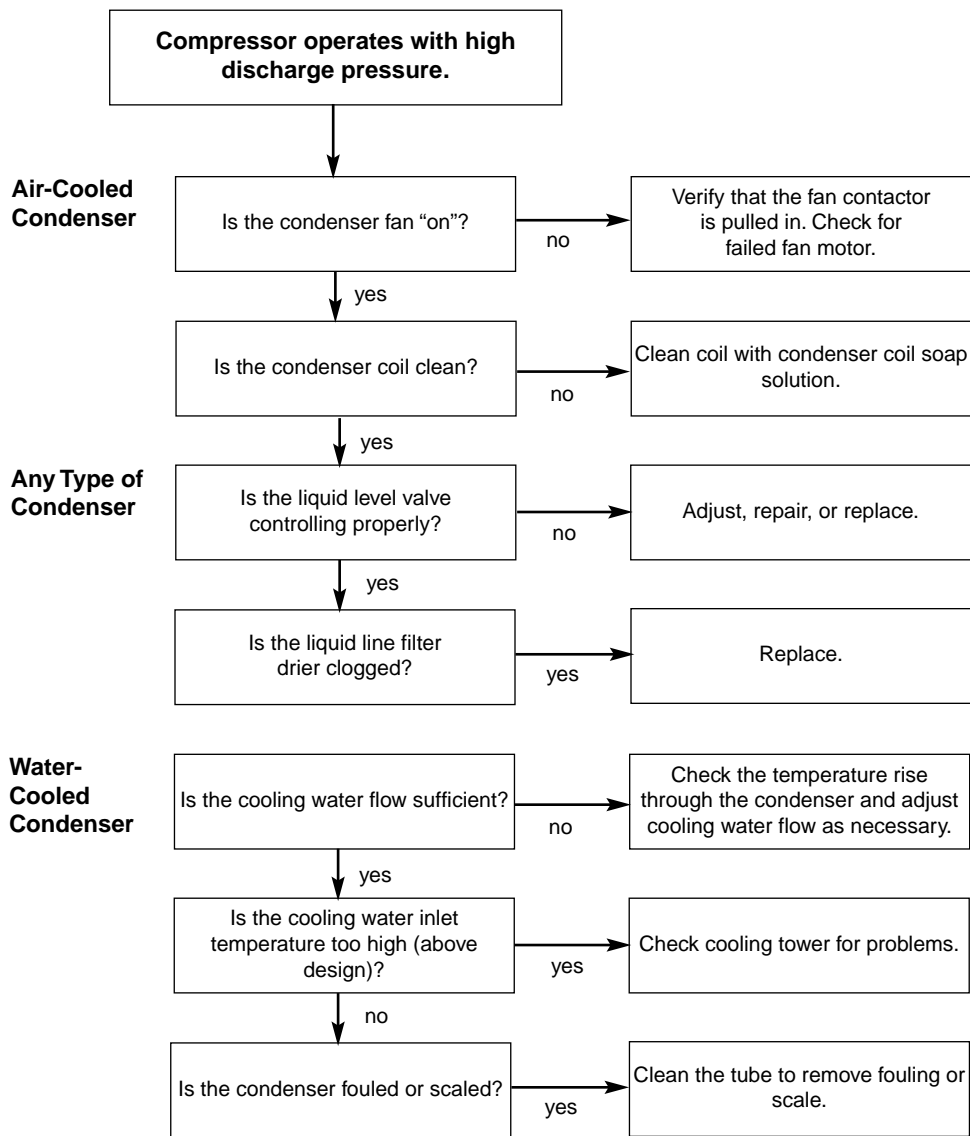

## 10.5 Troubleshooting Chart 5: Compressor Operates with Low Suction Pressure

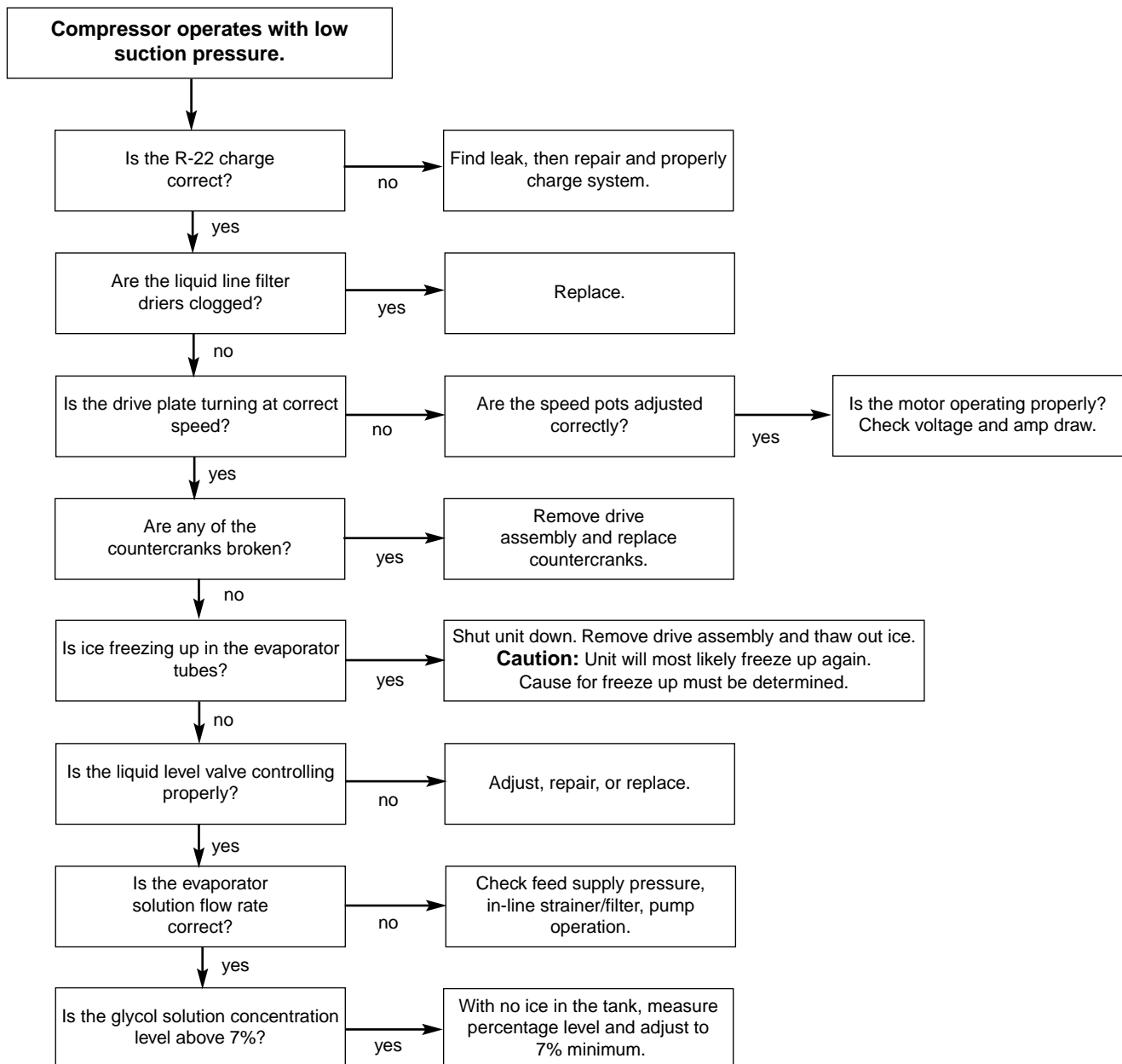

## 10.6 Troubleshooting Chart 6: System Will Not Make Ice

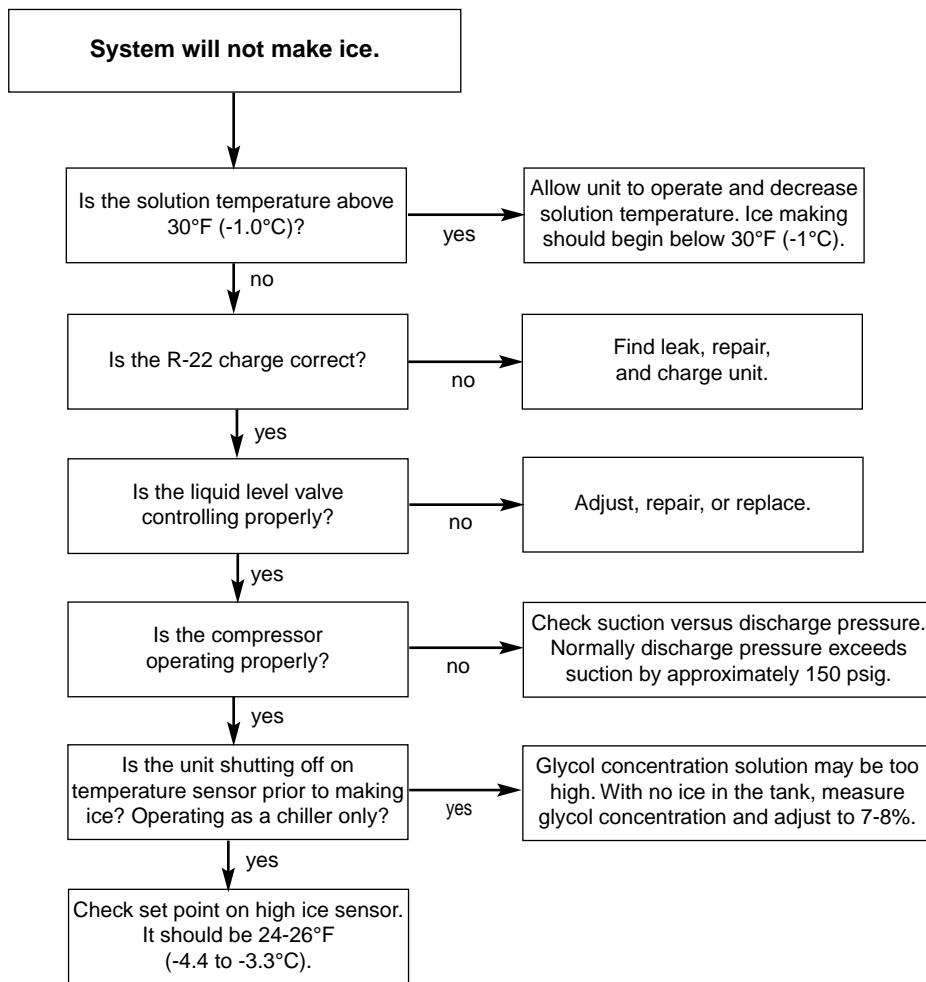

## 10.7 Troubleshooting Chart 7: Compressor Fails on Motor Overload

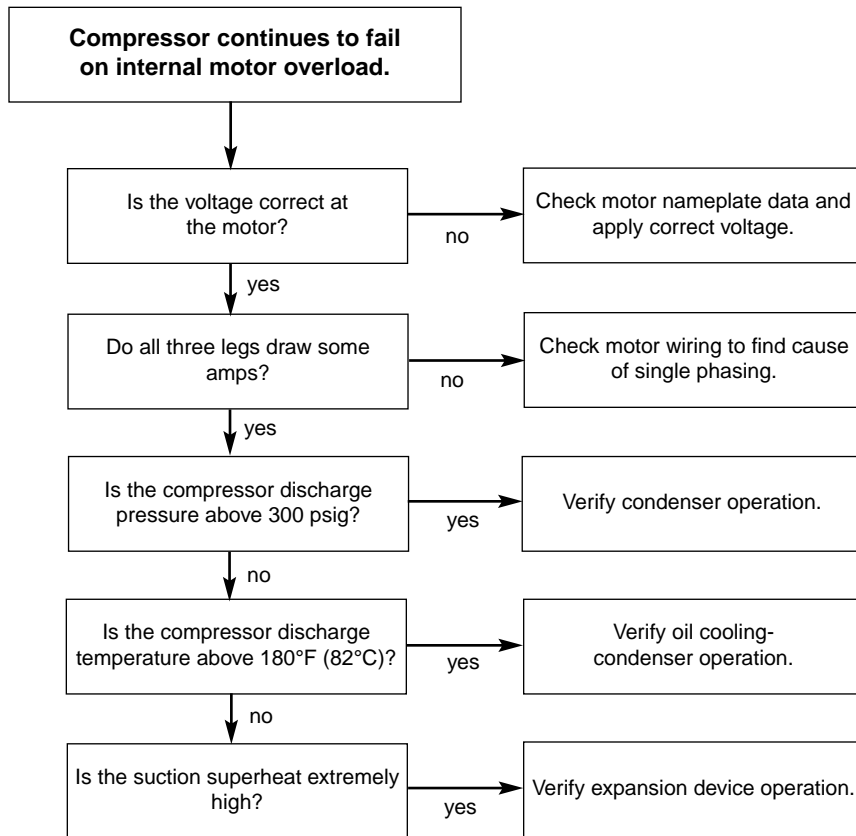

## 10.8 Troubleshooting Chart 8: System Will Not Cool Building/Process Load

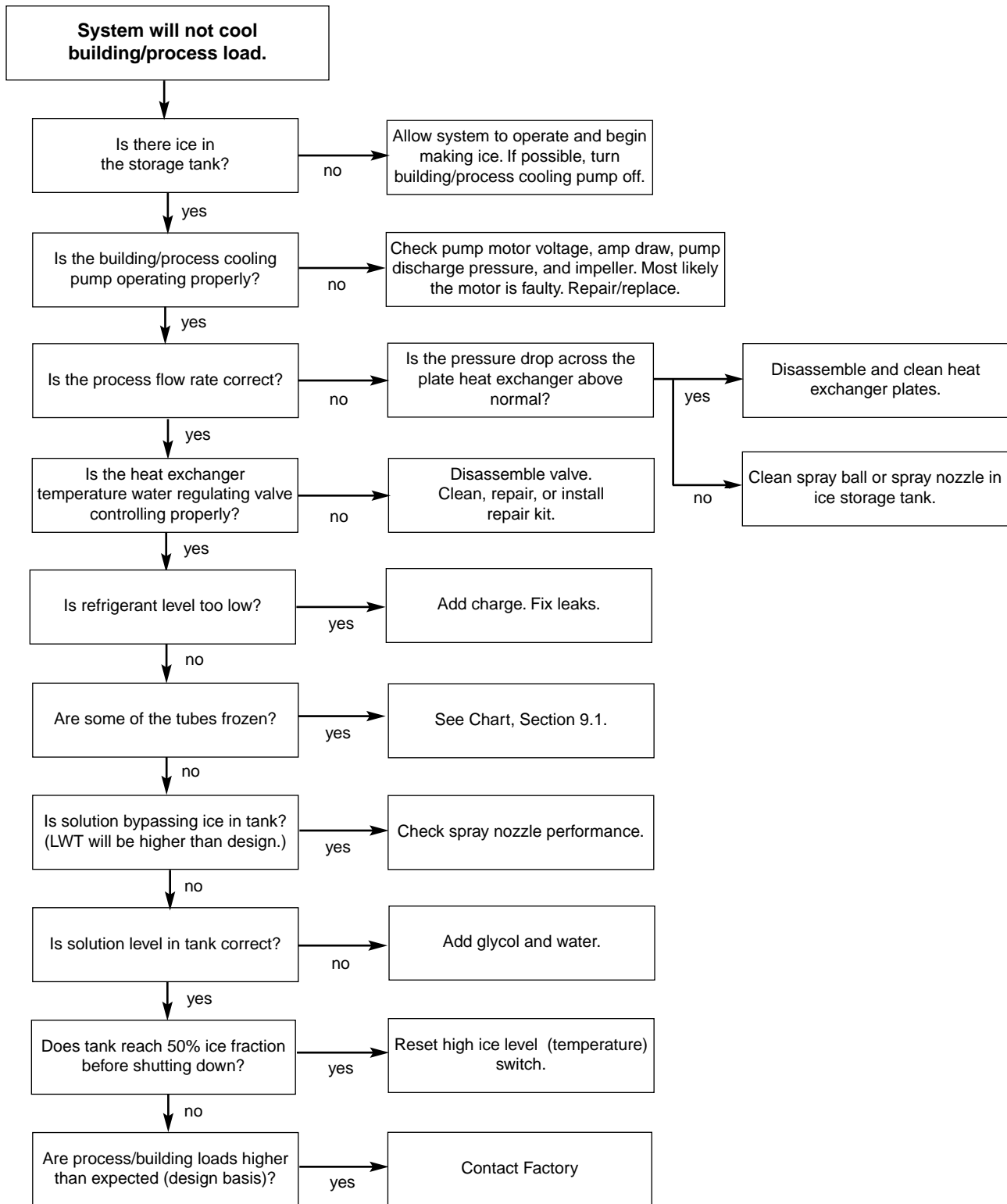

## 10.9 Troubleshooting Chart 9: Excessive Evaporator Shell Vibration

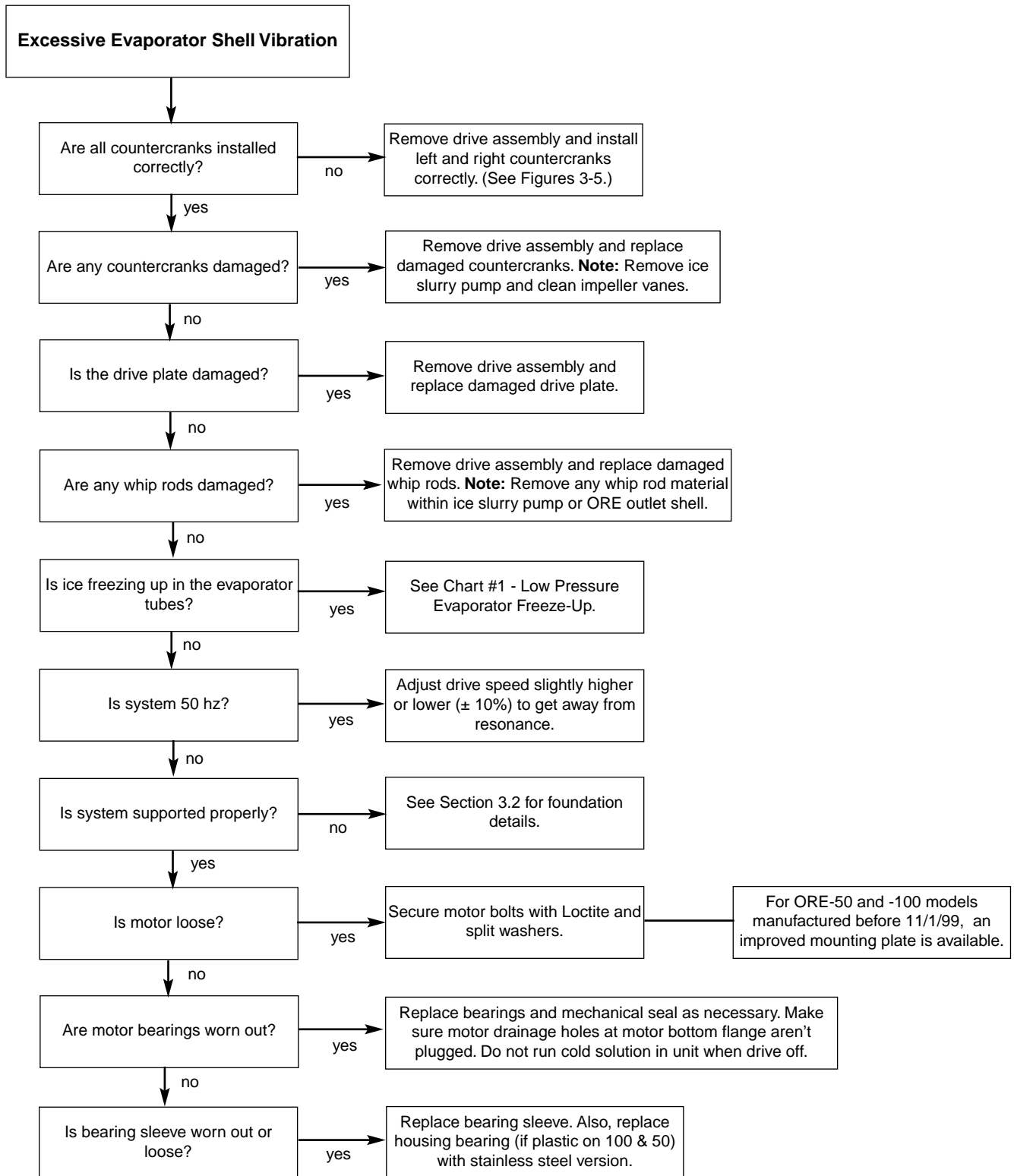

## 10.10 Troubleshooting Chart 10: Compressor Fails on Low Oil Pressure

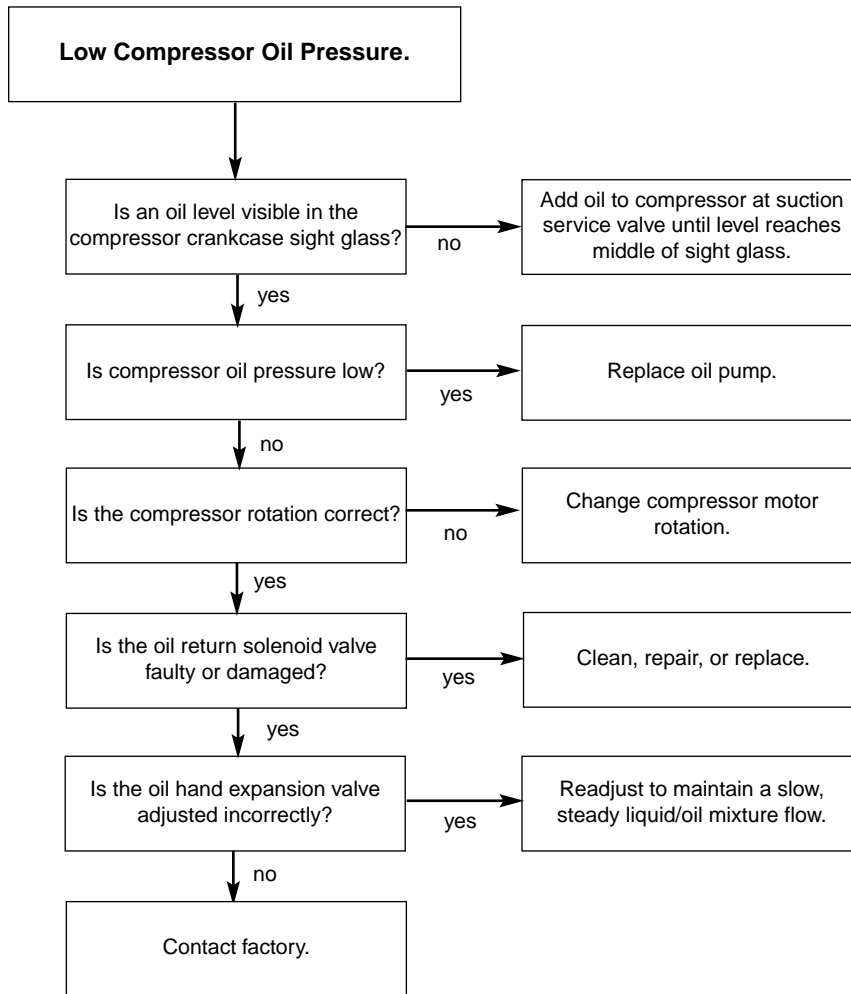

## 10.11 Troubleshooting Chart 11: Excessive Wear



## SECTION 11.0 - START-UP REQUIREMENTS

### 11.1 MaximICE® Start-Up Request Form

Prior to requesting start-up, verify that all the following items are complete. Only PMC-qualified start-up personnel shall be authorized for start-up. Unauthorized start-up of equipment will result in immediate void of warranty.

Purchaser: \_\_\_\_\_  
Address: \_\_\_\_\_  
Contact Person: \_\_\_\_\_  
Telephone No.: \_\_\_\_\_  
Facsimile No.: \_\_\_\_\_  
Unit Model: \_\_\_\_\_  
Unit Serial No.: \_\_\_\_\_  
Installation Location: \_\_\_\_\_  
Address: \_\_\_\_\_

### 11.2 MaximICE Evaporator Unit

- ▲ Equipment must be inspected for any damage that may have occurred during shipping. If damage is found, a claim should be made against the trucking company.
- ▲ Check the packing slip or bill of lading to ensure that all accessory parts called for in the sales order are included.
- ▲ The unit must be level to within  $\frac{1}{8}$ " (3 mm) over the length and width.
- ▲ All remote piping must be cleaned.
- ▲ All pumps must be secured (vertical shaft pumps should be properly protected and aligned).
- ▲ Control wiring connected between the ORE and the condensing unit.
- ▲ All shipping material removed from the inlet shell and the bottom of the evaporator.

### 11.3 Refrigerant Piping For Remote Condenser Systems

- ▲ All remote refrigerant piping must be installed in accordance with the approved piping practice (ANSI/AMSE).
- ▲ All piping must be properly supported.
- ▲ Pressure test complete system for leak (including PMC equipment).
- ▲ Complete system evacuated.
- ▲ Full refrigerant charge (provided by others) to be on-site at start-up.

## 11.4 Water Piping

- ▲ (If required) strainer installed.
- ▲ Check for water leaks.
- ▲ All flow controls checked and calibrated.
- ▲ (Water-cooled condenser) install water regulating valve on the condenser outlet.
- ▲ (Oil cooler) water piping installed.
- ▲ Check water loop design control.
- ▲ Freeze protection installed on all applicable piping.

## 11.5 Electrical

- ▲ Adequate power supply to unit.
- ▲ Three-phase and control wiring completed to the unit and any remote equipment.
- ▲ All wiring and grounding conforms to national, state, and local electrical codes.
- ▲ (High voltage systems) megohmmeter test main wiring circuit complete to compressor motor.
- ▲ All wire is copper (no aluminum wiring).

## 11.6 Installing Contractor Shall Furnish The Following

- ▲ All materials and labor necessary to assist in the installation/start-up.
- ▲ A refrigeration service mechanic to assist PMC start-up personnel during start-up for necessary training in the operation of the unit. This training is essential in performing in-warranty labor incumbent upon contractor and/or end user.

## 11.7 Compressor Package

- ▲ Check compressor/motor alignment and align as necessary to within  $\pm.004$ " (0.1 mm) angular/parallel.
- ▲ Check oil pump/motor alignment and align as necessary to within  $\pm.004$ " (0.1 mm) angular/parallel.

## **SECTION 12.0 - WIRING DIAGRAMS**

### **12.1 Schematic Wiring Diagram (50 Hz), Part No. 9841026**

## 12.2 Schematic Wiring Diagram (60 hz), Part No. 9823978

# SECTION 13.0 - MUELLER MaximICE LIQUID ICE EVAPORATOR EQUIPMENT SPECIFICATIONS

## 13.1 Model ORE-25 Flooded Refrigerant Feed, Pumped Slush Discharge, Drawing No. 8200139

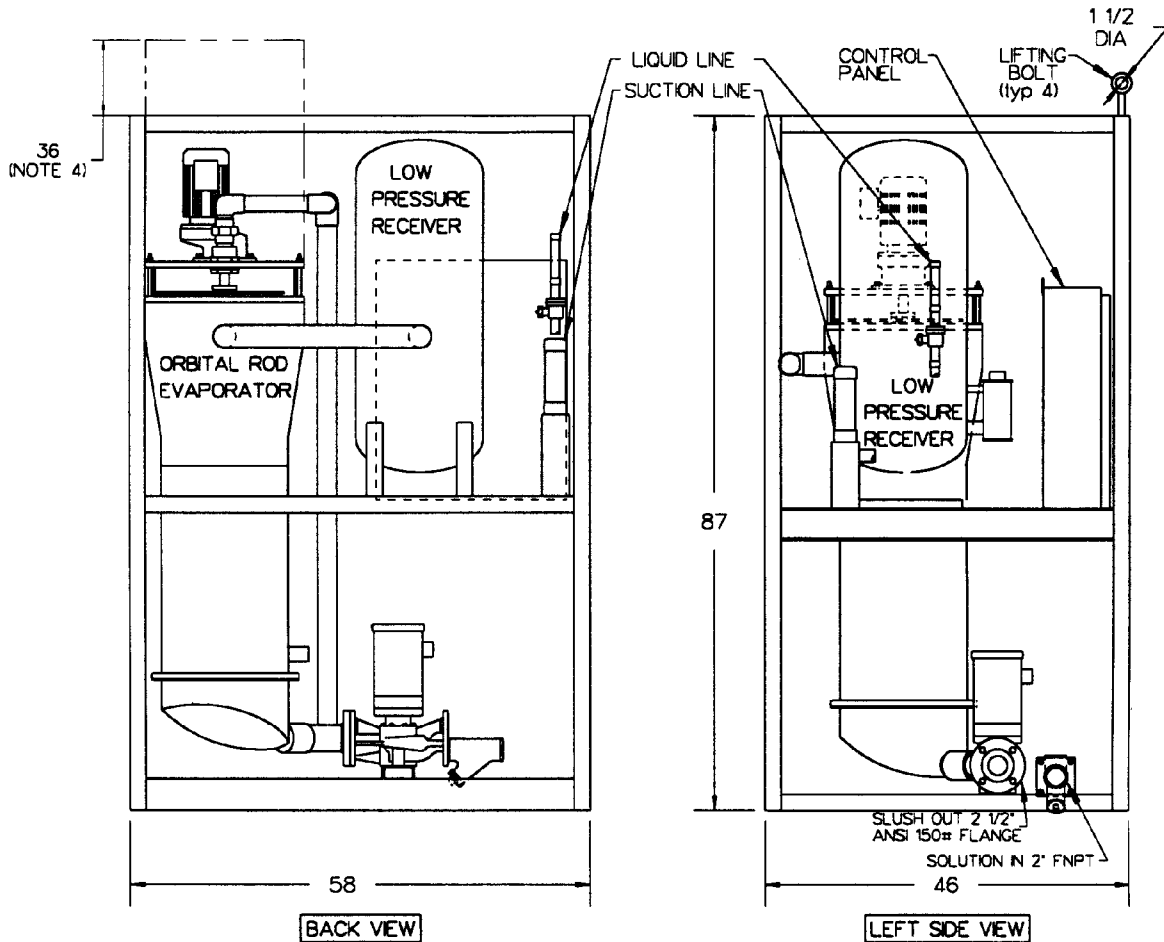

SHIP WEIGHT (lbs)	DESIGN WEIGHT (lbs)	REFRIGERANT	REFRIGERANT CHARGE (lbs)	CONNECTIONS		SOLUTION FEED (IN)		SLUSH PUMP (OUT)		
				SUCTION	LIQUID	FLOW RATE	INLET PRESS. REQ'D	HP	DISCHARGE HEAD 50-HZ	60-HZ
2,500	2,750	R-22	250	2 5/8" ODS	1 1/8" ODS	65 (gpm)	5-30 (psig)	3/4	14 FT	22 FT
		R-717	125	2" SCH 40	3/4" SCH 80			2	31 FT	49 FT

### NOTES:

- All dimensions are in inches unless specified otherwise.
- PMC reserves the right to make product design changes which may alter the weights and or dimensions without prior notification.
- Three foot (3') minimum service clearance is required on all sides of assembly.
- Three feet (3') minimum clearance above ORE is required for removal of whip rods.
- Single point electrical connection through side of control panel.
- Insulated paneling adds 5" to length, 5" to width, 2 1/2" to height.

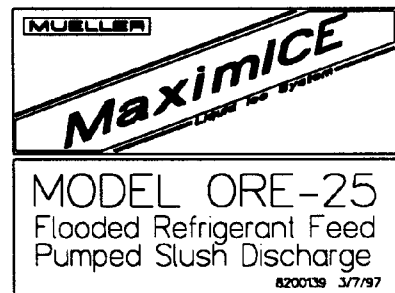

# 13.2 Model ORE-25 Flooded Refrigerant Feed, Pumped Slush Discharge Schematic, Drawing No. 8200146

## SINGLE PHASE ORE-25 TYPICAL WIRING SCHEMATIC

\*Single compressor condensing unit wiring shown. See unit wiring diagram for multiple condensing units and optional items.

11	I	Remote Start - Provide normally open dry contacts to start unit from remote location. With unit toggle switch turned to "Auto", unit will start upon contact closure.
12	I	
4	I	Load Pump Operation - Provide normally open dry contacts for monitoring of pump operation (either auxiliary contacts or from EMS). Contacts close upon pump start.
17	I	
4	I	Solution Pump Operation - Provide normally open dry contacts for monitoring of pump operation (either auxiliary contacts or from EMS). Contacts close upon pump start.
40	I	
4	I	Condensing Unit Pumpdown Low Pressure Switch - Provide normally closed dry contacts. Contacts open when suction pressure drops to 5 psig, condensing unit shuts down.
9	I	
4	I	Condensing Unit Alarm 1- Provide normally closed dry contacts. Contacts open upon condensing unit alarm condition, condensing unit shuts down.
10	I	
4	I	Condensing Unit Alarm 2 * Jumper in control box. (OPTIONAL)
41	I	
4	I	Remote temperature switch.* Wired to remote ice level inventory sensor. Contacts close on full ice condition (predetermined temperature setting). (OPTIONAL)
15	I	
2	O	Condensing Unit Start - 24VAC contacts close to start condensing unit.
29	O	
2	O	Compressor Unloading, Step 1 - 24VAC contacts close to unload compressor.
31	O	
2	O	Compressor Unloading, Step 2 * 24VAC contacts close to unload compressor.
32	O	
35	O	Remote Alarm - Dry contacts close upon alarm condition for remote alarm indication.
36	O	
37	O	Remote Solution Pump Start - Dry contacts close to start solution pump.
38	O	
+		

I = INPUT TO MaximICE PLC.  
O = OUTPUT FROM MaximICE PLC.

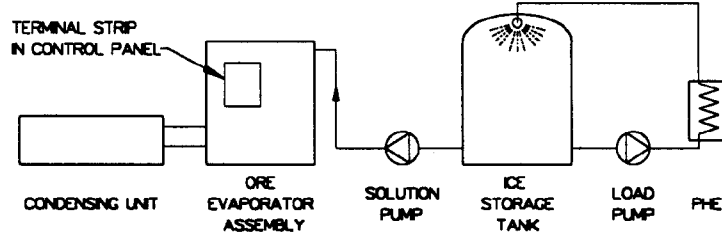

## THREE PHASE POWER

CUSTOMER SUPPLIED  
3 PHASE WITH GROUND

VOLTAGE	DRIVE MOTOR HP	MOTOR FLA (EAL)	SLUSH PUMP HP / FLA	MIN. CIRCUIT AMPACITY	MAXIMUM OVERCURRENT PROTECTION
200/3/50	3/4	3.5	1/2 / 2.6	7.7	11.2
			1 / 3.6	8.8	12.4
208/3/60	3/4	3.4	3/4 / 2.7	7.7	11.1
			2 / 5.9	11.5	17.4
230/3/60	3/4	3.05	3/4 / 2.6	7.1	10.1
380/3/50	3/4	1.75	2 / 5.6	10.7	16.3
			1/2 / 1.2	4.7	6.5
380/3/60	3/4	1.85	1 / 1.8	5.3	7.1
			3/4 / 1.6	5.2	7.1
460/3/60	3/4	1.53	2 / 3	8.9	9.9
			3/4 / 1.3	4.3	5.8
			2 / 2.8	6.1	8.9

**MUELLER**

MaximICE

Liquid Ice System

---

MODEL ORE-25

Flooded Refrigerant Feed  
Pumped Slush Discharge

8200146 3/7/97

### 13.3 Model ORE-25 Flooded Refrigerant Feed, Gravity Slush Discharge, Drawing No. 8200153

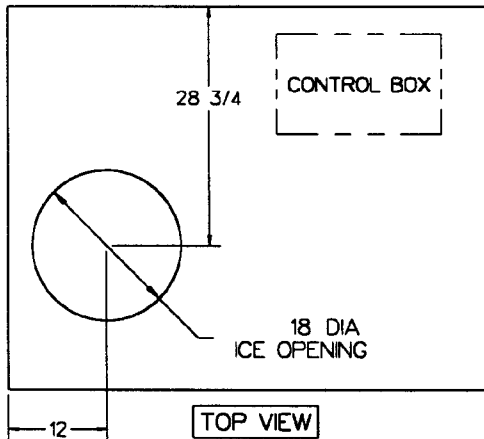
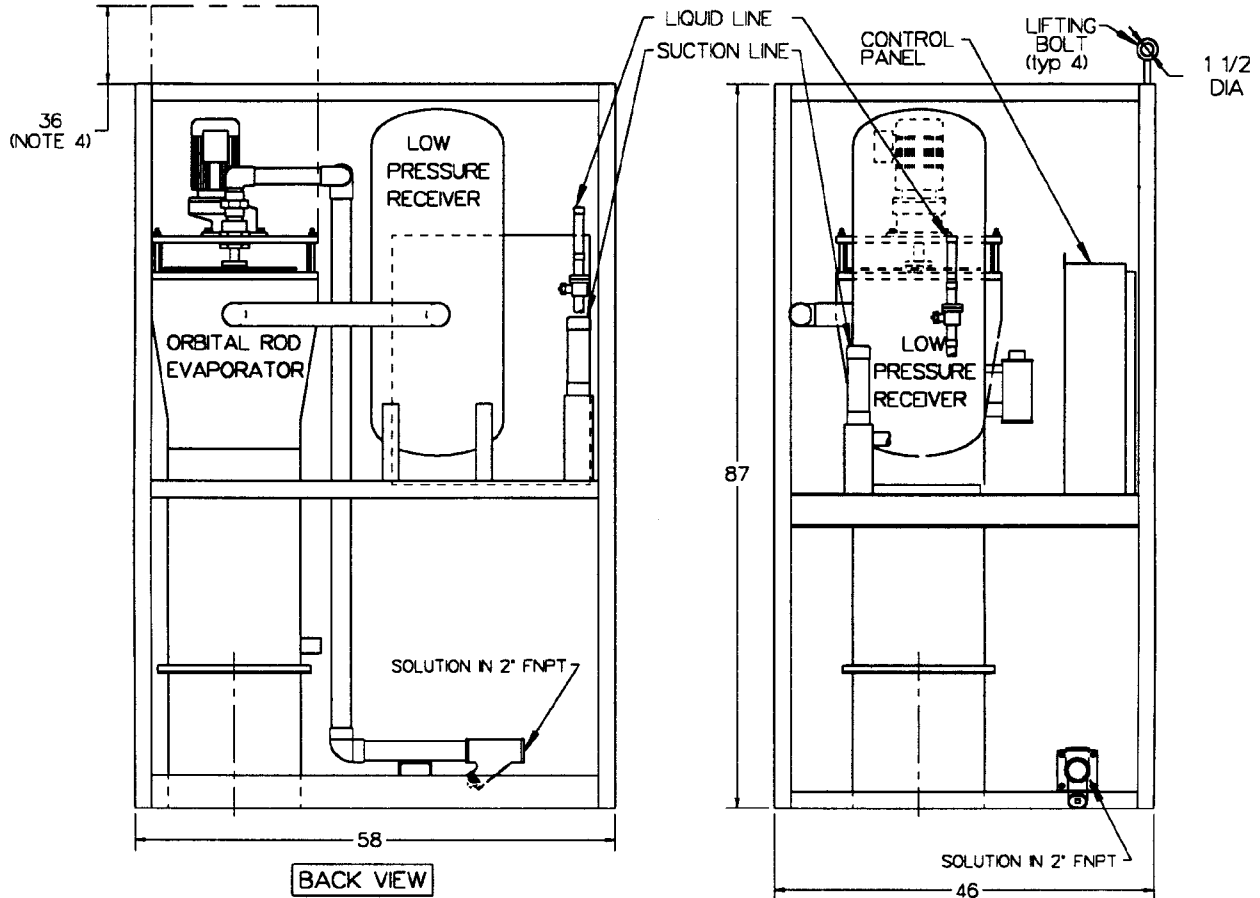

**NOTES:**

1. All dimensions are in inches unless specified otherwise.
2. PMC reserves the right to make product design changes which may alter the weights and or dimensions without prior notification.
3. Three foot (3') minimum service clearance is required on all sides of assembly.
4. Three feet (3') minimum clearance above ORE is required for removal of whip rods.
5. Single point electrical connection through side of control panel.
6. Insulated paneling adds 5" to length, 5" to width, 2 1/2" to height.



SHIP WEIGHT (lbs)	DESIGN WEIGHT (lbs)	REFRIGERANT	REFRIGERANT CHARGE (lbs)	CONNECTIONS		SOLUTION FEED (IN)	
				SUCTION	LIQUID	FLOW RATE	INLET PRESS. RECD
2.450	2.700	R-22	250	2 5/8" ODS	1 1/8" ODS	65 (gpm)	5-30 (psig)
		R-717	125	2" SCH 40	3/4" SCH 80		

**MODEL ORE-25**  
Flooded Refrigerant Feed  
Gravity Slush Discharge

8200153 3/7/97

# 13.4 Model ORE-25 Flooded Refrigerant Feed, Gravity Slush Discharge Schematic, Drawing No. 8200160

## SINGLE PHASE ORE-25 TYPICAL WIRING SCHEMATIC

\*Single compressor  
condensing unit wiring shown.  
See unit wiring diagram  
for multiple condensing units  
and optional items.

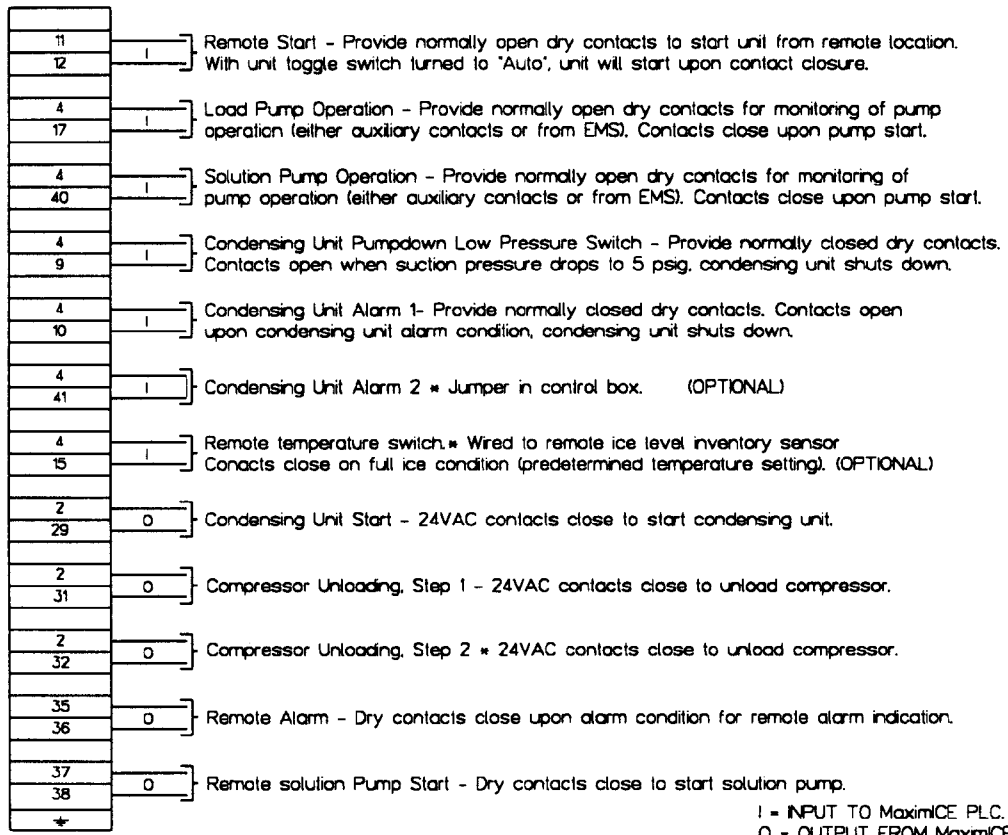

I = INPUT TO MaximICE PLC.  
O = OUTPUT FROM MaximICE PLC.

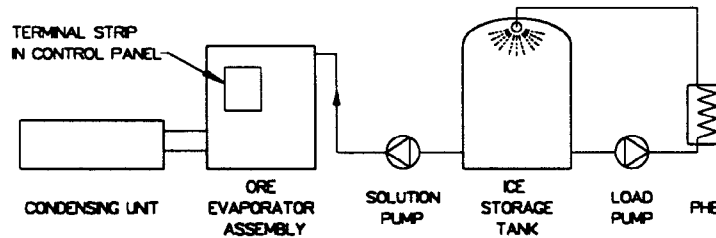

## THREE PHASE POWER

CUSTOMER SUPPLIED  
3 PHASE WITH GROUND

VOLTAGE	DRIVE MOTOR HP	MOTOR FLA (EAL)	MIN. CIRCUIT AMPACITY	MAXIMUM OVERCURRENT PROTECTION
200/3/50	3/4	3.5	5.1	8.6
208/3/60		3.4	5	8.4
230/3/60		3.05	4.5	7.5
380/3/50		1.75	3.5	5.3
380/3/60		1.85	3.6	5.5
460/3/60		1.53	3.0	4.5



**MODEL ORE-25**  
Flooded Refrigerant Feed  
Gravity Slush Discharge

8200160 3/10/97

### 13.5 Model ORE-50 Flooded Refrigerant Feed, Pumped Slush Discharge, Drawing No. 8200140

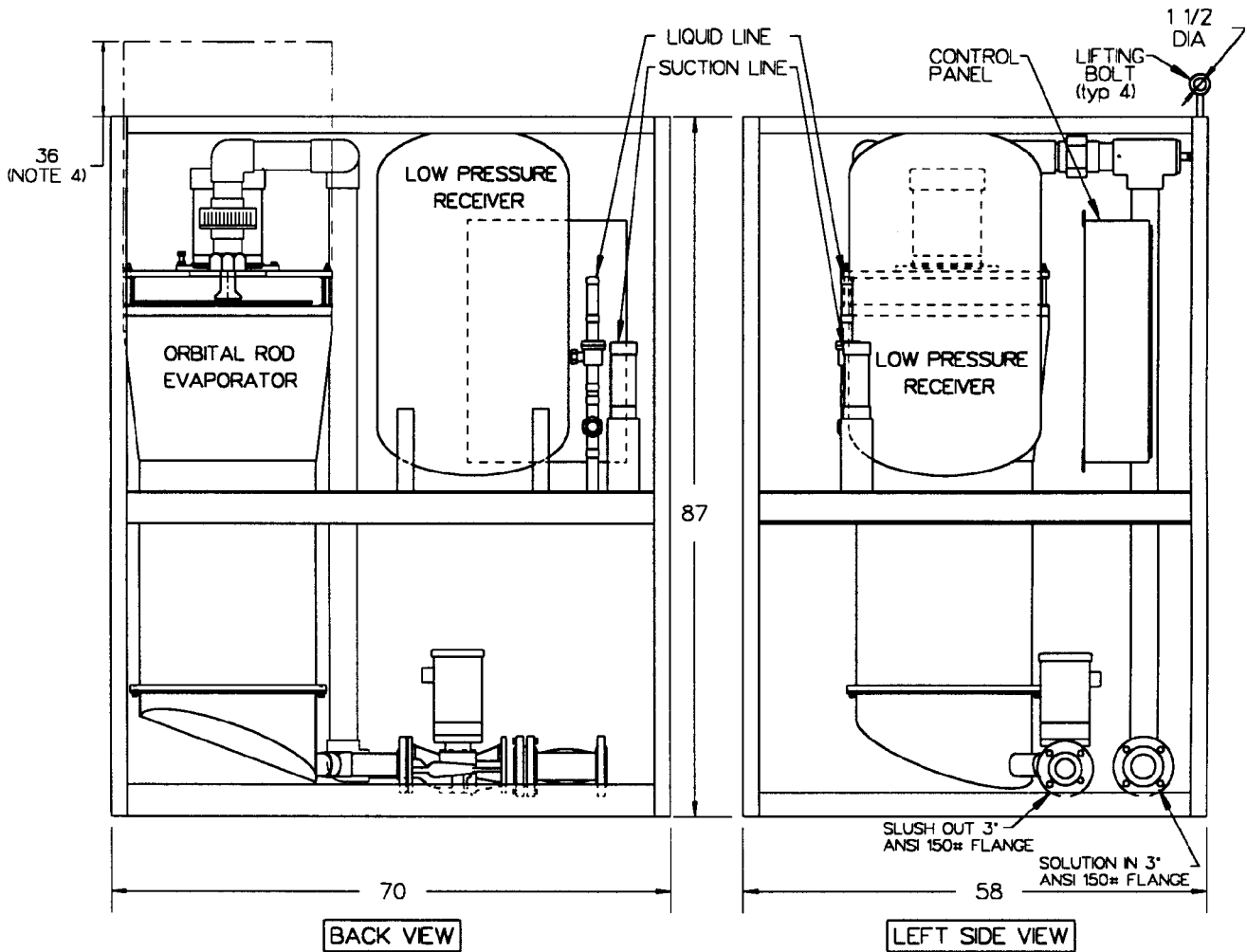

SHIP WEIGHT (lbs)	DESIGN WEIGHT (lbs)	REFRIGERANT	REFRIGERANT CHARGE (lbs)	CONNECTIONS		SOLUTION FEED (IN)		SLUSH PUMP (OUT)		
				SUCTION	LIQUID	FLOW RATE	INLET PRESS. REQ'D	HP	DISCHARGE HEAD 50HZ	60HZ
3,900	4,400	R-22	600	3 1/8" ODS	1 3/8" ODS	135 (gpm)	5-30 (psig)	2	15 FT	29 FT
		R-717	300	2 1/2" SCH 40	1" SCH 80			3	21 FT	47 FT

**NOTES:**

1. All dimensions are in inches unless specified otherwise.
2. PMC reserves the right to make product design changes which may alter the weights and or dimensions without prior notification.
3. Three foot (3') minimum service clearance is required on all sides of assembly.
4. Three feet (3') minimum clearance above ORE is required for removal of whip rods.
5. Single point electrical connection through side of control panel.
6. Insulated paneling adds 5" to length, 5" to width, 2 1/2' to height.

**MUELLER**

MaximICE

LIQUID ICE SYSTEM

---

MODEL ORE-50

Flooded Refrigerant Feed  
Pumped Slush Discharge

8200140 3/10/97

# 13.6 Model ORE-50 Flooded Refrigerant Feed, Pumped Slush Discharge Schematic, Drawing No. 8200147

## SINGLE PHASE ORE-50 TYPICAL WIRING SCHEMATIC

\*Dual compressor condensing unit wiring shown. See unit wiring diagram for single compressor condensing unit and optional items.

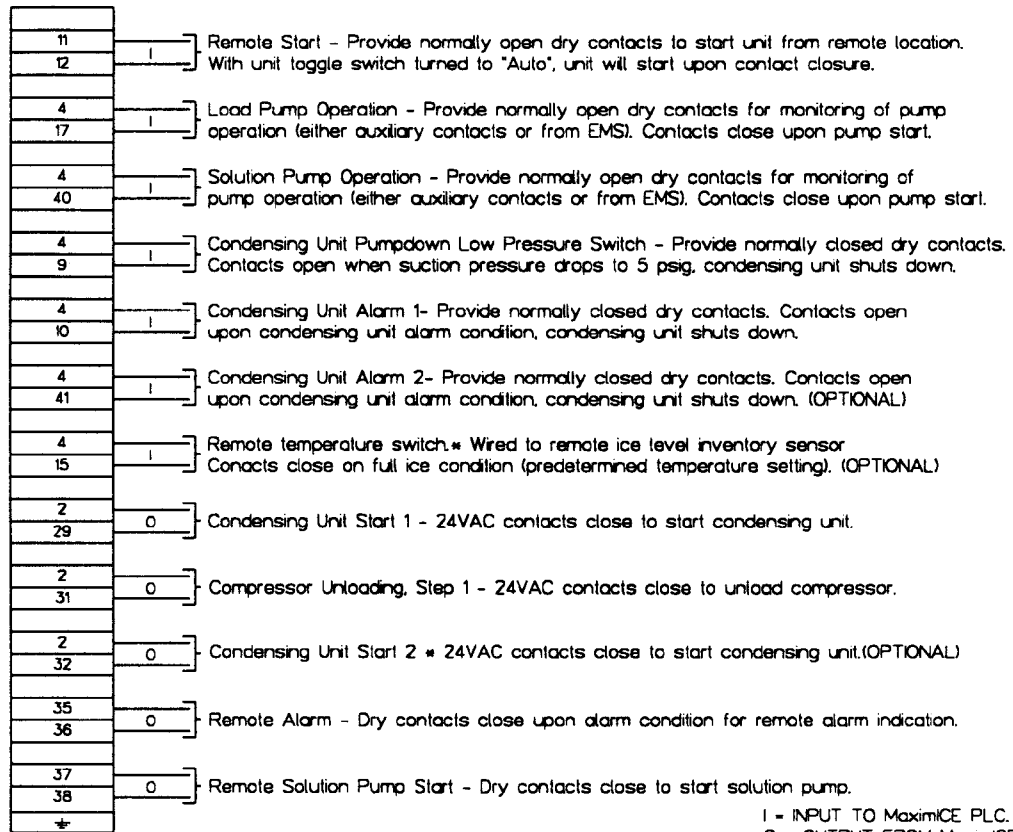

I = INPUT TO MaximICE PLC.  
O = OUTPUT FROM MaximICE PLC.

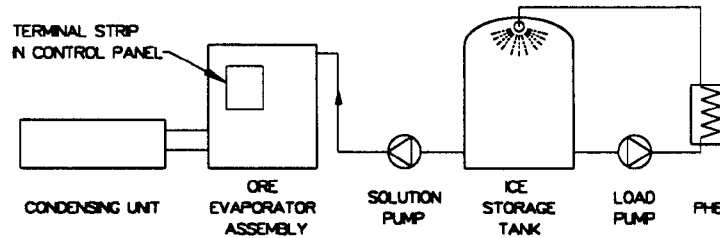

## THREE PHASE POWER

CUSTOMER SUPPLIED  
3 PHASE WITH GROUND

VOLTAGE	DRIVE MOTOR HP	MOTOR FLA (E.A.)	SLUSH PUMP HP / FLA	MIN. CIRCUIT AMPACITY	MAXIMUM OVERCURRENT PROTECTION
200/3/50	15	6	2 / 4.6	12.9	18.9
			3 / 5.6	13.9	19.9
208/3/60		5	2 / 5.9	13.1	19
			3 / 8.4	16.2	24.6
230/3/60		5.6	2 / 5.6	13.3	19.9
			3 / 8	16.3	24.3
380/3/50		3.2	2 / 2.2	7.5	10.7
			3 / 2.6	7.9	11.1
380/3/60		3.2	2 / 3	8.3	11.5
			3 / 4.4	10	14.4
460/3/60	2.8	2 / 2.8	7.4	10.2	
		3 / 4.0	8.9	12.9	

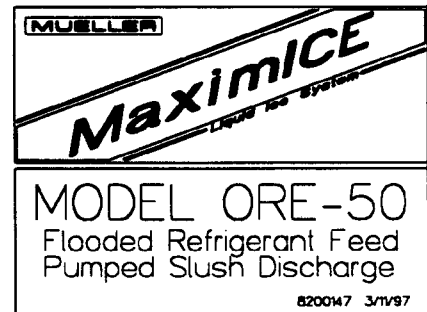

### 13.7 Model ORE-50 Flooded Refrigerant Feed, Gravity Slush Discharge, Drawing No. 8200154

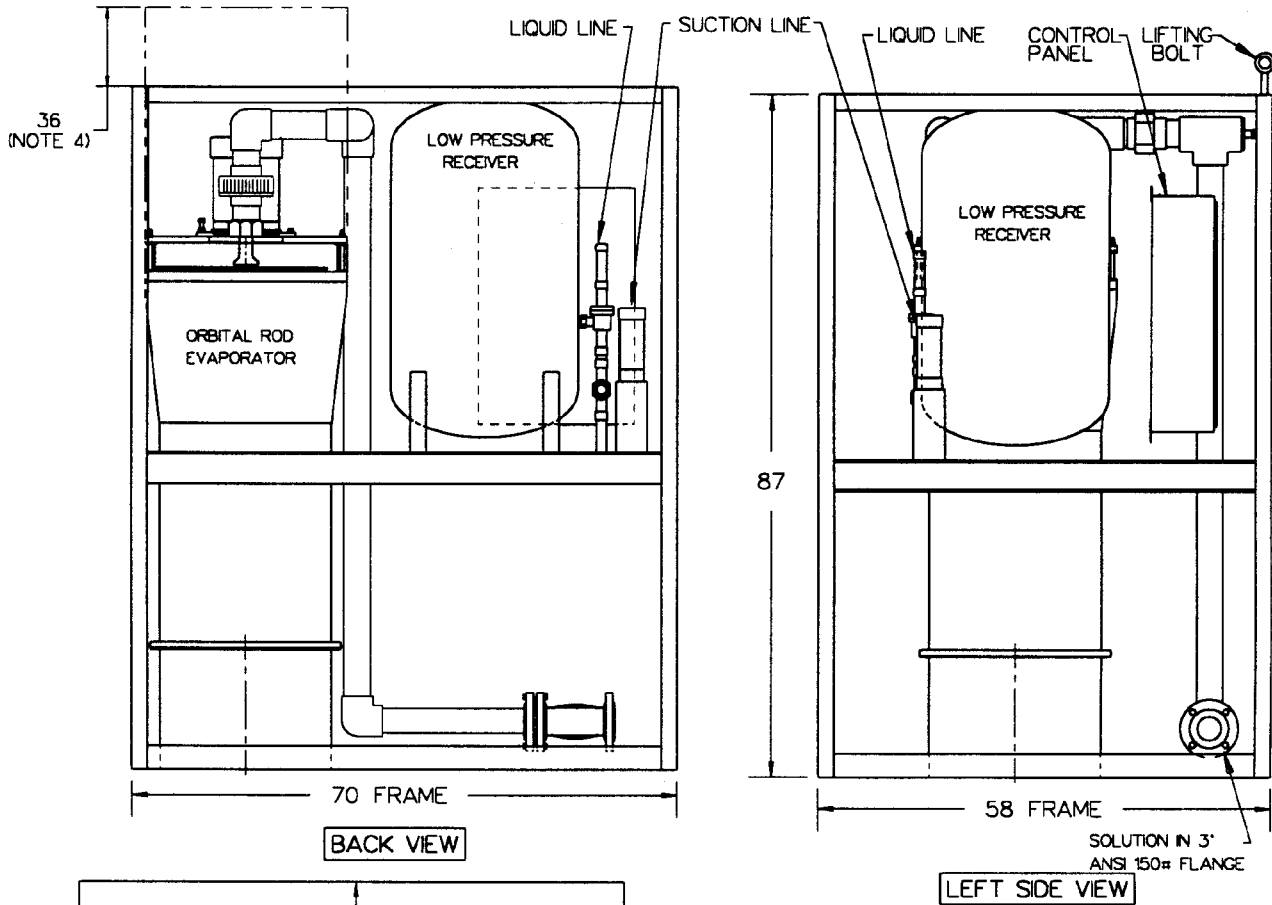

**NOTES:**

1. All dimensions are in inches unless specified otherwise.
2. PMC reserves the right to make product design changes which may alter the weights and or dimensions.
3. Three foot (3') minimum service clearance is required on all sides of assembly.
4. Three foot (3') minimum clearance above ORE is required for removal of whip rods.
5. Single point electrical connection through side of control panel.
6. Insulated paneling adds 5" to length, 5" to width, 2 1/2" to height.



SHIP WEIGHT (lbs)	DESIGN WEIGHT (lbs)	REFRIGERANT	REFRIGERANT CHARGE (lbs)	CONNECTIONS		SOLUTION FEED (IN)	
				SUCTION	LIQUID	FLOW RATE	NET PRESS. FEED
3.700	4.200	R-22	600	3 1/8" ODS	1 3/8" ODS	135 (gpm)	5-30 (psig)
		R-717	300	2 1/2" SCH 40	1" SCH 80		

**MODEL ORE-50**  
Flooded Refrigerant Feed  
Gravity Slush Discharge

8200154 3/11/97

# 13.8 Model ORE-50 Flooded Refrigerant Feed, Gravity Slush Discharge Schematic, Drawing No. 8200161

## SINGLE PHASE ORE-50 TYPICAL WIRING SCHEMATIC

\*Dual compressor condensing unit wiring shown. See unit wiring diagram for single condensing unit and optional items.

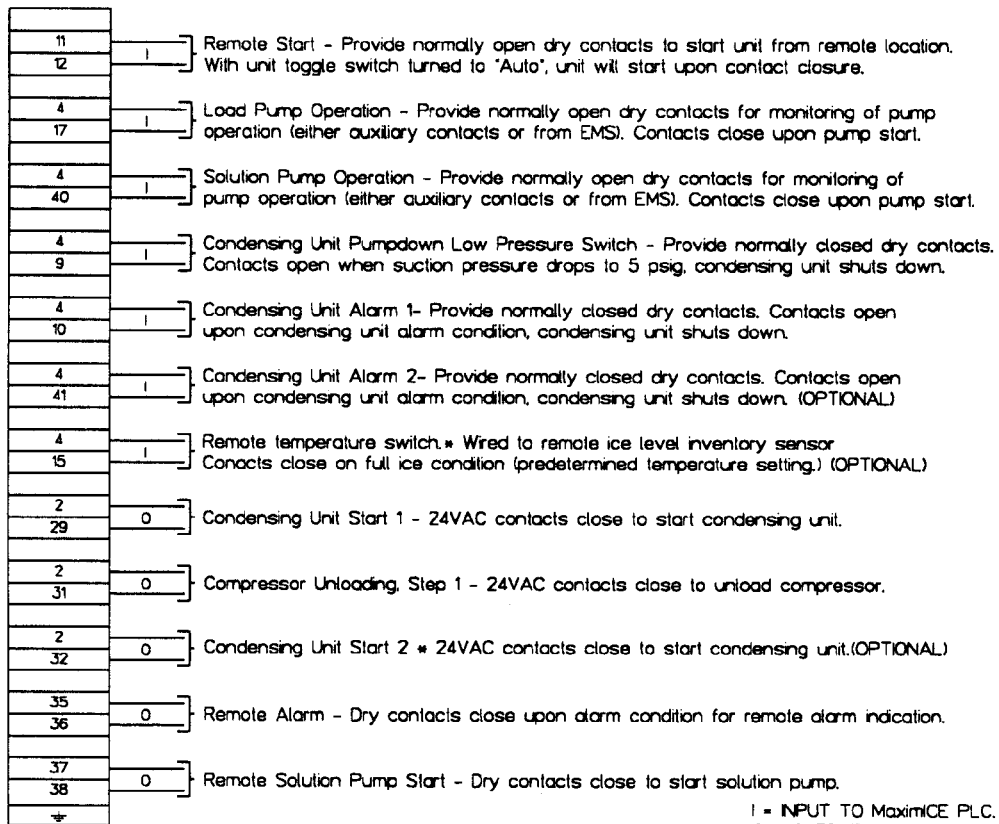

I = INPUT TO MaximICE PLC.  
O = OUTPUT FROM MaximICE PLC.

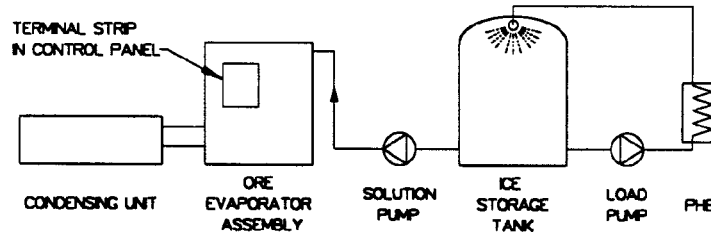

## THREE PHASE POWER

CUSTOMER SUPPLIED  
3 PHASE WITH GROUND

VOLTAGE	DRIVE MOTOR HP	MOTOR FLA (EAL)	MIN. CIRCUIT AMPACITY	MAXIMUM OVERCURRENT PROTECTION
200/3/50	15	6	8.3	14.3
208/3/60		5	7.0	12.0
230/3/60		5.6	7.7	13.3
380/3/50		3.2	5.3	8.5
380/3/60		3.2	5.3	8.5
460/3/60		2.8	4.6	7.4

**MUELLER**  
**MaximICE**  
LEAD THE SYSTEM

**MODEL ORE-50**  
Flooded Refrigerant Feed  
Gravity Slush Discharge

8200161 3/1/97

### 13.9 Model ORE-100 Flooded Refrigerant Feed, Pumped Slush Discharge, Drawing No. 8200141

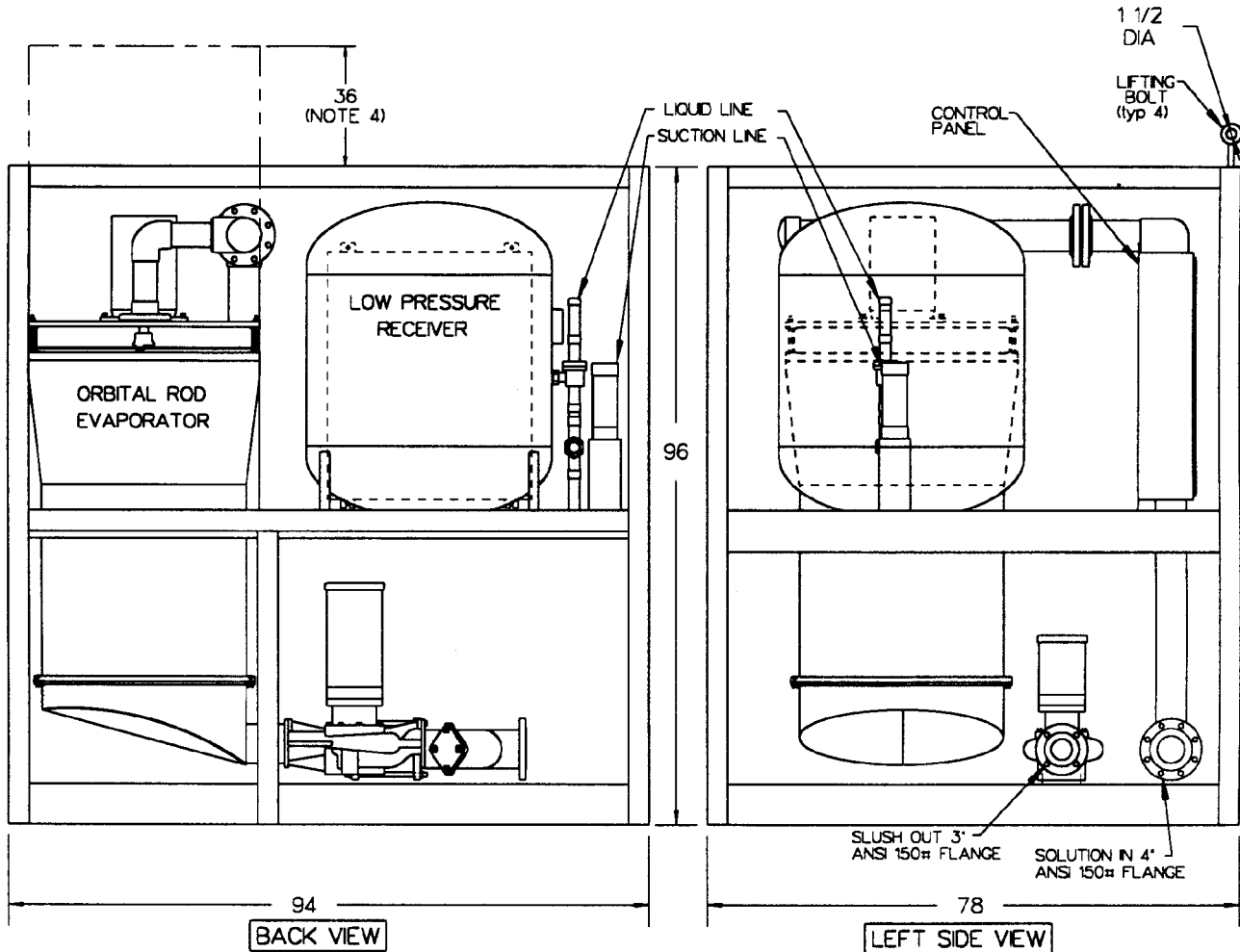

SHIP WEIGHT (lbs)	DESIGN WEIGHT (lbs)	REFRIGERANT	REFRIGERANT CHARGE (lbs)	CONNECTIONS		SOLUTION FEED (IN)		SLUSH PUMP (OUT)		
				SUCTION	LIQUID	FLOW RATE	NET PRESS REQD	HP	DISCHARGE HEAD	50 HZ
6,015	7,015	R-22	1,250	4 1/8" ODS	1 5/8" ODS	245 (gpm)	5-30 (psig)	3	21 FT	30 FT
		R-717	625	3 1/2" SCH 40	1 1/4" SCH 80			5	24 FT	38 FT
								7.5	44 FT	79 FT
								10	59 FT	97 FT

**NOTES:**

1. All dimensions are in inches unless specified otherwise.
2. PMC reserves the right to make product design changes which may alter the weights and or dimensions without prior notification.
3. Three foot (3') minimum service clearance is required on all sides of assembly.
4. Three feet (3') minimum clearance above ORE is required for removal of whip rods.
5. Single point electrical connection through side of control panel.
6. Insulated paneling adds 5" to length, 5" to width, 2 1/2" to height.

**MUELLER**

*MaximICE*

LIQUID ICE SYSTEM

---

MODEL ORE-100

Flooded Refrigerant Feed  
Pumped Slush Discharge

8200141 3/7/97

# 13.10 Model ORE-100 Flooded Refrigerant Feed, Pumped Slush Discharge Schematic, Drawing No. 8200148

## SINGLE PHASE ORE-100 TYPICAL WIRING SCHEMATIC

\*Dual compressor condensing unit wiring shown. See unit wiring diagram for single condensing unit and optional items.

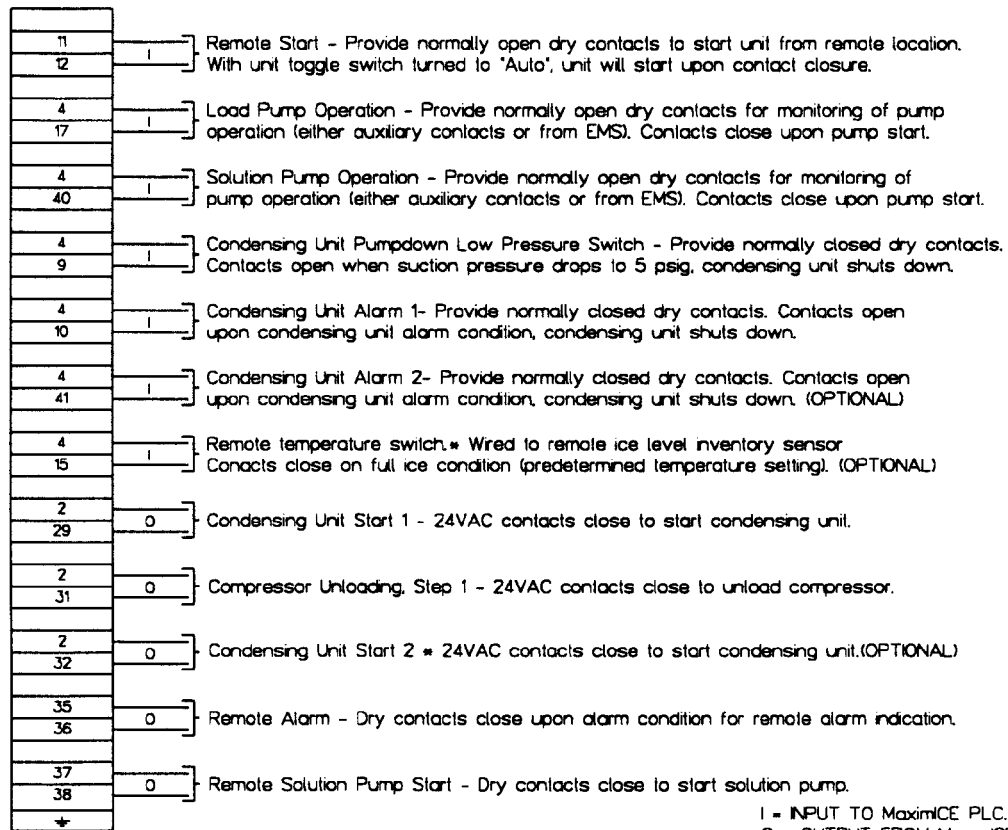

I = INPUT TO MaximICE PLC.  
O = OUTPUT FROM MaximICE PLC.

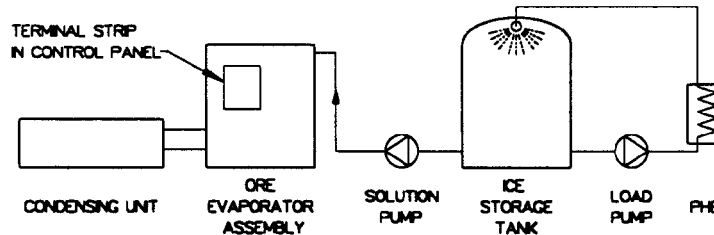

## THREE PHASE POWER

CUSTOMER SUPPLIED  
3 PHASE WITH GROUND

VOLTAGE	DRIVE MOTOR HP	MOTOR FLA (EA)	SLUSH PUMP HP / FLA	MIN. CIRCUIT AMPACITY	MAXIMUM OVERCURRENT PROTECTION
200/3/50	13.2	13.2	3 / 7.6	24.9	38.1
			5 / 7.6	24.9	38.1
			7.5 / 12	28.3	22.5
208/3/60	13.2	13.2	3 / 8.4	36.7	54.9
			5 / 8.4	36.6	38.8
			7.5 / 13	37.7	25.7
230/3/60	13.5	13.5	3 / 8	47.7	74.7
			5 / 11.5	25.5	39
			7.5 / 18	28.0	42.5
380/3/50	7.8	7.8	3 / 7.4	45.4	70.4
			5 / 7.4	45.1	22.9
			7.5 / 8.1	17.4	25
380/3/60	7.8	7.8	3 / 8.4	23.5	28.5
			5 / 7.3	18.4	28.2
			7.5 / 10.9	22.7	33.6
460/3/60	6.3	6.3	3 / 5.5	28.5	44
			5 / 4	13	18.3
			5 / 5.7	14.7	21
			7.5 / 9	18.6	27.5
			10 / 13	23.6	36.6

**MUELLER**  
**MaximICE**  
LIQUID ICE SYSTEM

**MODEL ORE-100**  
Flooded Refrigerant Feed  
Pumped Slush Discharge

8200148 3/11/97

### 13.11 Model ORE-100 Flooded Refrigerant Feed, Gravity Slush Discharge, Drawing No. 8200155

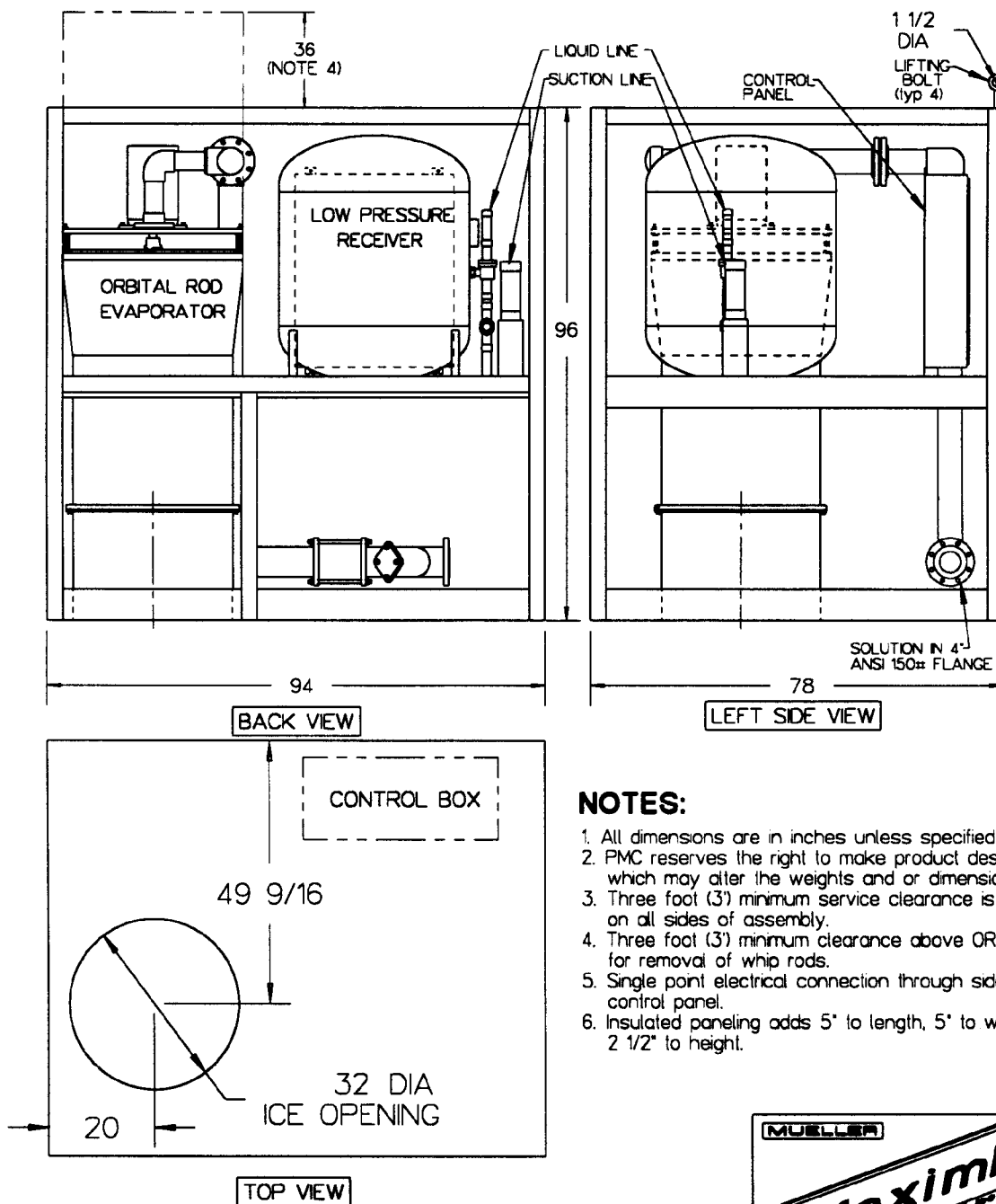

#### NOTES:

1. All dimensions are in inches unless specified otherwise.
2. PMC reserves the right to make product design changes which may alter the weights and or dimensions.
3. Three foot (3') minimum service clearance is required on all sides of assembly.
4. Three foot (3') minimum clearance above ORE is required for removal of whip rods.
5. Single point electrical connection through side of control panel.
6. Insulated paneling adds 5" to length, 5" to width, 2 1/2" to height.



SHIP WEIGHT (lbs)	DESIGN WEIGHT (lbs)	REFRIGERANT	REFRIGERANT CHARGE (lbs)	CONNECTIONS		SOLUTION FEED (IN)	
				SUCTION	LIQUID	FLOW RATE	NET PRESS. RECD
5.915	6.915	R-22	1250	4 1/8" ODS	1 5/8" ODS	245 (gpm)	5-30 (psig)
		R-717	625	3 1/2" SCH 40	1 1/4" SCH 80		

**MODEL ORE-100**  
Flooded Refrigerant Feed  
Gravity Slush Discharge

8200155 3/1/97

# 13.12 Model ORE-100 Flooded Refrigerant Feed, Pumped Slush Discharge Schematic, Drawing No. 8200162

## SINGLE PHASE ORE-100 TYPICAL WIRING SCHEMATIC

\*Dual compressor condensing unit wiring shown. See unit wiring diagram for single condensing unit and optional items.

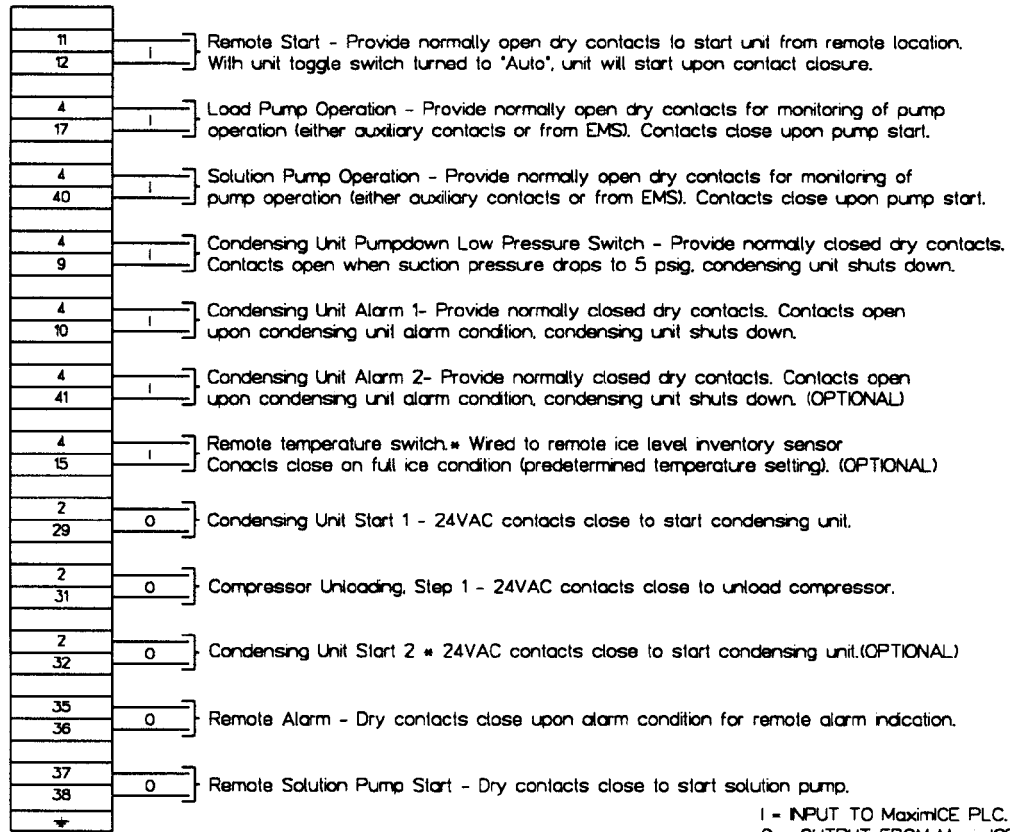

I = INPUT TO MaximICE PLC.  
O = OUTPUT FROM MaximICE PLC.

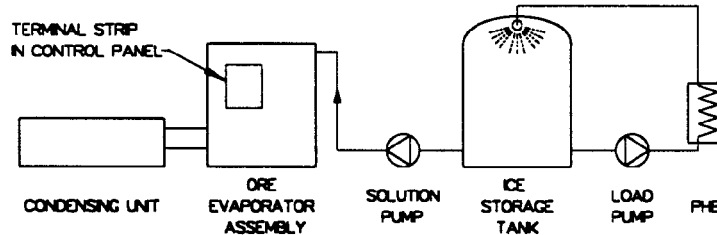

## THREE PHASE POWER

CUSTOMER SUPPLIED  
3 PHASE WITH GROUND

VOLTAGE	DRIVE MOTOR HP	MOTOR FLA (E.A.)	MIN. CIRCUIT AMPACITY	MAXIMUM OVERCURRENT PROTECTION
200/3/50	3	13.2	17.3	30.5
208/3/60		13.2	17.2	30.4
230/3/60		13.5	17.5	31
380/3/50		7.8	11.1	18.9
380/3/60		7.8	11.1	18.9
480/3/60		6.3	9	15.3

**MUELLER**

MaximICE

Liquid for System

---

MODEL ORE-100

Flooded Refrigerant Feed  
Gravity Slush Discharge

8200162 3/1/97

## **SECTION 14.0 - START-UP REQUEST FORM**

### **14.0 Start-Up Request Form**

I request that a factory-authorized service representative be scheduled to perform start-up on or about the week of \_\_\_\_\_. Please note that this is a requested date and must be confirmed by the service department. Start-up is usually performed within five days (travel included). Upon arrival on site, the start-up technician will verify that the system is capable of being started and that the items identified in the prestart-up check list have been satisfied.

If site construction/installation cannot be completed within 24 hours, the service technician will depart from the job site. In this situation, all costs associated with this trip will be charged to the purchaser on a time-and-material basis. The technician will return to the installation site to perform start-up upon the following conditions:

- ▲ Verification of the purchaser that all construction items/issues are in compliance with and satisfy the concerns of the start-up technician.
- ▲ Full payment has been received for the initial start-up trip.

Please fax to (417) 862-9008, attention Thermal Energy Storage Department. You will be contacted within two weeks to confirm the start-up of your unit(s). Contact our service department if you have any questions regarding this form or the installation of your equipment. We will be happy to assist you.

## SECTION 15.0 - WARRANTY

# WARRANTY

---

## Mueller® MaximICE® for Thermal Storage

### One-Year Parts Warranty

Paul Mueller Company (*hereinafter referred to as Company*) will repair or (or at the *Company's* option) replace any part or portion of a Mueller MaximICE Evaporator Assembly found to be defective in workmanship or material under normal use, service, and installation procedures, for a period of one (1) year from date of installation by the original purchaser/user or eighteen (18) months from the date of shipment from the *Company* factory, whichever occurs first. This Warranty covers replacement of parts or repair of the equipment only. This warranty does not cover consumable products or parts such as refrigerant, driers, glass, or rubber components (See General Provisions.)

### Claim Procedure for One-Year Parts Warranty

All defective parts covered by the one-year parts warranty must be returned to Paul Mueller Company with an attached Returned Goods Tag (O-209) and with transportation cost prepaid. Current instructions for return procedures, provided by the Thermal Storage Products Service Department, must be followed to receive warranty.

### General Provisions

This warranty does not cover items such as: refrigerant, transportation, mileage, freight, product loss, cost of substitutions, or labor and parts charged by others. Replacement and/or repair of certain components not manufactured by the *Company* will be handled by authorized service stations designated by the manufacturer of the component. Transportation and inspection cost incurred by the *Company* will be charged to the purchaser/user if returned material is not found to be defective. The above will constitute the *Company's* total responsibility. The above warranties will not apply in the event of abuse; negligence; improper installation procedures; alterations by unauthorized service; damage by flood, fire, windstorm, lightning; or acts of God. Oral statements made by employees or representatives of the *Company*, will not constitute warranties. The above warranties apply only to the original purchaser/user and original installation location and are not transferable.

**MUELLER**®

THERMAL STORAGE PRODUCTS

#### Paul Mueller Company

P.O. Box 828 • Springfield, Missouri 65801-0828, U.S.A.  
Telephone: (417) 831-3000 • Facsimile: (417) 862-9008



**MUELLER**®

P.O. Box 828 • Springfield, Missouri 65801-0828, U.S.A.  
Phone: (417) 831-3000 • 1-800-MUELLER • Fax: (417) 862-9008  
www.muel.com • E-mail: thermal@muel.com

International Inquiries: Fax: (417) 831-6906 • E-mail: international@muel.com

(12/00) Part No. 9840502