



Construction Details

Series V

Model VC2 Evaporative Condensers

Spray Branches

Heat Transfer Coil Section

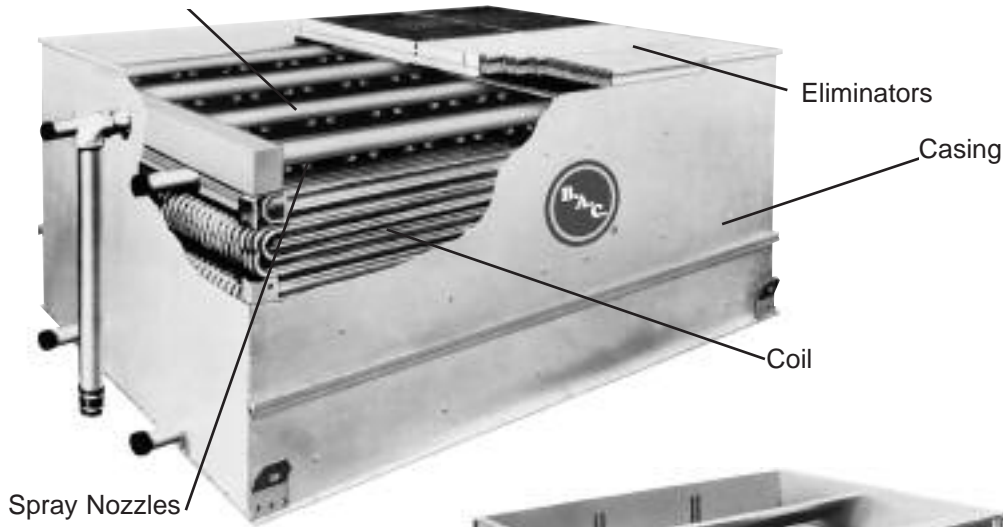

Water Make-up Valve Assembly

Basin Section

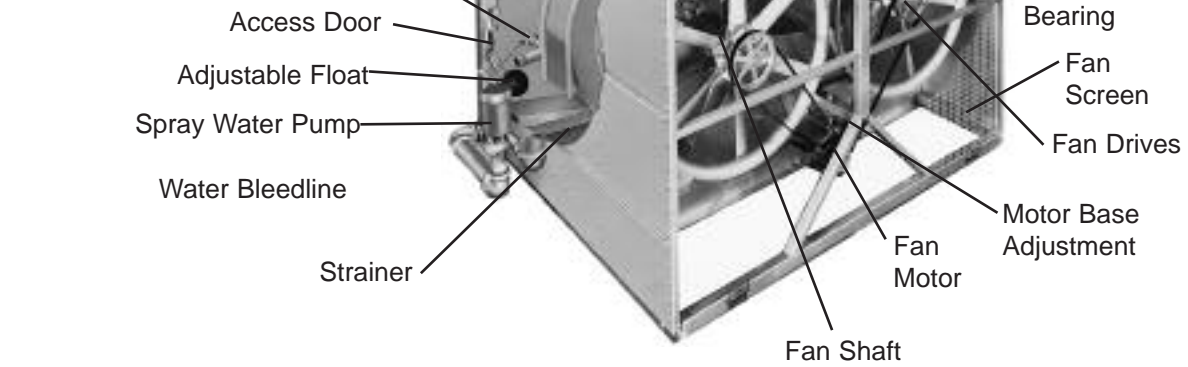

Pump End

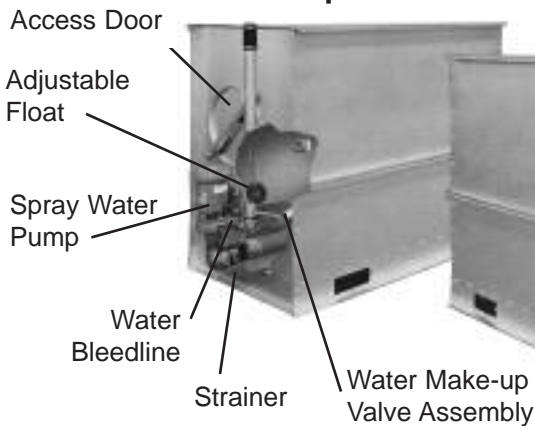

Fan End

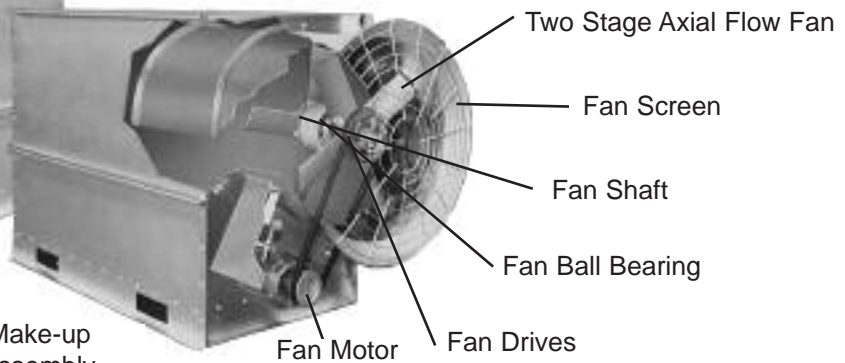

Operating and Maintenance Manuals

...because temperature matters™





Baltimore Aircoil Company

Series V

RIGGING AND INSTALLATION INSTRUCTIONS

Introduction

Series V and Low Profile Series V Products should be rigged and assembled as outlined in this bulletin. These procedures should be thoroughly reviewed prior to the actual rigging operation to acquaint all personnel with procedures to be followed and to assure that all necessary equipment will be available beforehand.

Locate the unit nameplate on the connection end of the unit and record the unit serial number and model number for reference.

Open Cooling Towers are identified as VT0, VT1 or VTL; Evaporative Condensers as VC1, VC2, or VCL; and Closed Circuit Cooling Towers as VF1 and VFL.

Be sure to have a copy of the certified drawing available for reference. If you do not have a copy of this drawing, or if you need additional information about this unit, contact the local BAC Representative whose name and telephone number are on a label at the connection end of your unit.

CHECK UNIT BEFORE RIGGING

When the unit is delivered to the jobsite, it should be checked thoroughly to ensure all required items have been received and are free of any shipping damage prior to signing the bill of lading. The following parts should be inspected:

- Sheaves and Belts
- Bearings
- Bearing Supports
- Fan Motor(s)
- Fan Wheel(s) & Shaft(s)
- Fill (VT0, VT1 & VTL)
- Miscellaneous Items:
- Coils (VC1, VC2, VCL, VF1, VFL)
- Water Distribution System
- Strainers
- Float Valve Assembly
- Eliminators
- Interior & Exterior Surfaces

If required for field assembly, the following parts will be packaged and usually placed inside the basin-fan section: Sealer, Self-Tapping Screws, and Accessory Items. A checklist inside the envelope attached to the side of the unit marked "Contractor's Installation Instructions" indicates what miscellaneous parts were included with the shipment and where they were packed. Be sure to remove all accessory items from the basin before the unit is assembled.

UNIT WEIGHTS

Before rigging any Series V Product, the weight of each section should be verified from the unit certified drawing. Some accessories add additional weight as shown on the respective accessory drawings.

WARNING: These weights are approximate only and should be confirmed by weighing before lifting when available hoisting capacity provides little margin for safety. In preparing for a lift, individuals responsible for rigging BAC units must inspect the equipment before the lift to make certain that all water or other liquids have been drained from the unit and any debris removed.

During cold weather, the pre-lift procedure must include a check for and removal of accumulations of ice and snow, which will not naturally drain from the equipment and would add substantially to the equipment's lifting weight.

ANCHORING

CAUTION: Unit must be properly anchored in place before operation begins.

Seven-eighths inch (7/8") diameter bolt holes are provided in the bottom flange of the basin section for bolting the unit to the support beams. Refer to the suggested support details on the certified drawing for locations of the mounting holes. Anchor bolts are supplied by others.

LEVELING

The unit must be level for proper operation. This is especially true for Closed Circuit Cooling Towers (VF1 and VFL units), which should be leveled to 1/8" in 18' over the unit length and to 1/8" over the unit width. This will help ensure proper coil draining in an emergency freeze situation. [See Freeze Protection Note below]. Support beams must also be level. Shims should not be used between the basin and support beams to level the unit.

NOTICE—Operation, maintenance and repair of this equipment should be undertaken only by personnel qualified to do so. Proper care, procedures and tools must be used in handling, lifting, installing, operating, maintaining and repairing this equipment to prevent personal injury and/or property damage.

SAFETY—Adequate precautions, appropriate for the installation and location of these products should be taken to safeguard the public from possible injury and the equipment and the premises from damage.

Air inlet bottom screens or solid bottom panels may be desirable or necessary for safety and other reasons depending on the location and conditions at the installation site.

WARNING—PVC eliminators on this product are not designed to support the weight of a person or to be used as a storage or work surface for any equipment or tools. Use of these plastic eliminators as walking, working or storage surface may result in injury to personnel or damage to equipment.

If covering a unit which has PVC eliminators, do not use a clear plastic tarpaulin.

For a discussion of Safety Precautions to be followed when operating or maintaining this equipment, please refer to the equipment's Operating and Maintenance Instructions.

WARRANTIES—Please refer to the Limitation of Warranties applicable to and in effect at the time of the sale/purchase of these products.

FREEZE PROTECTION—These products must be protected by mechanical and operational methods against damage and/or reduced effectiveness due to possible freeze-up. Please refer to the product catalog, Operation and Maintenance Manual or contact the local BAC Representative for recommended protection alternatives.

RIGGING

To simplify rigging and installation, most Series V Units are shipped in sections consisting of the basin-fan assembly and one or more casing sections. Some smaller Series V and all Low Profile Units ship fully assembled. See Figure 1 for further identification of these units.

WARNING: Unless the unit ships fully assembled, basin-fan and casing components must be rigged separately. Never assemble the unit before lifting as the lifting devices provided are not designed to support the weight of the entire assembled unit.

The proper rigging sequence for Series V Units is to lift the basin-fan section into place, apply sealer to the basin where the casing(s) will be located, and then lift the casing(s) into place. For a fully factory pre-assembled unit, only one lift is required. Lifting devices have been provided on all sections. Spreader bars, the full width of the section, must be used between the lifting cables to prevent damage to the section. The use of safety slings is recommended whenever hazards exist.

The tables on pages 2 and 3 give the preferred method for rigging each section of any Series V Unit. With the information from the tables and the additional instructions on pages 4 through 8, rigging a Series V Unit can be quickly accomplished as follows:

- Using the appropriate table, locate the model number of the unit to be rigged. Following the model number are: the type and number of sections to be rigged; basin-fan rigging method with the required spreader bar length and minimum allowable vertical distance "H" from the lifting devices to the rigging hook; sealing method; casing rigging method with spreader bar length and minimum "H"; and the correct eliminator placement. The methods are defined in the following pages.
- Rig the basin-fan section by the method listed in the unit tables. Caution: Before proceeding to the next operation, bolt the basin-fan section securely to the supporting steel. For VC2 units the rigging hook must be placed above the section's center of gravity as detailed in Rigging Method "F", on page 4.
- Apply sealer to the flanges where the casings are to be located. Again, refer to the unit tables for the proper method.
- Rig the casing section(s) by the method listed in the unit tables, ensuring correct mounting hole alignment with the basin-fan section.
- Complete the final assembly details outlined on pages 6 through 8. For correct placement of the eliminators, refer to the unit tables.

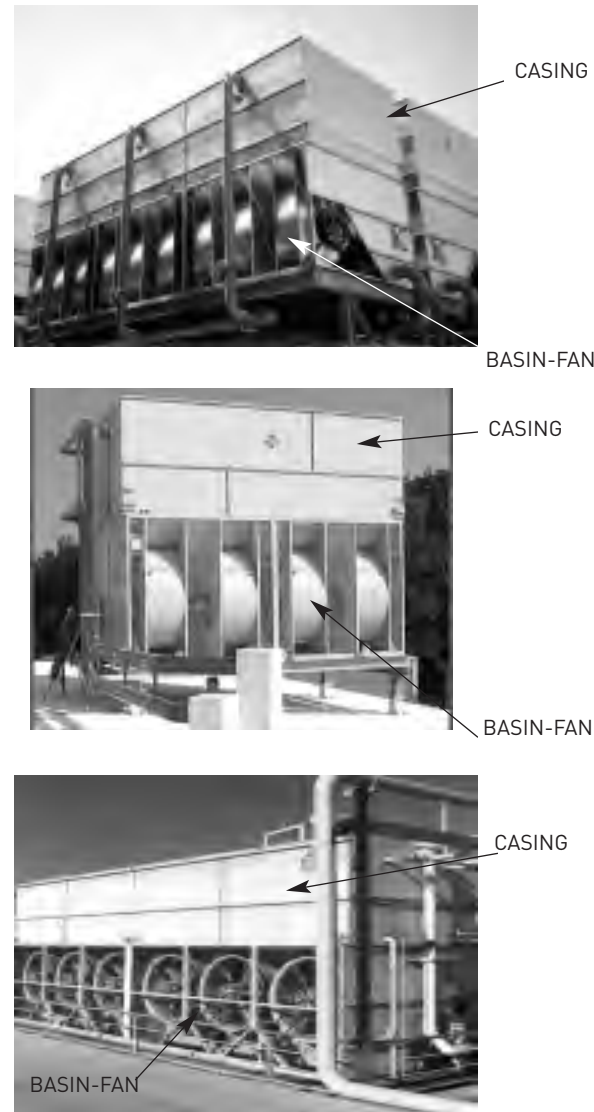

Figure 1

COOLING TOWERS

MODEL NO.	NO. OF PANS	NO. OF CASINGS	BASIN-FAN SECTION			SEALING METHOD	CASING SECTION			ELIMINATOR PLACEMENT	
			Rigging Method	Spreader Bar Length	Minimum "H"		Rigging Method	Spreader Bar Length	Minimum "H"	Std. PVC	Opt. Steel
VT0-12-E thru 19-G	FULLY ASSEMBLED		A	3'	8'	-	-	-	-	S	S
VT0-24-G thru 28-H	1	1	C	4'	8'	I	L	3'	8'	S	S
VT0-32-H thru 41-J	FULLY ASSEMBLED		A	6'	8'	-	-	-	-	S	S
VT0-52-J thru 57-K	1	1	C	6'	8'	I	L	6'	8'	S	S
VT0-65-J thru 88-L	1	1	C	4'	10'	I	L	9'	9'	S	S
VT0-102-L thru 116-M	1	1	C	4'	12'	I	L	12'	12'	S	S
VT0-132-L thru 176-O	1	1	C	4'10"	12'	I	M	4'10"	8'	S	S
VT1-N209-P thru N255-P	1	1	C	8'	12'	I	N	8'	14'	S	U
VT1-N301-Q thru N395-R	1	1	C	8'	16'	I	N	8'	18'	S	U
VT1-N418-P thru N510-P	1	2	C	8'	20'	J	N	8'	14'	S	U
VT1-275-P thru 415-R	1	1	C	12'	14'	I	N	12'	16'	S	U
VT1-416-O thru 600-P	1	1	C	12'	18'	I	N	12'	20'	S	U
VT1-416-O thru 600-P*	1	2	C	12'	18'	J	M	12'	16'	S	U
VT1-550-P thru 830-R	1	2	C	12'	22'	J	N	12'	16'	S	U
VT1-825-P thru 1335-S	1	3	D	12'	22'	K	N	12'	16'	S	U
VTL-016-E thru 039-H	FULLY ASSEMBLED		E	4'	9'	-	-	-	-	W	W
VTL-045-H thru 079-K	FULLY ASSEMBLED		E	4'	10'	-	-	-	-	W	W
VTL-082-K thru 095-K	FULLY ASSEMBLED		E	4'	14'	-	-	-	-	W	W
VTL-103-K thru 137-M	FULLY ASSEMBLED		E	4'	16'	-	-	-	-	W	W
VTL-152-M thru 227-O	FULLY ASSEMBLED		E	8'	14'	-	-	-	-	W	W
VTL-245-P thru 272-P	FULLY ASSEMBLED		E	8'	16'	-	-	-	-	W	W

* Use this alternative rigging sequence for all VT1-416-0 through VT1-600-P units with 2 casing sections.

EVAPORATIVE CONDENSERS

MODEL NO.	NO. OF PANS	NO. OF CASINGS	PAN-FAN SECTION			SEALING METHOD	CASING SECTION			ELIMINATOR PLACEMENT	
			Rigging Method	Spreader Bar Length	Minimum "H"		Rigging Method	Spreader Bar Length	Minimum "H"	Std. PVC	Opt. Steel
VC1-10 thru 15	FULLY ASSEMBLED		B	3'7"	8'	—	—	—	—	S	S
VC1-20 thru 25	1	1	C	4'	12'	I	N	3'7"	12'	S	S
VC1-30 thru 38	FULLY ASSEMBLED		B	3'7"	8'	—	—	—	—	S	S
VC1-46 thru 65	1	1	C	4'	12'	I	N	3'7"	12'	S	S
VC1-72 thru 80	FULLY ASSEMBLED		B	3'7"	8'	—	—	—	—	S	S
VC1-90	1	1	C	4'	12'	I	N	3'7"	12'	S	S
VC1-100 thru 110	FULLY ASSEMBLED		B	3'7"	8'	—	—	—	—	S	S
VC1-125 thru 135	1	1	C	4'	12'	I	M	3'7"	12'	S	S
VC1-150 thru 205	1	1	C	4'10"	12'	I	N	4'10"	12'	S	S
VC1-N243 thru N315	1	1	C	8'	12'	I	N	8'	14'	S	U
VC1-C216 thru C321	1	1	C	7'5"	12'	I	N	7'5"	14'	S	U
VC1-N338 thru N470	1	1	C	8'	16'	I	N	8'	18'	S	U
VC1-C339 thru C469	1	1	C	7'5"	16'	I	N	7'5"	18'	S	U
VC1-386 thru 516	1	1	C	12'	14'	I	N	12'	14'	S	U
VC1-540 thru 804	1	1	C	12'	18'	J	N	12'	18'	S	U
VC1-772 thru 1032	1	2	C	12'	22'	J	N	12'	14'	S	U
VC1-1158 thru 1608	1	2	D	12'	22'	I	N	12'	18'	S	U
VC2-N138 thru N191	1	1	F	5'	16'	I	N	5'	12'	V	R
VC2-N206 thru N235	1	1	F	5'	18'	I	N	5'	12'	V	R
VC2-N261 thru N301	1	1	F	8'	18'	I	N	8'	14'	V	R
VC2-N356 thru N446	1	1	F	8'	22'	I	N	8'	18'	V	R
VC2-319 thru 580	1	1	C	12'	14'	I	N	12'	14'	S	U
VC2-526 thru 887	1	1	C	12'	18'	I	N	12'	18'	S	U
VC2-684 thru 1160	1	2	C	12'	22'	J	N	12'	14'	S	U
VC2-1052 thru 1774	1	2	G	12'	22'	J	N	12'	18'	S	U
VCL-016 thru 035	FULLY ASSEMBLED		E	4'	9'	—	—	—	—	W	W
VCL-038 thru 079	FULLY ASSEMBLED		E	4'	10'	—	—	—	—	W	W
VCL-087 thru 120	FULLY ASSEMBLED		E	4'	10'	—	—	—	—	W	W
VCL-134 thru 155	FULLY ASSEMBLED		E	4'	12'	—	—	—	—	W	W
VCL-167 thru 234	FULLY ASSEMBLED		E	8'	10'	—	—	—	—	W	W
VCL-257 thru 299	FULLY ASSEMBLED		E	8'	12'	—	—	—	—	W	W

CLOSED CIRCUIT COOLING TOWERS

MODEL NO.	NO. OF PANS	NO. OF CASINGS	BASIN-FAN SECTION			SEALING METHOD	CASING SECTION			ELIMINATOR PLACEMENT	
			Rigging Method	Spreader Bar Length	Minimum "H"		Rigging Method	Spreader Bar Length	Minimum "H"	Std. PVC	Opt. Steel
VF1-009-1X or 2X	FULLY ASSEMBLED		B	3'7"	8'	—	—	—	—	S	S
VF1-009-3X or 4X	1	1	C	4'	12'	I	N	3'7"	12'	S	S
VF1-018-0X or 1X	FULLY ASSEMBLED		B	3'7"	8'	—	—	—	—	S	S
VF1-018-2X, 3X or 4X	1	1	C	4'	12'	I	N	3'7"	12'	S	S
VF1-027-2X, 3X or 4X	1	1	C	4'	12'	I	N	3'7"	12'	S	S
VF1-036-2X, 3X, 4X or 5X	1	1	C	4'	12'	I	N	3'7"	12'	S	S
VF1-048-X	1	1	C	4'10"	12'	I	N	4'10"	12'	S	S
VF1-072-X	1	1	C	8'	16'	I	N	6'7"	16'	S	U
VF1-096-X	1	1	C	8'	12'	I	N	8'	14'	S	U
VF1-144N-X	1	1	C	8'	16'	I	N	8'	18'	S	U
VF1-192-X	1	2	C	8'	20'	J	N	8'	14'	S	U
VF1-288N-X	1	2	D	8'	22'	J	N	8'	18'	S	U
VF1-144-X	1	1	C	12'	14'	I	N	12'	14'	S	U
VF1-216-X	1	1	C	12'	18'	I	N	12'	18'	S	U
VF1-288-X	1	2	C	12'	22'	J	N	12'	14'	S	U
VF1-432-X	1	2	D	12'	22'	J	N	12'	18'	S	U
VFL-012-XXX	FULLY ASSEMBLED		E	4'	9'	—	—	—	—	W	W
VFL-024-XXX	FULLY ASSEMBLED		E	4'	10'	—	—	—	—	W	W
VFL-036-XXX	FULLY ASSEMBLED		E	4'	14'	—	—	—	—	W	W
VFL-048-XXX	FULLY ASSEMBLED		E	4'	16'	—	—	—	—	W	W
VFL-072-XXX	FULLY ASSEMBLED		E	8'	10'	—	—	—	—	W	W
VFL-096-XXX	FULLY ASSEMBLED		E	8'	12'	—	—	—	—	W	W

BASIN-FAN RIGGING METHODS

1. Rig basin-fan section. Bolt section securely to the supporting steel before proceeding to the next step.

A

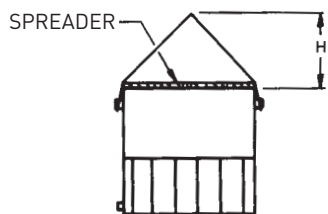

SAFETY SLINGS RECOMMENDED

B

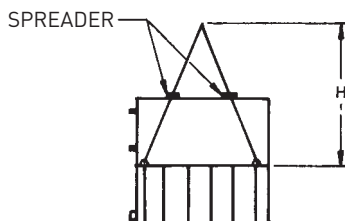

SAFETY SLINGS RECOMMENDED

C

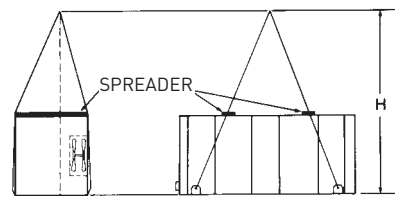

CG=62"
VC2-319 thru 1160

D

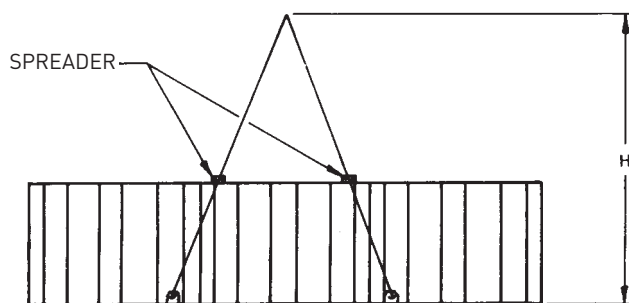

E

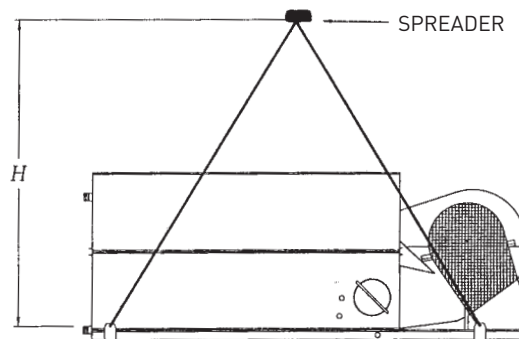

SAFETY SLINGS RECOMMENDED

F

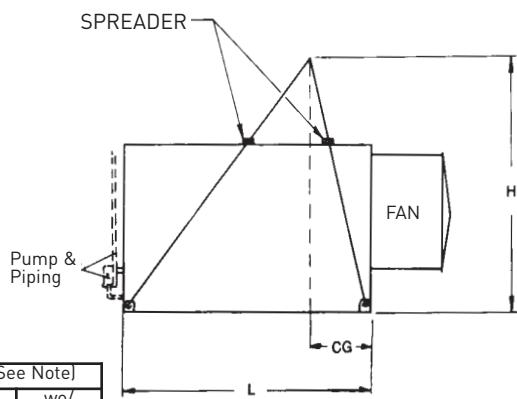

L	CG [See Note]	
	w/ Pump	wo/ Pump
3'	15"	9"
6'	27"	21"
9'	41"	34-1/2"
12' x 4 to 6-1/2' wide	59-1/2"	46-3/4"
12' x 8' wide	55"	38-1/2"
18'	89-1/2"	67"

NOTE: CG varies with pump arrangement.
Locate cable apex above appropriate CG
points shown in table.

G

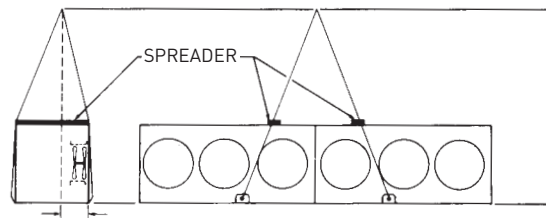

CG=62"
VC2-1052 thru 1774

SEALING METHODS

- Remove any protective wood from the top horizontal flanges of basin-fan section. Wipe down the flanges to remove dust, dirt or moisture that may have accumulated during shipment and storage.
- Apply the 1" flat butyl sealer tape around the periphery of the top flange of the basin-fan section as shown below in Diagrams I, J or K (See Figure 2). This butyl sealer tape must be centered directly over the centerline of the taper holes and on the centerline of the end flanges where there are no taper holes.

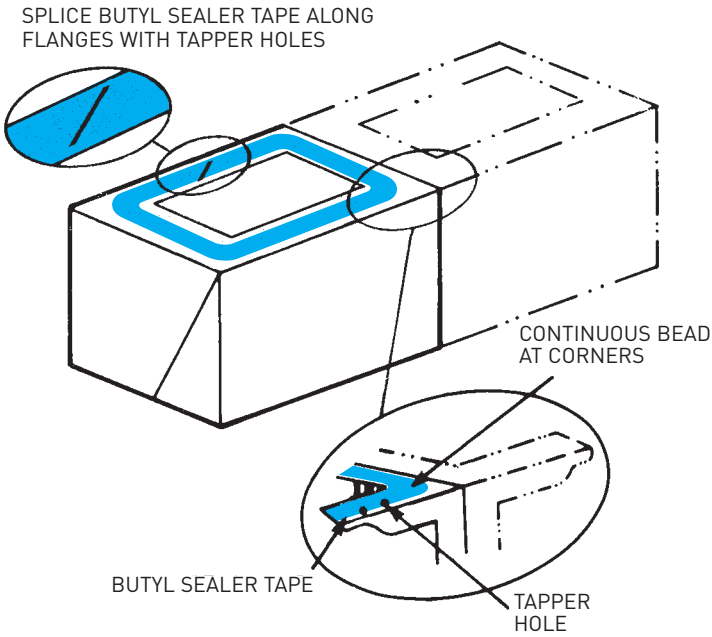

Figure 2

NOTE: Butyl Sealer Tape is trapezoidal in shape and must be installed wide side down (Figure 3).

- Sealer applied to the end flanges of a single cell section unit and to the end and center flanges of two cell units must be continuous. The sealer is to be spliced only along the flanges with taper holes. When it is necessary to splice sealer, miter and press the two ends together so as to form a smooth, continuous bead.
- On VC1, VC2, and VF1 Units, lower the flexible connection on the pump discharge piping below the elevation of the basin-fan section top flange before rigging casing section.

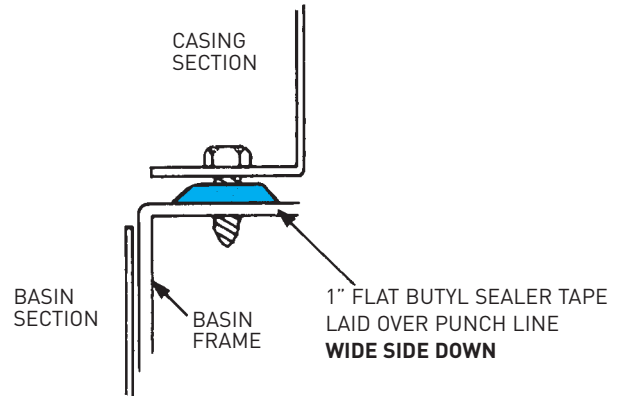
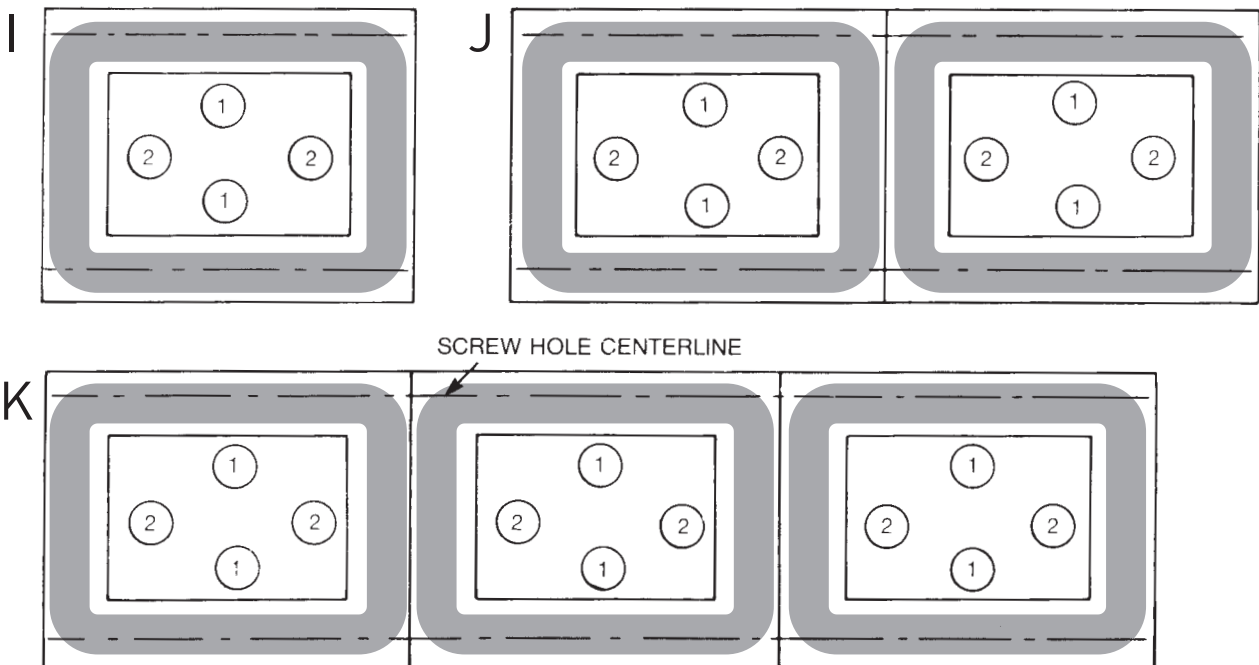

Figure 3

- On units with more than one casing section, install the remaining casing sections using the same procedure as with the first. However, when installing two or more casings on the basin-fan section, sealer must be applied to both cross flanges (See Diagrams I, J, and K.)

- Apply 1" flat butyl sealer tape centerline of screw hole.
- Apply 1" flat butyl sealer tape over centerline of cross flanges.



CASING RIGGING METHODS

7. After applying sealer to the basin-fan flanges, remove the casing skid. Lift the casing section and position it over the basin-fan section so that the casing flanges are about 2" above the basin-fan section. Do not permit the casing to swing and damage the sealer.



Figure 4

8. Insert drift pins downward through the four corner screw holes in the casing section (See Figure 4). Continue to lower the casing section slowly, maintaining alignment with the drift pins until it rests on the basin-fan section.

9. Using the 5/16" self-tapping screws, drive the corner screws down through the casing section and into the basin-fan section. Working from the corners toward the center, continue to install the self-tapping screws, using the drift pin, to align the screw holes.

10. On VC1, VC2, and VF1 units, secure the flexible hose that connects the upper and lower sections of the pump discharge pipe using the hose clamps provided.

11. Remove any wooden bracing from around the eliminators or casing.

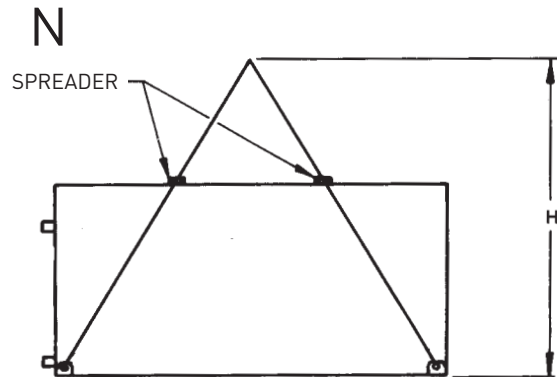
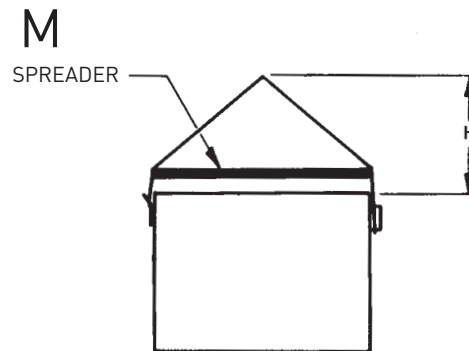
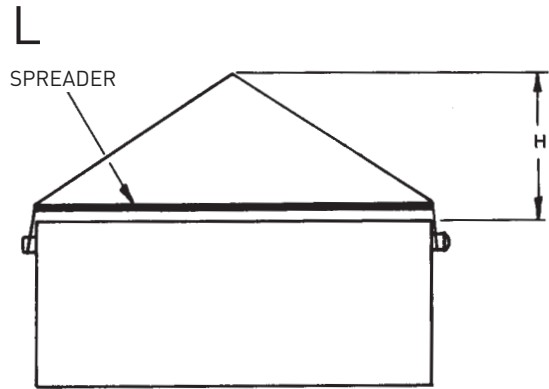

FINAL ASSEMBLY DETAILS

12. PLACEMENT OF ELIMINATORS

Check the placement of the eliminator sections on the top of the unit against the placement listed in the Unit Tables on pages 2 and 3.

Eliminator Placement -(continued)

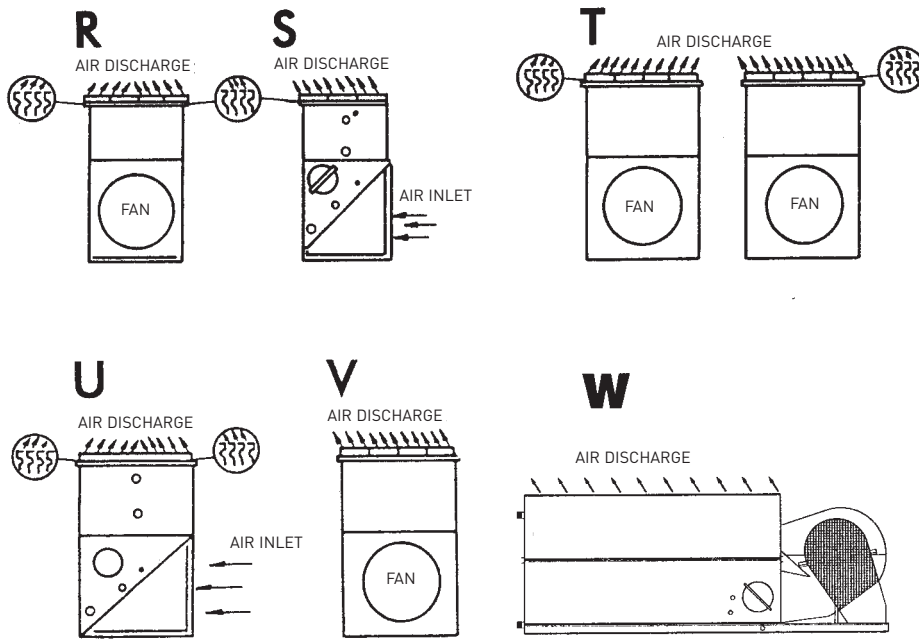

13. DISCHARGE HOODS

For most Series V Units, the sealing method for discharge hoods is the same as in the casing sealing instructions. An alternate sealing method is used on units VC1-10 thru VC1-205, and VF1-009 thru VF1-072.

ALTERNATE DISCHARGE HOOD SEALING METHOD

1. Apply a continuous strip of 1" butyl sealer tape around top horizontal flange of casing.
2. Eliminators are shipped inside hood. Be sure eliminators are resting on inside flanges of hood section.
3. Lower hood onto casing as shown.
4. Using clamps, wing nuts, or tappers provided, attach hood to casing. Refer to Section A-A.

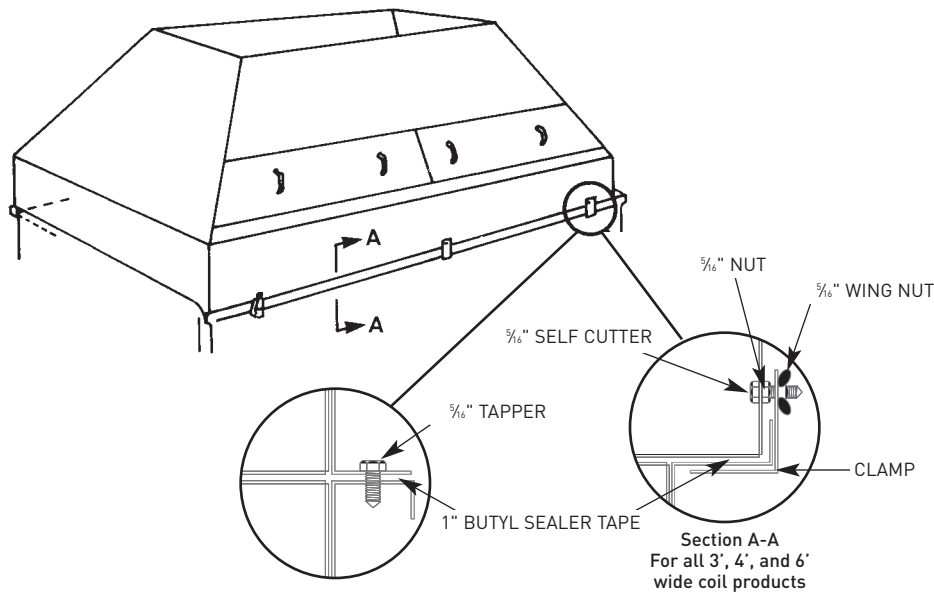

Section A-A
For all VT0 and VT1 Cooling Towers, all Low Profile Series V Units, and all 8' and 12' wide coil products

Section A-A
For all 3', 4', and 6' wide coil products

14. INSPECTION

Prior to start-up, the following services, which are described in detail in the Operating and Maintenance Manual, must be performed:

- Inspect the general condition of unit
- Inspect fans, motors, bearings, drives, locking collars, and belts for condition and alignment.
- Lubricate all bearings and purge them of old grease.
- Inspect spray nozzles and heat transfer section.
- Check make-up valve and basin water level.
- Check fans and air inlet screens for obstructions.
- Clean and flush basin and strainer.

Proper start-up procedures and scheduled periodic maintenance will prolong the life of the equipment and ensure trouble-free performance for which the unit is designed.

15. BLEED LINE INSTALLATION

On VC1, VC2, VCL, VF1, and VFL units operating with a remote sump tank and all VT1 and VTL units, install a bleed line with valve between the system circulating pump discharge riser and a convenient drain. Locate the bleed line in a portion of the riser piping that drains when the pump is off. VC1, VC2, VCL, VF1, and VFL units that are furnished with a factory-installed circulating pump include a bleed line with valve.

CAUTION: The bleed valve should always be open when the unit is in operation, unless the bleed rate is automatically controlled by a water treatment system. Recommended bleed rates may be found in the Operating and Maintenance Manual.

16. INSTALLATION OF FAN HOUSING CLOSURE PANELS
(FOR VC1-C MODELS ONLY)

After removing temporary covers, apply layer of 1" butyl sealer tape sealer along the perimeter of the fan housing wrapper opening and on the flanges of the fan housing panel. Next, tuck bottom flange of fan housing closure panel behind lower fan housing wrapper and attach with 5/16" hardware. Fill all open gaps and seams with caulk (see Figure 5).

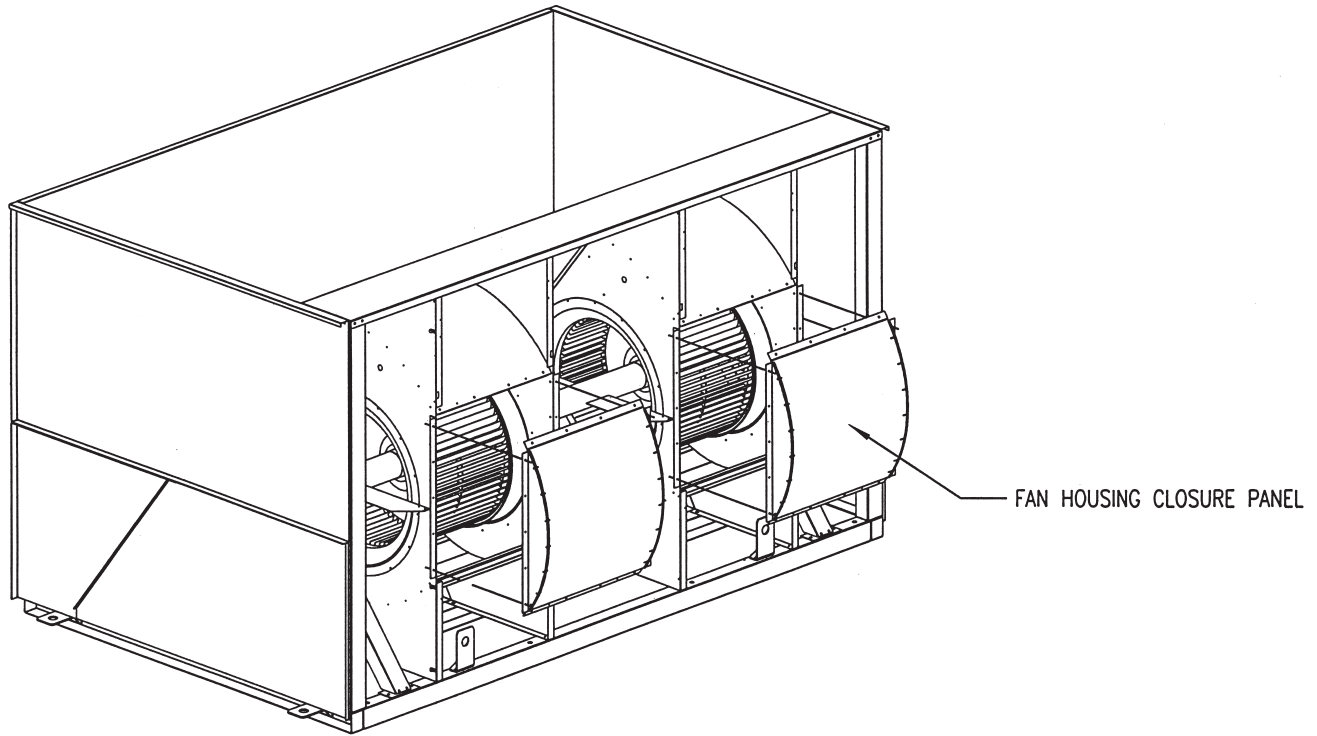

Figure 5



Baltimore Aircoil Company

P.O. Box 7322, Baltimore, Maryland 21227
410-799-6200 Fax 410-799-6416

Layout Guidelines

Open circuit cooling towers, closed circuit cooling towers, and evaporative condensers all depend upon an adequate supply of fresh, ambient air to provide design capacity. Other important considerations such as the proximity to building air intakes or discharges also must be taken into account when selecting and designing the equipment site. Included are the design layout guidelines for evaporative cooling products in several situations typically encountered by designers. These guidelines represent minimum spacing requirements; more open spacing should be utilized whenever possible.

As the size of an installation increases, the total amount of heat being rejected to the atmosphere and the volume of discharge air increase -- to the point where the units can virtually create their own environment. As a result, it becomes increasingly difficult to apply a set of general guidelines for each case. Such installations, and particularly those in wells or enclosures, will recirculate and the problem becomes one of controlling the amount of recirculation and/or adjusting the design wet-bulb temperature to allow for it. Consequently, any job that involves four or more cells should be referred to your local BAC Representative for review.

Axial fan equipment units are not generally suited for indoor or ducted applications. In such situations, a Series V centrifugal fan unit is recommended.

General Considerations:

When selecting the site for a cooling tower, closed circuit cooling tower, or an evaporative condenser, consider the following factors:

1. Locate the unit to prevent the warm discharge air from being introduced into the fresh air intakes of the building(s) served by the unit, intakes of neighboring buildings, or from being carried over any populated area such as a building entrance.
2. Consider the potential for plume formation and its effect on the surroundings, such as large windowed areas, and pedestrian or vehicular traffic arteries, particularly if the unit(s) will be operated during low ambient temperatures.
3. Provide sufficient unobstructed space around the unit(s) to ensure an adequate supply of fresh, ambient air to the air intake. Avoid situations that promote recirculation of unit discharge air, such as units located:
 - a. Adjacent to walls or structures that might deflect some of the discharge airstream back into the air intake.
 - b. Where high downward air velocities in the vicinity of the air intake exist.
 - c. Where building air intakes or exhausts, such as boiler stacks in the vicinity of the unit, might raise the inlet wet-bulb temperature or starve the unit of air.
4. Provide adequate space around the unit for piping and proper servicing and maintenance, as shown in Figure 1, 2, and 3.



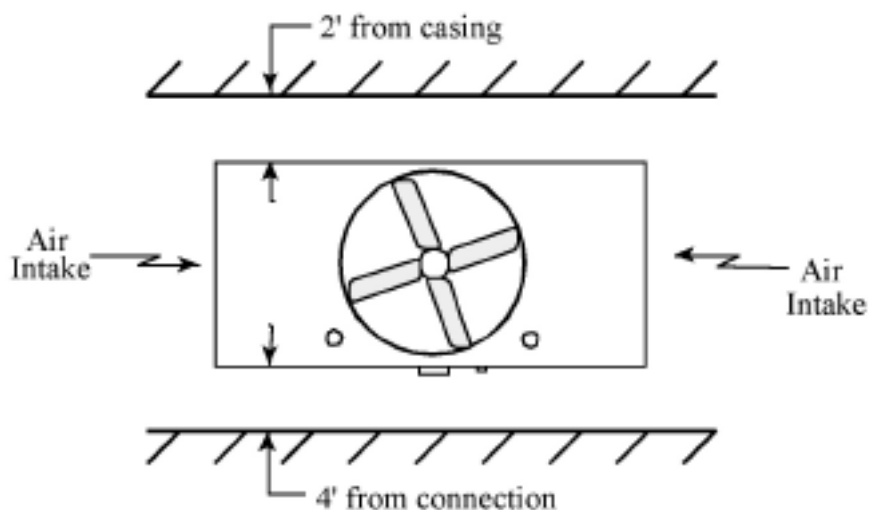

Figure 1: Plan view of recommended unit servicing and maintenance spacing for dual air inlet unit (Series 3000 Cooling Towers, FXV-288 & 364 Closed Circuit Cooling Towers, CXV-T Evaporative Condensers)

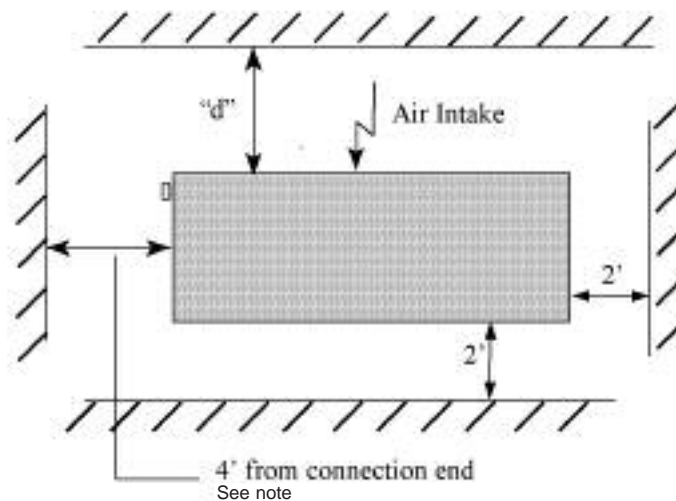

Figure 2: Plan view of recommended unit servicing and maintenance spacing for single air inlet unit (Series 1500 Cooling Towers, FXV Closed Circuit Cooling Towers, CXV Evaporative Condensers, Series V Cooling Towers, Closed Circuit Cooling Towers and Evaporative Condensers)

Note: On Models VT0-12 through 176, VC1-10 through 205, VF1-009, 018, 027, 036, and VF1-048 clearance equal to the length of the unit should be provided on one end to facilitate fan shaft removal.

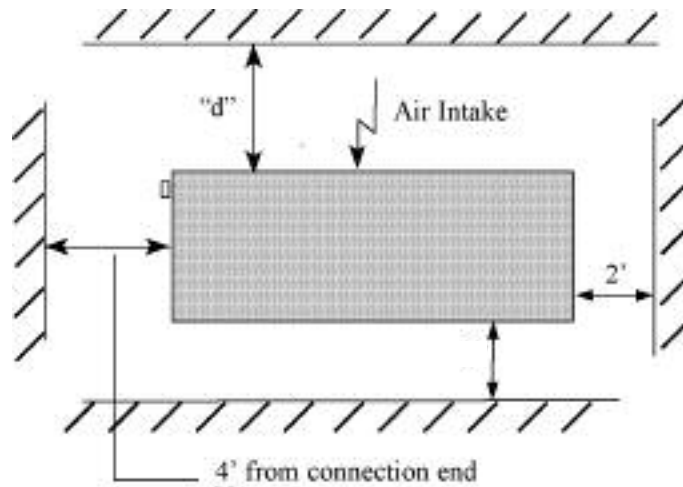

Figure 3: Plan view of recommended unit servicing and maintenance spacing for single air inlet unit (FXT Cooling Towers)

5. The top of the fan discharge cylinder, velocity recovery stack, or discharge sound attenuation must be at least level with, and preferably higher than any adjacent walls or buildings.
6. When possible, orient the unit so the prevailing summer wind blows the discharge air away from the air intakes of the unit(s).
7. When the unit is installed with intake sound attenuation, the distances given in the tables below should be measured from the face of the intake sound attenuation.
8. On larger unit installations, the problem of ensuring an adequate supply of fresh, ambient air to the tower intakes becomes increasingly difficult. See the "Multi-cell Installations" Section of this article for specific considerations.
9. If the installation does not meet the recommended guidelines, the units will have a greater tendency to recirculate and the design conditions should be altered to include an allowance for the recirculation. For instance, if the design conditions are 95°F/85°F/78°F and it was estimated that the allowance for recirculation rate was 1°F, then the new design conditions would be 95°F/85°F/79°F and the units should be reselected based on the new design conditions.

The "Layout Guidelines" describe several typical site layouts for BAC's cooling towers, closed circuit cooling towers, and evaporative condensers. If these guidelines do not cover a particular situation or if the layout criteria cannot be met, please refer the application to your BAC Representative for review. Please indicate prevailing wind direction, geographic orientation of the unit(s), and other factors such as large buildings and other obstructions that may influence layout decisions.





Layout Guidelines:

1. Unit Orientation

When a unit is located near a building wall, the preferred arrangement is to have the cased end or blank-off side (unlouvered side) facing the adjacent wall or building.

2. Air Inlet Requirements:

Should it be necessary to install a unit with the air intake facing a wall, provide at least distance "d" between the air intake and the wall, as illustrated in Figures 4a and 4b.

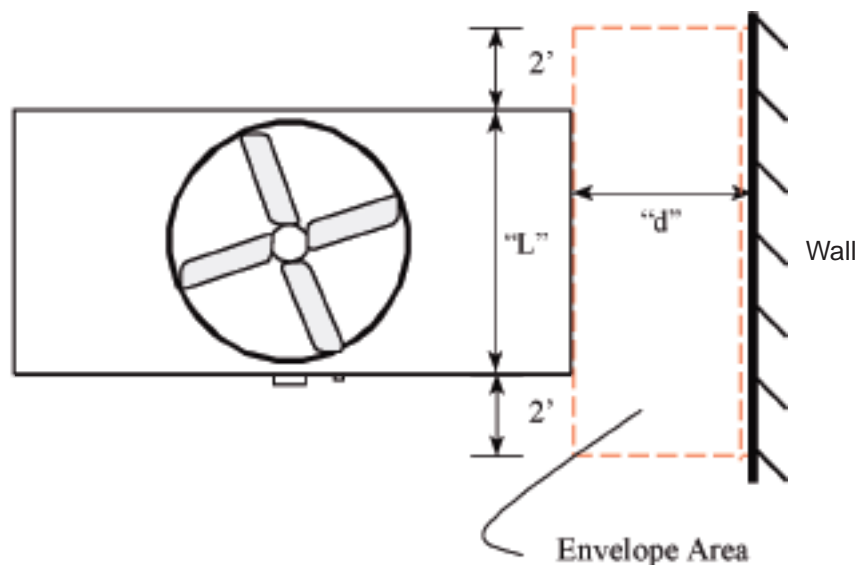

Figure 4a: Plan view of unit adjacent to a wall

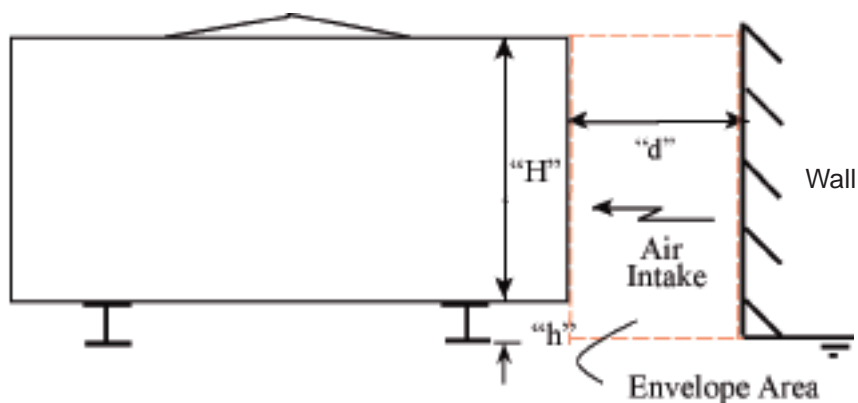

Figure 4b: Section view of unit adjacent to a wall

Below is the method for determining the minimum acceptable dimension "d" for a unit located with the air intake facing a solid wall:

The maximum acceptable envelope air velocity for all products except Series V with tapered hood is 300 FPM, as illustrated in the following equation:

$$\text{Envelope Velocity} = \frac{\text{Unit Airflow}}{\text{Envelope area}} < 300 \text{ FPM}$$

For Series V units with a tapered hood the maximum acceptable air velocity increases to 400 FPM as illustrated in the following equation:

$$\text{Envelope Velocity} = \frac{\text{Unit Airflow}}{\text{Envelope area}} < 400 \text{ FPM}$$

NOTE: The louver face CFM for the FXV Closed Circuit Cooling Towers and CXV Evaporative Condensers is 70% of the total unit airflow. The remaining 30% of the airflow entering the unit through the top of the coil section.

The Envelope area as illustrated on Figures 4a & 4b is $[(L + 2 + 2) \times d] + 2(H + h) \times d$, where:

"H" - height of the air intake face in feet

"h" - elevation of the unit from the roof/ground/pad in feet. The maximum elevation is 4 feet.

"L" - length of the air intake in feet

"d" - minimum acceptable distance between the wall and the air intake face in feet

The minimum acceptable dimension "d" for the products is tabulated in Table 1. **The distance "d" was calculated using the largest horsepower model in the box size.**

Example: Model 31132A-3 Adjacent to a Solid Wall

What is the minimum distance required between the air inlet of the 31132A-3 when installed facing a wall?

Unit Airflow = 267,880 CFM x 3 cells = 803,640 CFM

H = 18' 1-1/2" (18.1')

h = 0'

L = 42' 2-3/8" (42.2')

300 FPM = maximum acceptable envelope air velocity for a cooling tower

$$\text{Envelope Velocity} = (\text{Unit Airflow}) / (\text{Envelope Area})$$

solving for "d",

$$300 \text{ FPM} = (803,640 \text{ CFM} / 2 \text{ air intake sides}) / [((42.2+4) \times d) + 2(18.1+0) \times d]$$

$$d \times (82.4) = (401,820 \text{ CFM}) / (300 \text{ FPM})$$

$$d = [(401,820 \text{ CFM}) / (300 \text{ FPM})] / 82.4$$

$$d = 16.25 \text{ feet}$$

This is rounded up to the next 0.5' increment. Therefore, the air intake should be located no less than 16.5 feet from the solid wall.





Example: VT1-415-R adjacent to a wall

What is the minimum distance required between the air inlet of the VT1-415-R when installed facing a wall?

Solution:

Unit Airflow = 90,250 CFM

H = 8'4" (8.33')

h = 0'

L+6' = 11' 7-3/4"+6' (17.65')

300 FPM = maximum acceptable envelope air velocity with no hood.

Solving for "d"

$$d = \frac{\text{Unit Airflow}}{300 \times [2(H + h) + (L + 6)]}$$

$$d = \frac{90,250 \text{ cfm}}{300 \text{ fpm} \times [2(8.33' + 0') + (11.65' + 6')]}$$

d = 9' rounded

Therefore, the air intake should be no less than 8.0 feet from the wall.

Minimum Acceptable Air Inlet Distance "d" (feet) to Solid Wall

Table 1: Series 3000

Elevation	One Cell			Two Cell			Three Cell			Four Cell		
	0'	2'	4'	0'	2'	4'	0'	2'	4'	0'	2'	4'
Series 3000 Model												
3240A to 3299A	4.5	4	3.5	6.5	6	5.5	8	7.5	7	9.5	9	8
3333A to 3379A	5	4.5	4	8	7	6.5	9.5	9	8.5	11	10.5	9.5
3412A to 3436A	5.5	5	4.5	8	7.5	7	10	9.5	9	1.5	11	10
3455A to 3527A	6	5.5	5	9	8.5	8	11.5	10.5	10	13	12	11.5
3473A to 3501A	6	5.5	5	8.5	8	7.5	10.5	10	9.5	14.5	11	10.5
3552A to 3672A	7	6.5	6	11	10	9.5	13	12.5	11.5	14.5	14	13.5
3728A to 3828A	7	6.5	6	11.5	10.5	10	14	13.5	13	16	15.5	15
3872A to 3970A	7.5	7	6.5	12	11	10.5	15	14	13.5	17	16.5	16
3985A to 31056A	7	6.5	6.5	11.5	11	10.5	15	14.5	13.5	17.5	16.5	16
3583A to 3725A	7	6.5	6	10.5	10	9.5	13	12	11.5	14	13.5	13
331132A	8	7.5	7	13	12	11.5	16	15.5	14.5	18	17.5	17
31213A to 31301A	8.5	8	7.5	13.5	13	12.5	17	16	15.5	19.5	19	18

Table 10: VC2

Unit Elevation	No Discharge Hood		
	0'	2'	4'
VC2-N138 to N191	5	4	3.5
VC2-N206 to N235	5.5	4.5	4
VC2-N261 to N301	6.5	5.5	5
VC2-N356 to N446	8.5	7.5	6.5
VC2-319 to 626	8.5	7.5	7
VC2-526 to 957	12.5	11.5	10.5
VC2-N870 to N1204	17.5	15.5	14.5
VC2-684 to 1252	17	15	14
VC2-1052 to 1914	25	22.5	20

Table 11: VCL/ VFL

Unit Elevation		No Discharge Hood			4' Discharge Hood		
		0'	2'	4'	0'	2'	4'
VCL-016 to 035	VFL-012-XXX	3	3	3	3	3	3
VCL-038 to 079	VFL-024-XXX	3	3	3	3	3	3
VCL-087 to 120	VFL-036-XXX	4.5	3.5	3	3	3	3
VCL-134 to 155	VFL-048-XXX	4.5	4	3.5	3.5	3	3
VCL-167 to 234	VFL-072-XXX	6	5.5	5	4.5	4	3.5
VCL-257 to 299	VFL-096-XXX	7	6.5	5.5	5.5	5	4.5

Well Layout

The following method is used to determine the minimum acceptable dimension "d" for units installed in a well layout.

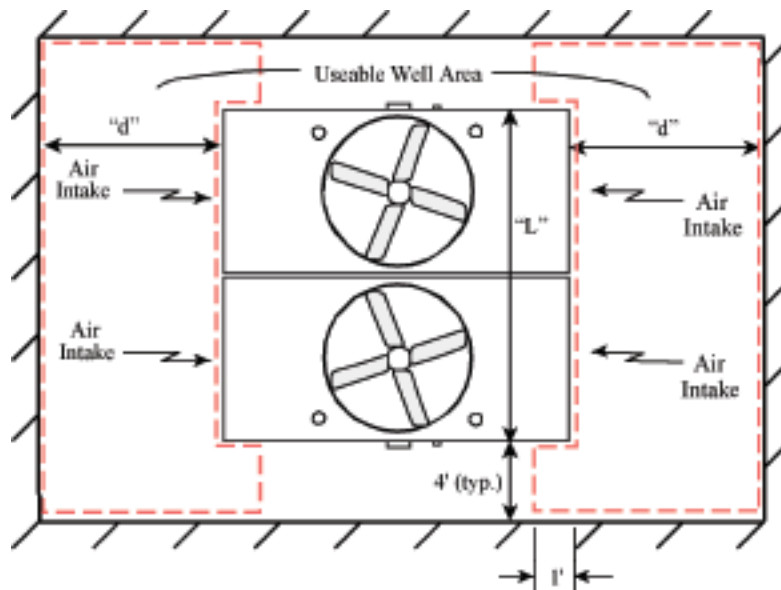

Figure 5: Plan view of dual air inlet units in a well enclosure

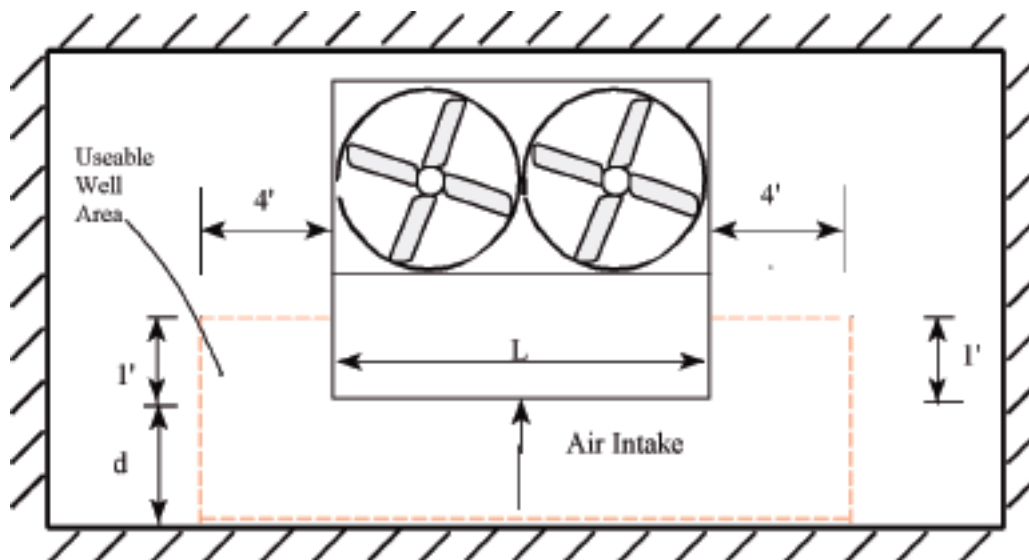

Figure 6: Plan view of single air intake units in a well enclosure

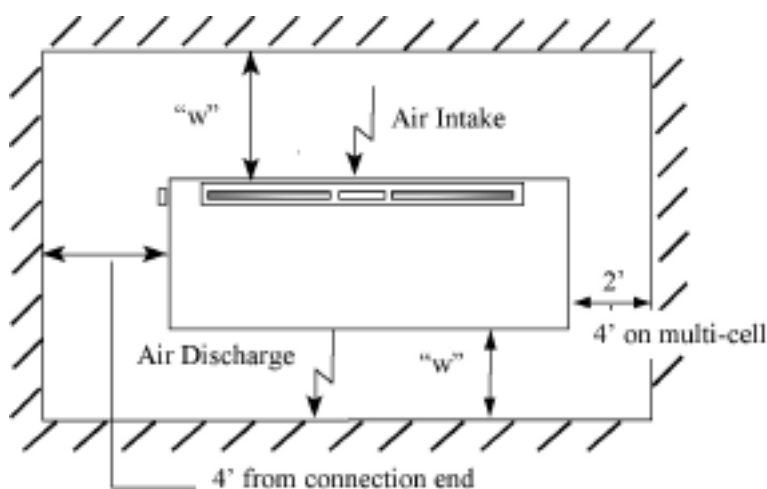

Figure 7: Plan view of single air intake & horizontal discharge units in a well enclosure

The maximum allowable downward air velocity for a well installation is 400 fpm. The downward velocity is determined using the following equation:

$$\text{Downward Air Velocity} = \frac{\text{Unit Airflow}}{\text{Useable Well Area}} < 400 \text{ fpm}$$

NOTE: The louver face CFM for the FXV Closed Circuit Cooling Towers and CXV Evaporative Condensers is 70% of the total unit airflow. The remaining 30% of the airflow entering the unit through the top of the coil section.

The usable well area at each air intake face is defined as illustrated in Figure 5 & 6.

Useable Well Area = $[(d)(L+4'+4')] + [(4' \times 1') + (4' \times 1')]$, where

- "d" - minimum acceptable distance between the air intake of the unit and the wall of the well in feet
- "L" - length of the air intake of the unit in feet.

The minimum acceptable distance "d" for well installations is tabulated in Table 2.

Example: Model 3672A-2 in a well

Unit Airflow = 166,020 CFM x 2 cells = 332,040 CFM

L = 23'-10" (23.8')

400 fpm = maximum allowable air downward velocity for a cooling tower

Downward Air Velocity = (Unit Airflow) / (Useable Well Area)

solving for "d",

$$\begin{aligned} 400 \text{ fpm} &= (332,040 \text{ CFM} / 2 \text{ air intake sides}) / [(d)(23.8+4+4)]+(4+4) \\ [(d)(31.8)]+(8) &= (166,020 \text{ CFM}) / (400 \text{ FPM}) \\ d &= [((166,020 \text{ CFM}) / (400 \text{ FPM}))-8] / 31.8 \\ d &= 12.8 \text{ feet} \end{aligned}$$

This is rounded up to the next 0.5' increment. Therefore, the air intakes should be no less than 13.0 feet from the enclosure walls.

Example: Model FXV-443 in a Well

Unit Airflow = 65,450 CFM

L = 12'-1" (12.104')

400 fpm = maximum allowable air downward velocity for a cooling tower

Downward Air Velocity = (Unit Airflow) / (Useable Well Area)

solving for "d",

$$\begin{aligned} 400 \text{ FPM} &= (65,450 \text{ CFM}) / [(d)(12.1+4+4)]+(4+4) \\ [(d)(20.1)]+(8) &= (65,450 \text{ CFM}) / (400 \text{ FPM}) \\ d &= [((65,450 \text{ CFM}) / (400 \text{ FPM}))-8] / 20.1 \\ d &= 7.7 \text{ feet} \end{aligned}$$

This is rounded up to the next 0.5' increment. Therefore, the air intake should be no less than 8.0 feet from the enclosure walls.

Example: VF1-144-31Q

If the VF1-144-31Q has a 4' tapered discharge, what is the minimum distance between the air inlet of the VF1-144-31Q in a well?

cfm = 86,500 cfm per cell.

Length = 11'-7 3/4" (11.65')

400 fpm = maximum allowable downward velocity for a VF1 with tapered hood

$$\begin{aligned} 400 \text{ fpm} &= (86,500 \text{ cfm}) / [d (11.65 + 4 + 4)] + (4 + 4) \\ [d(19.65)] + 8 &= (86,500 \text{ cfm}) / (400 \text{ fpm}) \\ d &= [((86,500 \text{ cfm}) / (400 \text{ fpm})) - 8] / 19.65 \\ d &= 10.59 \text{ feet} \end{aligned}$$

This is rounded up to the next 0.5' increment. Therefore the air intake should be no less than 11 feet from the enclosure walls.



Table 17: CXV / FXV

		One Cell	Two Cell
CXV 64 to 95	FXV-42X	4	6
CXV 103 to 153	FXV-43X	5.5	7.5
CXV 160 to 206	FXV-44X, Q44X	6.5	8
CXV 196 to 305	FXV-64X, Q64X	8.5	10.5
CXV 310 to 481	FXV-66X, Q66X	10	12
CXV 420 to 610		-	10.5
CXV 620 to 962		-	12
CXV N465 to N687		11.5	-

Table 18: CXV-T / FXV-3

		One Cell	Two Cell
CXV T645 to T792	FXV-288-XXX	9.5	12.5
CXV T791 to T944	FXV-364-XXX	11	14
CXV T1290 to T1584		12.5	-
CXV T1582 to T1888		14	-

Table 19: VC1 / VF1

		With or Without a Tapered Discharge Hood
VC1-10 to 25	VF1-009-XXX	3
VC1-30 to 65	VF1-018-XXX	3
VC1-72 to 90	VF1-027-XXX	3
VC1-100 to 135	VF1-036-XXX	3
VC1-150 to 205	VF1-048-XXX	4.5
VC1-N208 to N230	VF1-072-XXX	6.5
VC1-N243 to N315	VF1-096-XXX	8
VC1-N338 to N470	VF1-144N-XXX	7.5
----	VF1-192-XXX	10
----	VF1-288N-XXX	9
VC1-386 to 516	VF1-144-XXX	11.5
VC1-540 to 804	VF1-216-XXX	14
VC1-772 to 1032	VF1-288-XXX	13.5
VC1-1158 to 1608	VF1-432-XXX	16.5
VC1-C216 to C320	----	8.5
VC1-C339 to C469	----	11.5

Table 20: HXV

	One Cell
HXV-64X	7
HXV-66X	8.5

Table 21: VC2

	One Cell
VC2-N138 to N191	5.5
VC2-N206 to N235	6.5
VC2-N261 to N301	7.5
VC2-N356 to N446	11
VC2-319 to 626	10.5
VC2-526 to 957	15.5
VC2-N870 to N1204	22
VC2-684 to 1252	21
VC2-1052 to 1914	31.5

Table 22: VCL / VFL

		With or Without a Tapered Discharge Hood
VCL-016 to 035	VFL-012-XXX	3
VCL-038 to 079	VFL-024-XXX	3
VCL-087 to 120	VFL-036-XXX	5.5
VCL-134 to 155	VFL-048-XXX	6
VCL-167 to 234	VFL-072-XXX	8
VCL-257 to 299	VFL-096-XXX	9





Louvered Well Installation

Check to see if the layout meets the requirements for a well installation. If the criteria for the well installation are met, the layout is satisfactory. If the layout does not satisfy the criteria for the well installation, analyze the layout as follows:

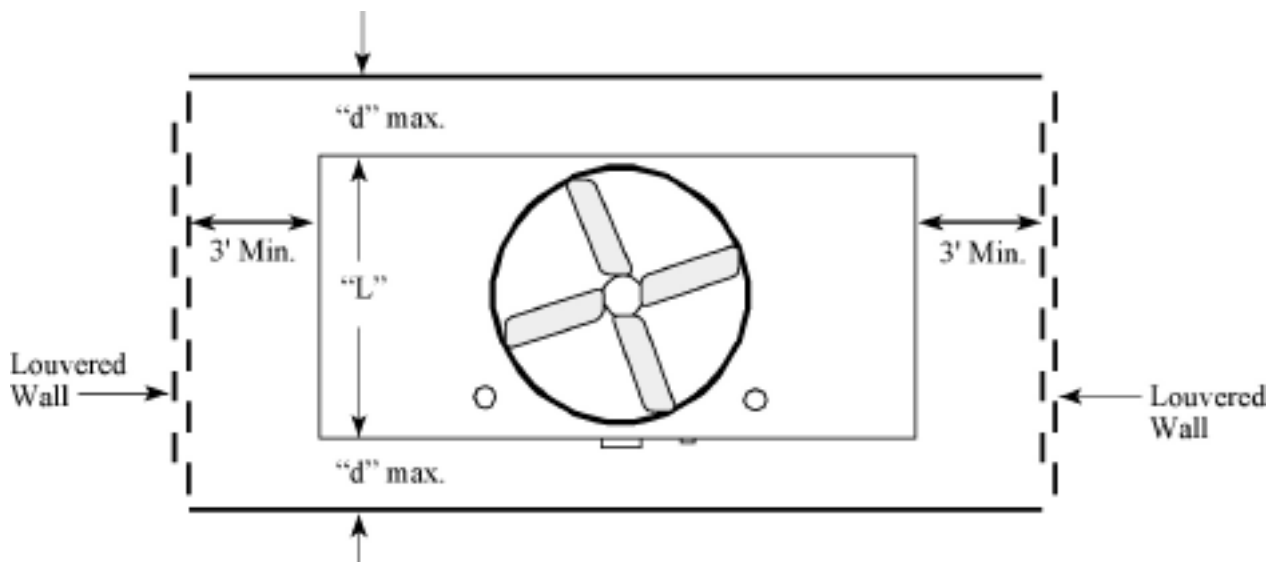

Figure 8: Plan view of a dual air intake unit in enclosure with louvered walls

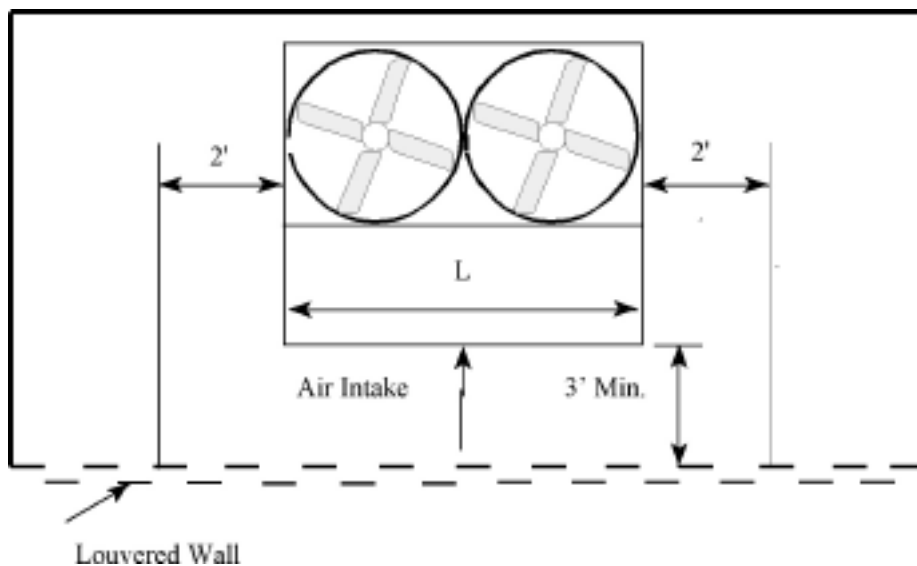

Figure 9: Plan view of a single air intake unit in enclosure with louvered walls

1. Air intake requirements:

Units should be arranged within the enclosure such that:

- a. The air intake directly faces the louver or slot locations as shown in Figure 8 or 9.
- b. Maintain a distance of at least three feet (3'-0") between the unit air intake(s) and the louvered or slotted wall for uniform air distribution.

- c. If the available space does not permit the unit can be arranged with the air intakes facing the louvered or slotted walls and the enclosure cannot be modified to permit such an arrangement, consider the alternative illustrated in Figure 10 or 11. This arrangement should be restricted to one-cell or two-cell installations. The effective area of the louvers is only the length extending beyond the width of the tower.

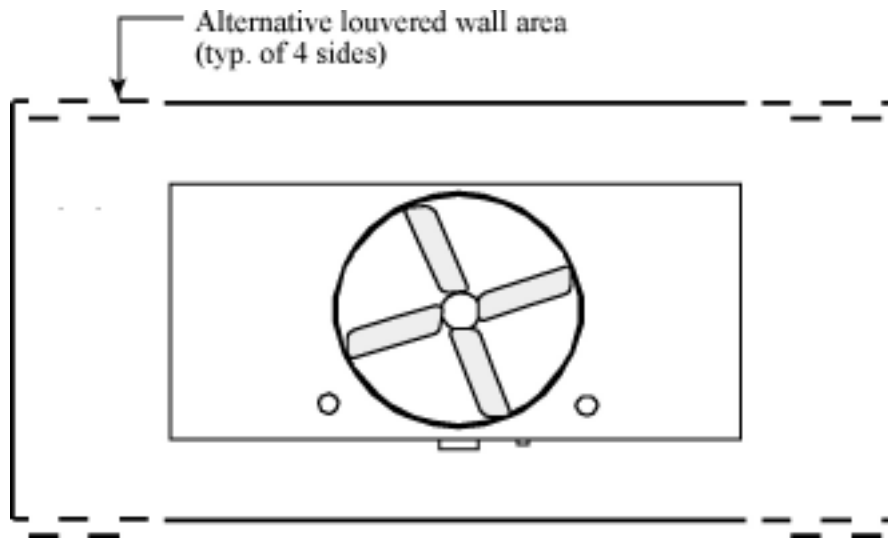

Figure 10: Plan view of dual air inlet unit in enclosure with alternate louver arrangement

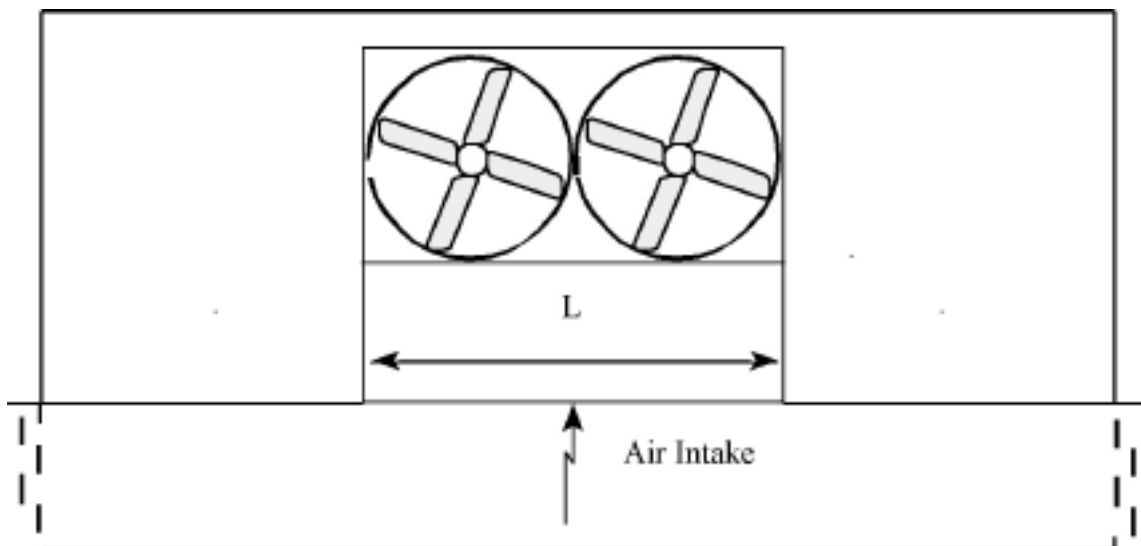

Figure 11: Plan view of single air inlet unit in enclosure with alternate louver arrangement

2. Louver Requirements:

- Louvers must provide at least 50% net free area to ensure that the unit airflow is not reduced due to friction or dynamic losses and that sufficient air is drawn through the openings and not downward from above.
- The required total louver or slot area is based on drawing the total unit airflow through the net free area of the louvers at a velocity of 600 FPM or less.
- Locate the louver area in the walls of the enclosure such that air flows uniformly to the air intakes.



- d. If the unit is elevated to ensure the discharge is at the same level or above the top of the enclosure, it is acceptable to extend the louvered or slot area below the base of the units up to 2 feet if needed to achieve the minimum gross louver area. To calculate air velocity through the louver, the useable louvered or slot area may extend beyond the ends of the unit, by 4' maximum

Calculate the louver velocity as follows:

$$\text{Louver Velocity} = \frac{\text{Total Unit Airflow (CFM)} < 600 \text{ fpm}}{\% \text{ Louver Free Area} \times \text{Useable Louver Area (sq ft)}}$$

Example: 3473A-2 in a Louvered Enclosure

The enclosure is 27.5' long x 38' wide x 10' tall. The enclosure walls are equal in elevation to the unit discharge height. The louvers are 70% free area and 3'-0" from the air inlet of the tower. The louvers extend the full width of the enclosure (38') on both air intake ends and they extend 9' vertically of the 10' enclosure height.

Unit Airflow = 118,870 CFM x 2 cells = 237,740 CFM

Unit "L" Dimension = 11' 9-3/4" per cell x 2 cells = 23' 10" (23.83')

"d" max. = 4 feet per side

Useable Louver Length = 23.83' + 4' + 4' = 31.83 ft. (of total 38' louver length)

600 FPM = Maximum Allowable Louver Velocity

$$\begin{aligned} \text{Louver Vel.} &= \frac{\text{Louver Face Airflow (CFM)}}{[(\% \text{ Louver Free Area}) \times (\text{Use. Louver Area})]} \\ &= \frac{(237,740 \text{ CFM} / 2 \text{ intake sides})}{[(70\%) \times [(23.83' + 4' + 4') \times (9')]} \\ &= \frac{(118,870 \text{ CFM})}{(200 \text{ sq ft})} \\ &= 594 \text{ fpm} \end{aligned}$$

Therefore, louver sizing is sufficient because 594 FPM < 600 fpm maximum allowable.

Indoor Installation Layout Guidelines –

Applicable for Series V Centrifugal Fan Products Only (VT0, VT1, VTL, VF1, VC1)

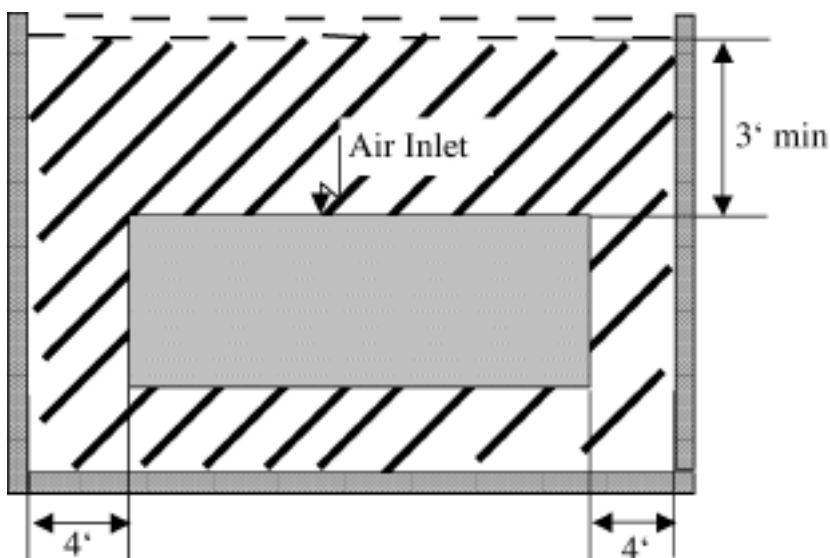

Figure 12: Plan view of unit enclosure with louvered wall & closed top installation

Air Inlet Requirements

- Louvers must have at least 50% net free area.
- Install the cooling tower with the limitations shown in Figure 12 for uniform air distribution.
- Determine the total louver or slot area required based on drawing the total unit cfm through the net free area of the louvers at a velocity of 800 fpm or less.
Calculate the louver velocity as follows:
- The louver or slot area should be located in the walls of the enclosure so that air flows uniformly to all air inlets.
- It is acceptable to extend the louvered or slot area below the base of the unit if needed to achieve the minimum gross free area. The usable or slot area may also be extended beyond the ends of the tower by 4'.
- As a general rule, Series V Multi-Stage Axial Fan Models cannot be located indoors.

Ductwork Requirements

- Air velocities in the inlet duct should be kept below 800 FPM to hold static pressure losses to a minimum and ensure a uniform supply of air to all fans. In general the maximum allowable ESP on Series V centrifugal fan units is 1/2". Consult the factory for any ESP greater than 1/2".
- Air velocities in the discharge duct(s) should not exceed 1,000 fpm to reduce friction losses in the duct, and more importantly, to ensure uniform air through the unit.
- Turns in inlet or discharge ducts should be avoided. Where turns must be used, velocities should be minimized in the vicinity of the turn. Turns in discharge ducting should be designed in accordance with the "2/3's rule" shown in Figure 13 a & b.
- Where individual fan sections are to be cycled for capacity control, each fan section must be ducted as a separate system on both inlet and discharge to avoid recirculation within the ductwork. All ductwork systems should be symmetrical to ensure that each fan section operates against the same ESP.
- Access doors must be provided in both the inlet and discharge ducts.
- When multi-cell units are located indoors with the room as a plenum, the installation must be operated as a single unit to avoid pulling air through an idle cell.

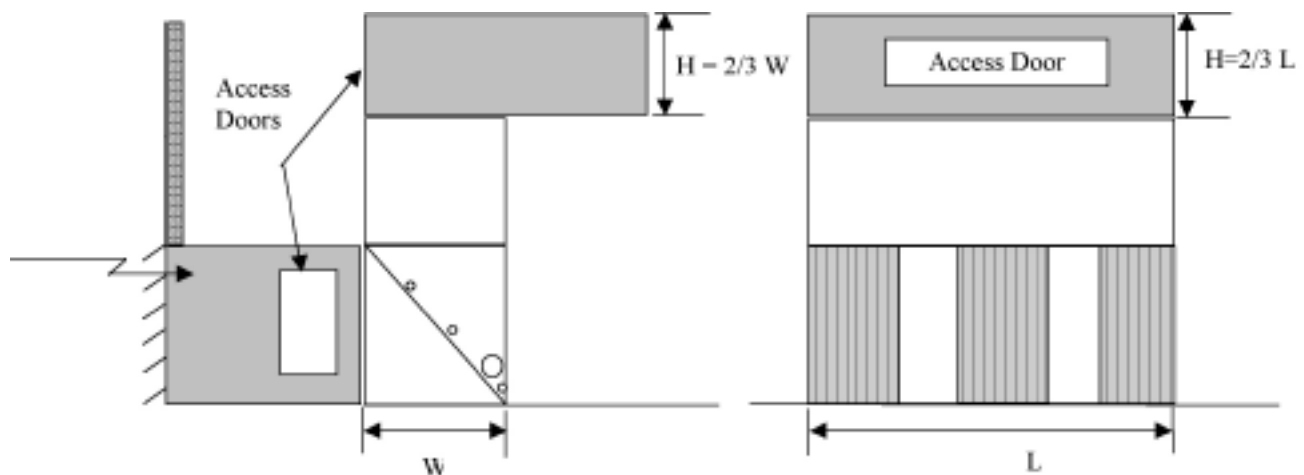

Figure 13 a & b: Section & front view of ducted unit enclosure





Multi-cell Installations

Multiple cells create a "wall" of moist discharge air which could easily be swept into the air intakes due to prevailing wind. To minimize the potential of recirculation of the discharge air, the units should be situated with adequate spacing between air intakes.

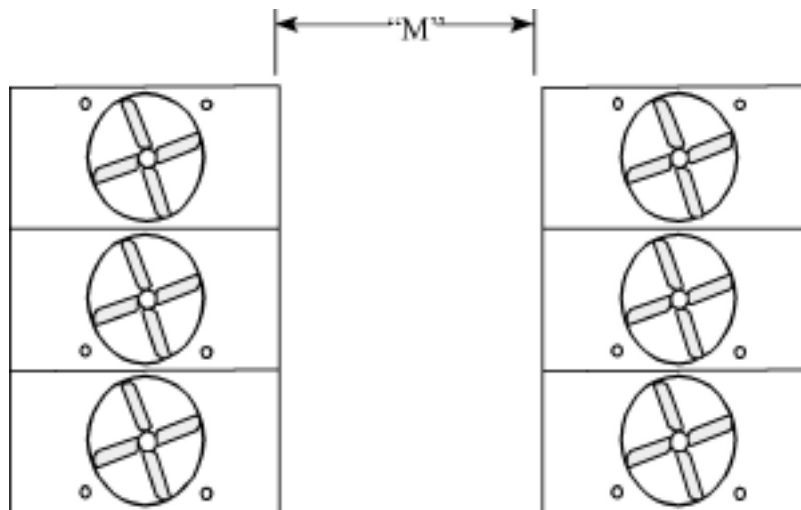

Figure 14: Plan view of multi-cell units with air intakes facing each other

When multiple cells are arranged with the air intakes facing each other, the distance between air intakes should follow the equation below:

$M = (2 \times d) + (\text{number of cells per module})$, where "d" is obtained from the appropriate model in Section A, Table 1.

Example: Model 2-3985A-3

There are two modules of three cells of units on a roof. There are no enclosures surrounding the unit installation. The two banks of units have air intakes facing each other. The minimum distance "M" between rows of units is determined as follows:

from Table 1, "d" = 15.5',

$$\begin{aligned} M &= (2 \times d) + (\text{number of units per module}) \\ &= (2 \times 15.5) + (3) \\ &= 34 \text{ feet} \end{aligned}$$

The calculated "M" dimension of 34 feet will minimize the potential of recirculation of the discharge air.

Group the units in two cell or three cell groups, spaced at least one unit length between adjacent end walls to allow fresh air to circulate around each group, as shown in Figure 15.

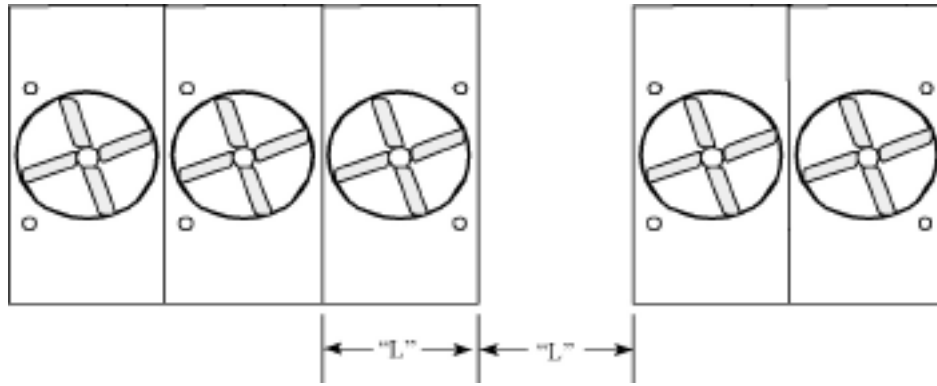

Figure 15: Plan view of recommended multi-cell installation

In the extreme case, when multiple cells are arranged with the air inlets facing each other in a well, the dimensions between the cells should follow the following requirements.

1. Enclosure: The bottom 3 feet of the well should be louvered a minimum of 50% net free area to allow air flow under the units as shown in Figure 17.
2. Support: The units should be raised off the roof deck to allow fresh air to flow under to the air inlets between the bank of cells.
3. The distance between the cells should be determined using the following method.

- a. Determine the maximum airflow drawn from the louvered area using the following equation:

CFM drawn through the louvers = Louver Velocity x % Louver Free Area x Useable Louver Area

CFM drawn through the louvers = 800 FPM x % Louver Free Area x Useable Louver Area

- b. Determine the CFM drawn from the top of the enclosure using the following equation:

CFM drawn from the top of the enclosure = Downward Velocity x Useable Well Area

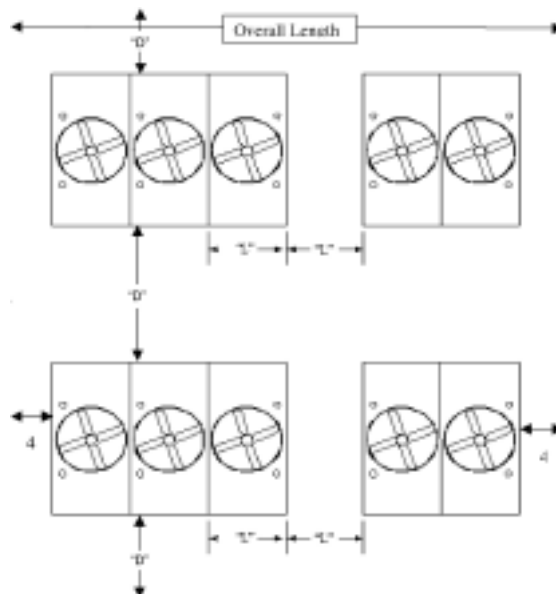

Figure 16: Plan view of multi-cell installation

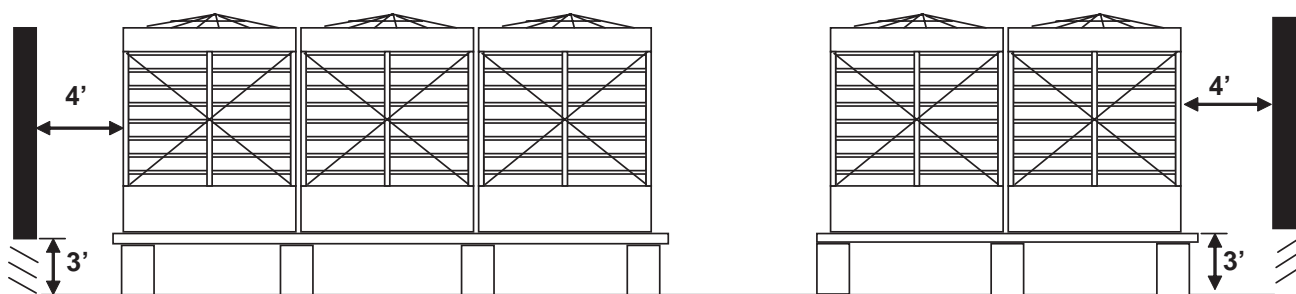

Figure 17: Elevation view of recommended enclosure

Example: (10) 31056A

For example, what is the minimum distance D between the banks of cells of a (10) 31056A?

Unit Airflow = 246,700 CFM x 10 cells = 2,467,000 CFM

Overall length of enclosure = Number of cells x L + Number of Openings x L + 4 + 4
 = 5 x 12 + 1 x 12 + 4 + 4
 = 80 feet

3' of 50% louvered around building with a louver velocity of 800 fpm

CFM Drawn through louvers = Louver Velocity x % Louver Free Area x Useable Louver Area
 = Louver Velocity x % Louver Free Area x Perimeter of the Enclosure x Height of Louvered Wall
 = Louver Velocity x % Louver Free Area x (2x (Overall Length + Overall Width) x Height of Louvered Wall
 = 800 x 0.5 x 2 x (80 + 4D) x 3
 = 192000 + 9600D

CFM Drawn from Top of the Enclosure = Downward Velocity x Useable Area

= Downward Velocity x 4D x (Overall Length)
 = 400 x 4D x Overall Length
 = 400 x 4D x 80
 = 128000D

CFM Drawn through louvers + CFM Drawn from Top of the Enclosure = Total CFM per Installation

192000 + 9600D + 128000 D = 2467000
 137600 D = 2467000 - 192000
 137600 D = 2275000
 D = 16.533

The "Layout Guidelines" describe several typical site situations involving evaporative cooling products. If these guidelines do not cover a particular situation or if the layout criteria cannot be met, please refer the application to the your local BAC Representative for review. Please indicate prevailing wind direction, geographic orientation of the unit(s), and other factors such as large buildings and other obstructions that may influence layout decisions.