

Girton Pallet Washer

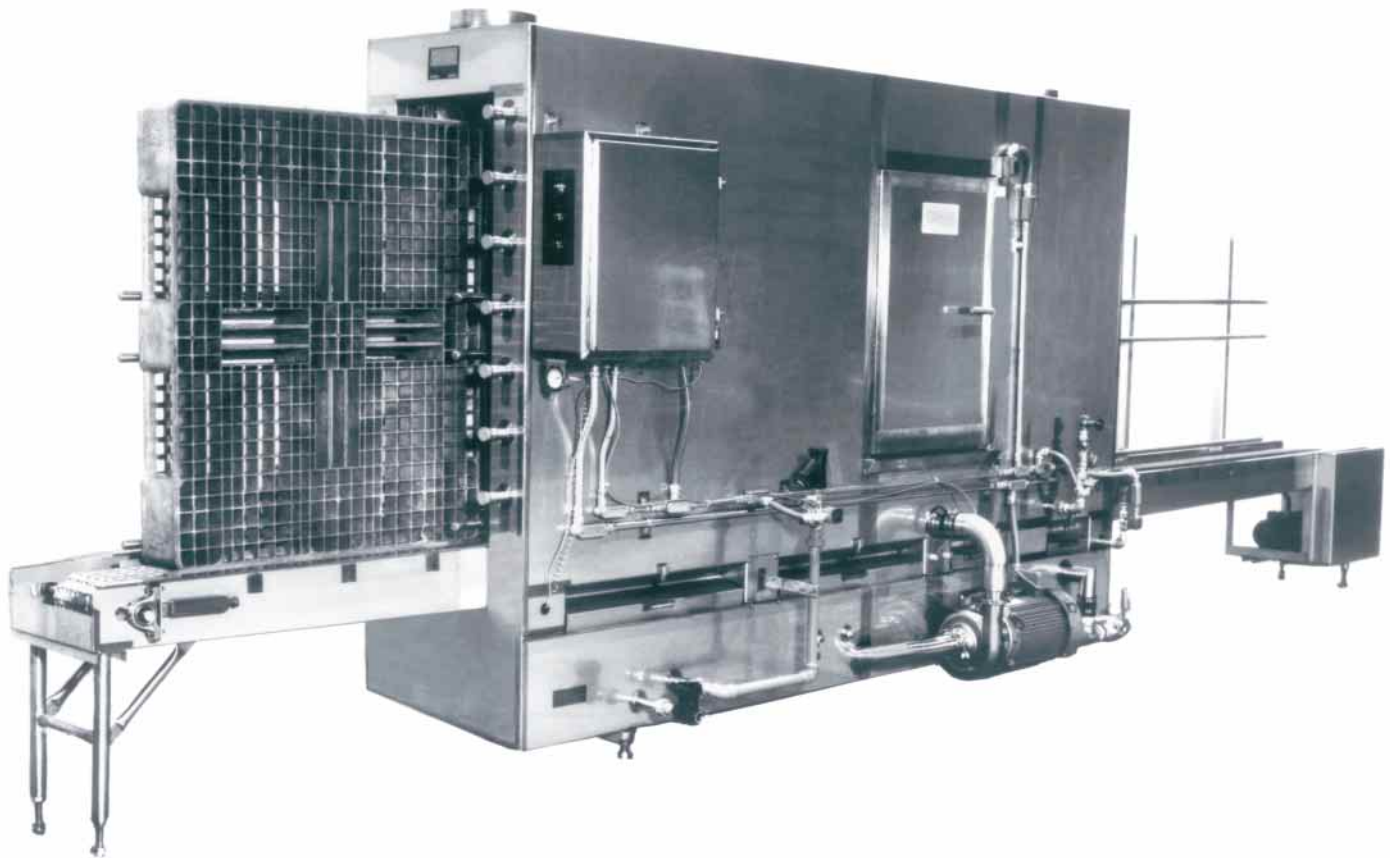

Features:

- All stainless steel construction
- Variable-speed conveyor — to carry pallets thru the washer in a vertical position
- 3 screens to protect pump and jets
- 10HP wash pump delivers 350GPM at 80' head pressure
- Fresh rinse header using water from plant supply
- Automatic steam temperature controls for wash
- Special jet design provides efficient cleaning
- 10" I.D. exhaust connections

Available Options:

- Stainless steel pump
- Air blow-off section — removes excess moisture from pallets
- Shut off switch for conveyor and fresh rinse when pallet is not removed



Girton

Girton Manufacturing Co., Inc.

P.O. Box 900 • Millville, PA 17846-0900

phone: 570.458.5521

fax: 570.458.5589

website: www.girton.com

e-mail: info@girton.com

Meeting the needs of the food industry since 1927.

Girton Pallet Washer

Dimensions

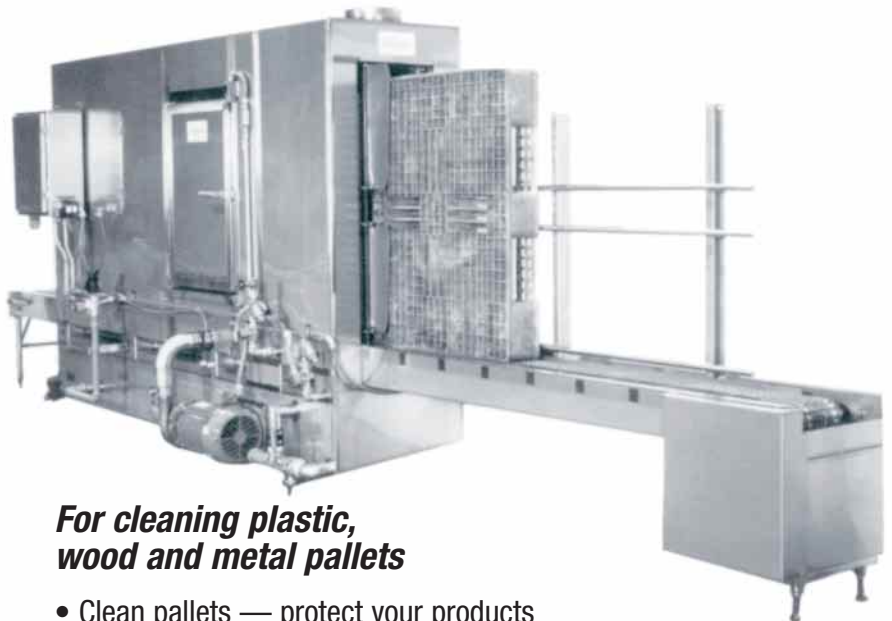
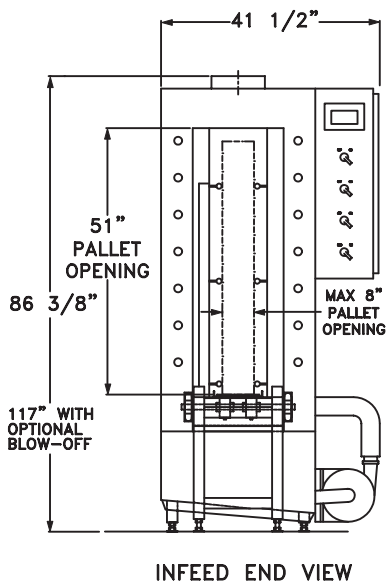
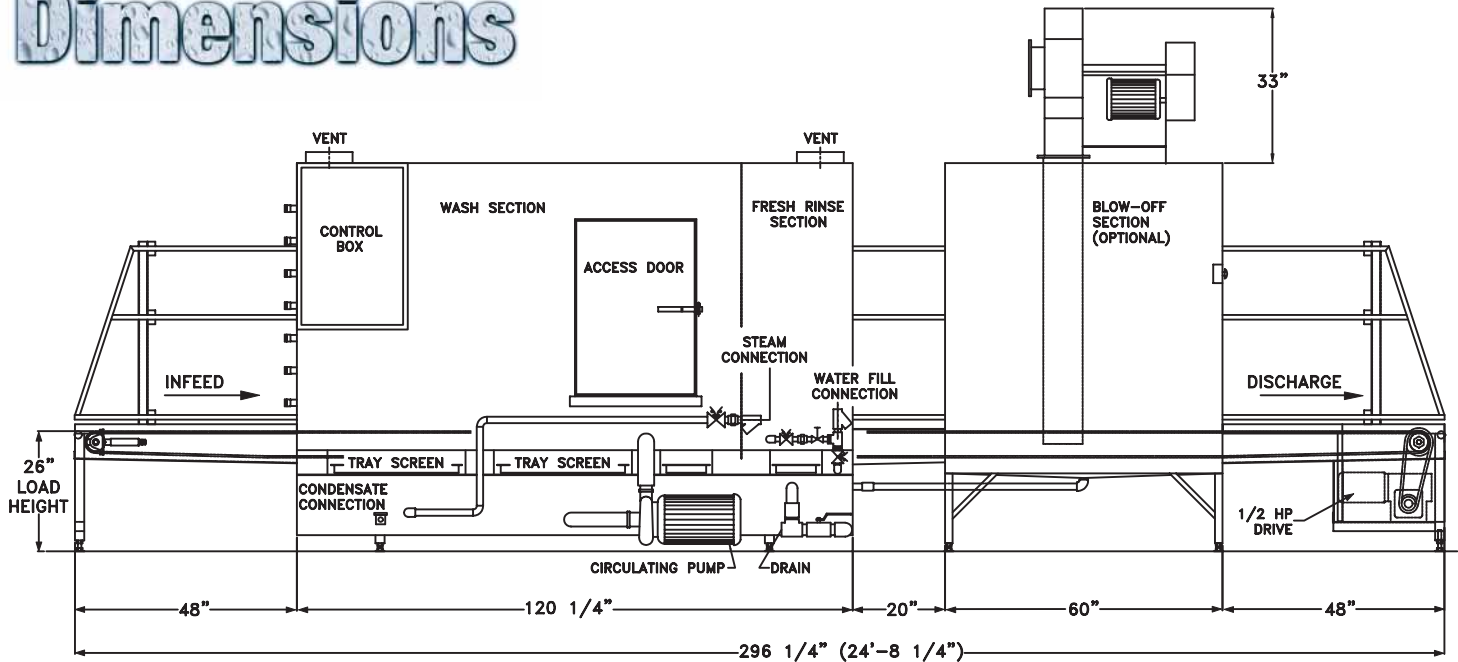

**For cleaning plastic,
wood and metal pallets**

- Clean pallets — protect your products
— extend pallet life — improve plant sanitation
- Clean 60 to 180 pallets per hour
- Completely assembled for easy installation, hook-up the water, steam and electrical — washer is ready to go

SPECIFICATIONS

GIRTON PALLET WASHER CW10PS Specification No. Document114

GENERAL

Girton CW-10PS Pallet Washer to wash and rinse plastic and wooden pallets up to 48" x 48" x 7-1/2" high at the rate of 60 to 180 per hour.

DIMENSIONS

Overall length - 18 ft., including 4 ft. infeed, 10 ft. wash and rinse section, and 4 ft. discharge.

Overall width - 42"

Overall height - 86" minimum

Load height - 26" minimum

Tunnel opening - 50" high x 8" wide

CONSTRUCTION

The tank, hull, infeed and discharge sections are fabricated of 14 gauge, type 304 stainless steel with 2B finish. All seams are welded and cleaned in a thorough manner. Guide rails, conveyor channels, piping and headers with jet spray deflectors are stainless steel.

CONVEYOR

The conveyor consists of stainless steel conveyor chain and is designed to convey the pallets through the washer in a vertical position. Conveyor speed can be increased to 12 feet per minute.

The conveyor will extend 4 ft. from the infeed and 4 ft. from the discharge ends of the washer, to facilitate loading and unloading the pallets. (Additional infeed and discharge conveyor is available as an option.)

Heavy duty stainless steel guide rails will support and guide the pallets through the washer.

DRIVE

1/2 Hp T.E.F.C. gearhead motor, arranged to carry the conveyor through the washer at a variable speed of 4 ft. to 12 ft. per minute.

SCREENS

Drawer type stainless steel tray screens will be used, with perforations smaller than the jet openings, to trap debris and protect the pump and spray orifices.

SIDE ACCESS DOOR

A hinged, latched and gasketed door is located on the service side of the washer. This feature allows access to the center of the washer for cleaning and inspection.

VENT

A 10" I.D. circular exhaust connection is provided on top of the washer at each end, to be connected to customer's exhaust system.

HEATING

See various heating options: Steam, Electric, Natural Gas.

RINSE

Rinse consists of a single spray loop spraying all outside surfaces at house temperature and pressure, controlled by hand operated valve.

THERMOMETER

The wash tank will be equipped with an indicating thermometer.

WASH PUMP

The 10 Hp. wash pump is cast iron stainless steel fitted, horizontal, close coupled motor mounted type, T.E.F.C., and is rated at 360 GPM at 70 ft. hd.

PIPING

Water piping shall be stainless steel.

JETS

The headers are equipped with straight through orifices and stainless steel spray deflectors, and are directly related to pump specifications.

OPERATION AND TREATMENTS

Load - The operator places the pallet in a vertical position onto the infeed extension. The guide rails are so designed that the pallet may be loaded and unloaded from the side. The pallet then moves at the pre-determined speed of 4 to 12 ft. per minute through the following treatments:

1. Wash - Wash solution at a temperature up to 150°F, as determined by the customer, is recirculated and sprayed onto all outside surfaces of the pallet.
2. Rinse - The house water supply, at house temperature and pressure, provides the rinse treatment. Consumption is 4.2 gallons per minute at 40 PSI.
3. Discharge and Unload - The operator removes the washed and rinsed pallet from the 4 ft. discharge extension of the conveyor.

MOTORS

3/60/208-230-460 volts, meeting NEMA standards. Other specifications available.

Motor shall be Wash Down Duty or Chemduty.

WIRING

The Girton Model CW10PS will include two position selector manual switches and contactors to separately control each pump. All systems come pre-wired. The stainless steel control box, shall include the following: control transformer, solid state overload relays, time delay fuses, emergency stop switch and illuminated status beacon with audible alarm.

In addition to the above, the following control system shall be included:

Allen Bradley MicroLogic 1200 Series PLC, and Microview operator interface.

PLC control – The heart of the control system will be an Allen Bradley Micrologix 1200 series PLC. The PLC shall be able to meet various voltage needs as well as I/O capabilities. As a standard, the input modules will be based on the 120 VAC-control voltage. The output modules will be isolated relays.

PLC control adds many features that standard relay logic cannot provide (or cannot provide without a large expense). These features include low level pump protection; low level heating protection; staggered start up of large motors; diagnostic ability of heating, pump overloads, and instruments, advanced conveyor control; as well as other features involving time delays and complex functions.

Equipment diagnostics and alarms help prevent down time by finding equipment failures quickly rather than waiting for operating personnel to recognize a failure.

The PLC software shall insure the highest level of safety for personnel, as well as the machinery, by providing alarms and control features that prevent potentially dangerous situations.

Operator interface – A Microview two line LCD data display shall be provided as an operator interface. This display shall be equipped with a keypad for input of critical parameters that the PLC controls. The display shall show status or alarm messages when required, informing the operator of any abnormal situations.

The washer will be wired and tested before leaving the factory.

A safety disconnect, provided by the customer, should be mounted on an adjacent wall, and customer will provide wiring from this switch to the washer's main control panel.

SERVICE REQUIREMENTS

3/60/230 volts, 1/60/115 volt controls, 60 amps.

1 - 1" water line, 40 PSI minimum pressure, 4.2 GPM operating consumption.

1 - 2" gravity drain connections.

2 - 10" ID vent connection, total 1420 CFM required.

OPTIONS

1. All stainless steel circulating pump.
2. Automatic conveyor stop switch, activated by the pallet (in case the operator is not present to remove it as it discharges from the washer), shuts off the drive motor.
3. Final rinse conservation switch. Consists of solenoid valve to control final rinse water from plant supply, thereby conserving fresh water when no pallets are moving through the washer.
4. Air blow-off section, to remove excess moisture from the surface of the pallets. A squirrel-cage type blower is used to distribute air through stainless steel plena onto all surfaces of the pallets. (Adds 5 ft. to the overall length of the washer. Also adds 15 amps at 230 volts and 10 amps at 460 volts.)
5. Gauge for ready recirculating pump pressure.
6. Additional infeed or discharge conveyor.
7. Steam injection heating of wash tank, steam piping shall be stainless steel, 40 PSI minimum 575 lb/hr consumption, for 180° F wash.
8. Steam coil for indirect heating of wash tank, 1" pipe size, 40 PSI minimum 575 lb/hr consumption for 180° F wash.
9. Pass through heat exchanger to raise house 120° F. water supply to 180° F. for final rinse.
10. Electric heat in lieu of steam heat 3/60/230 volt 108 KW for 150°F wash.
11. Electric heat in lieu of steam heat 3/60/480 volt 216 KW for 180°F wash.
12. Natural Gas Heat – 510,000 BTU/hr.
13. Pallet Dispenser – After the stack has been placed into the dispenser, the dispenser receives a signal to dispense a pallet, the chains start and a pallet is dispensed. When the pallet has been completely discharged, the pallet will be upended and placed on conveyor. The conveyor will turn on and convey the pallet into the pallet washer. When the pallet is completely in the washer, the dispenser will return to the down position and the lift table in the dispenser will travel up. The pallet support will retract and the lift table will start down. The pallet support will then come in to support the second pallet from bottom and rest of stack. The lift table will travel down, placing the next pallet on the chains to be dispensed.
14. Pallet Stacker– After the pallet has been washed, it is conveyed into the pallet lowering device. The pallet is then lowered onto the stacker chains and conveyed into the pallet stacker. The lift table will raise to the pallet supports. The supports come in to hold the pallet and the lift table lowers, ready to accept additional pallets.
15. Stainless Steel pallet contact surfaces for dispenser and stacker in lieu of painted steel.

GIRTON SERIES 5000 PALLET DISPENSER AND STACKING SYSTEM

SPECIFICATIONS

One (1) Girton Series 5000 Automatic Pallet Dispenser and Stacking System, which has a capacity for 15 pallets. The pallet is discharged in a straight through configuration on two strands of 50 pitch chain. The frame consists of 4" x 4" and 3" x 3" square tubing, 6" x 8.2 lb. channels and 3" I beams. Limit switches and solenoid valves are base mounted for easy maintenance. Expanded metal, lift out safety guards with hex head bolt retainers. Self contained hydraulic pumping unit with solenoid valves, flow control valves, relief valves and gauges.

SPEED: 2 pallets per minute (note speed is faster than washer to allow for proper machine cycling).

PALLETS: 48" x 32" x 7" wood pallets.

HYDRAULIC EQUIPMENT: Pump – Parker or Denison
Motor – Charlynn
Cylinder – Parker or Denison
Piping – Steel tubing with flex ends
Valves – Parker or Denison

ELECTRICAL EQUIPMENT: Motor – Baldor, TEFC
Starter – Allen Bradley or Square D
Push Buttons – Allen Bradley or Square D
Limit Switches – Microswitch or Allen Bradley
Photocells – Microswitch or Allen Bradley
Programmable Controller – Allen Bradley SLC 500 Family
Wiring – THHN 14 gauge in Seal Tite conduit

NEMA 12 enclosures with terminal hook up

PNEUMATIC EQUIPMENT:

Cylinders – Parker
Solenoid – Parker
Filter/Regulator – Watts
Piping – Flexible hose

PAINT:

Oil based polyurethane

UTILITIES:

3/60/230-460volt 5Hp ea.

AIR SUPPLY:

Minimum 2 CFM at 80 psig

OPTIONAL:

Stainless Steel pallet contact surface.

End of Specification

REV	DATE	BY	DESCRIPTION	EON
***	***	***	***	***

PASCO SERIES 5000 PALLET DISPENSER/STACKER SYSTEM SPECIFICATIONS

SPEED: ----- 2 PALLETS PER MINUTE
PALLETS: ----- 40 X 48 / 48 X 48 PLASTIC PALLETS / 36 X 72 X 6 WOODEN

ELECTRICAL EQUIPMENT: MOTOR- SAUDOR, TEFC
 STARTER- ALLEN BRADLEY
 PUSH BUTTONS- ALLEN BRADLEY
 LIMIT SWITCHES- ALLEN BRADLEY
 PHOTO ELECTRICS- ALLEN BRADLEY
 PROGRAMMABLE CONTROLLER- ALLEN BRADLEY, SLC 504
 WIRING- IRRM 14 GA. IN RUB ROY CONDUIT
 ENCLOSURE- HOFFMAN - NEMA 4X WITH TERMINAL HOOK UPS
 JUNCTION BOXES- HOFFMAN - NEMA 4X WITH TERMINAL HOOK UPS
 FIELD WIRING BY OTHERS

PNEUMATIC EQUIPMENT: CYLINDERS- PARKER
 SOLENOID VALVES- PARKER
 FILTER/REGULATOR- PARKER
 PIPING- FLEXIBLE HOSE

PAINT: ----- OIL-BASED POLYURETHANE ENAMEL ----- (PLEASE CHOOSE COLOR) -----

UTILITIES: ----- 480 VOLT, 3 PHASE, 60 HERTZ, 5 H.P., 20 AMPS. (PLEASE VERIFY)

AIR SUPPLY: ----- MINIMUM 2 CFM AT 80 PSIG

STAINLESS STEEL PACKAGE: ----- PALLET CONTACT SURFACES

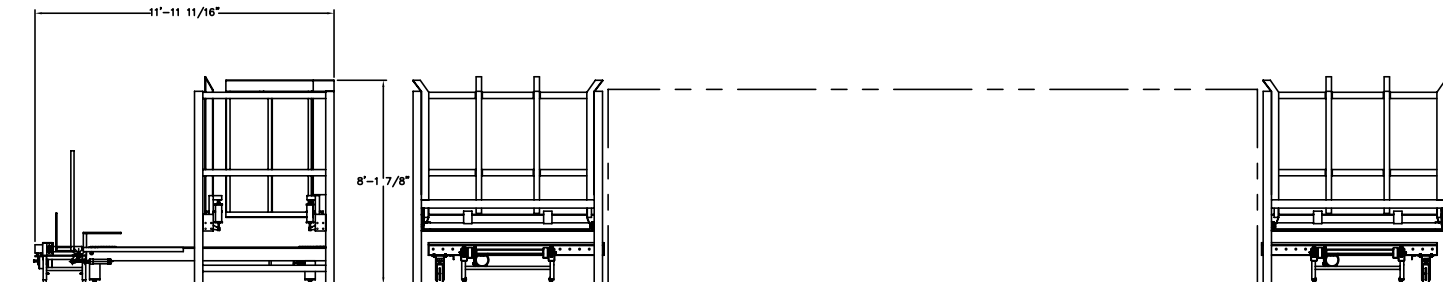
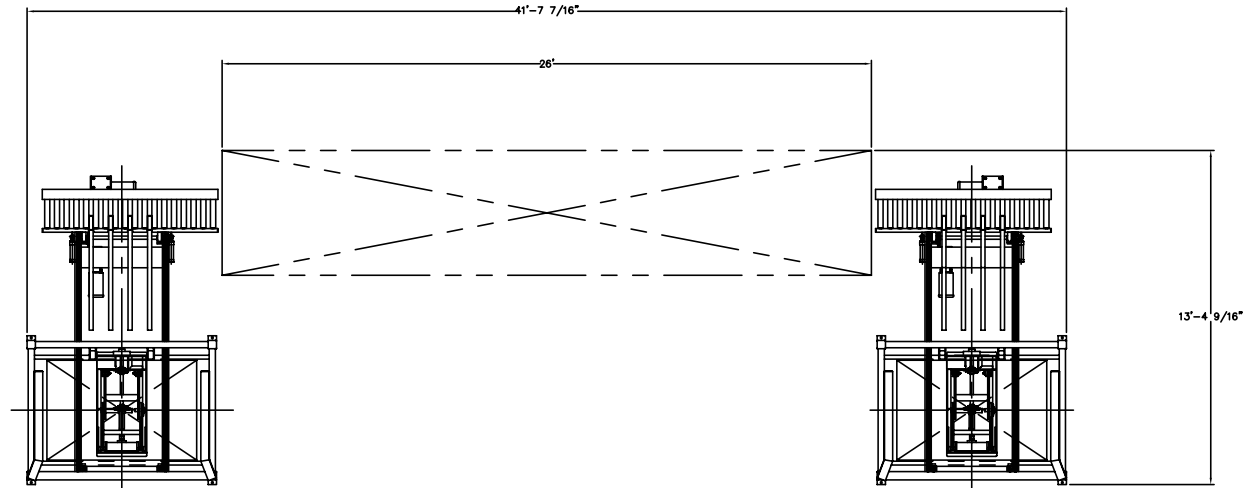
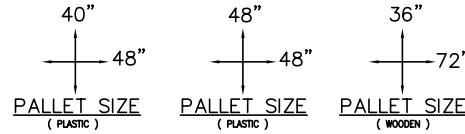

TOLERANCES		PASCO	
TOLERANCES UNLESS SPECIFIED OTHERWISE		2850 SOUTH HANLEY ROAD, SUITE 400, ST. LOUIS, MO. 63144 (314) 761-2212 FAX (314) 761-9888	
FRACTIONS 1/16		PALLET DISPENSER/PALLET STACKER	
HOLE 0.015		APPROVAL DRAWING	
HOLE 0.005		JOB #1306 (TROPICANA)	
ANGLES 0.1°		DRAWN BY: AID	
BREAK SHARP EDGES 0.3		DATE: 10/26/97	
FILES 0.015 R MAX		DRAWING NUMBER: 1306AP	
SURFACE FINISH 250 / MAX		DATE: _____	
INTERNAL		SCALE: 3/8"=1"	
DATE BY: _____		SHEET: 1 OF 1	
APPROVED BY: _____		REV: 0	