

## Installation, Start-Up and Service Instructions

### SAFETY CONSIDERATIONS

The 50BT, BU Units are designed to provide safe and reliable service when operated within design specifications. However, due to system pressures, electrical components, and equipment location, some aspects of installation, start-up, and servicing of this equipment can be hazardous.

Only trained, qualified installers and service mechanics should install, start up, and service this equipment.

When working on the equipment, observe all precautions on tags or labels attached to the unit, safety notes in the literature, and any other safety precautions that apply.

- Follow all safety codes.
- Wear safety glasses and work gloves.
- Use care in handling, rigging, and placing bulky equipment.

#### ⚠ DANGER

Never reach into unit while fan is running.  
Lock open and tag fan motor power disconnect before working on a fan. Remove the fuses and take them with you after noting this on tag.

#### ⚠ WARNING

Check assembly and component weights to be sure rigging equipment can handle them safely. Note also any specific rigging instructions.  
When steam cleaning coils, be sure area is clear of personnel.

### GENERAL

The units are self-contained units arranged for vertical air discharge and are wired and piped at the factory.

The 50BT units are water-cooled units with factory-supplied condensers. The 50BU units are condenserless, and are to be used with field-supplied remote air-cooled condensers.

Applicable installation codes may limit this cabinet to installation only in a single-story residence.

### INSTALLATION

**Step 1 — Inspect Unit** — Check unit against shipping order. Inspect carefully for concealed shipping damage. *If shipment is damaged or incomplete, file claim with transportation company and advise Carrier immediately.*

### CONTENTS

	Page
<b>SAFETY CONSIDERATIONS</b> .....	1
<b>GENERAL</b> .....	1
<b>INSTALLATION</b> .....	1-9
<b>Step 1 — Inspect Unit</b> .....	1
<b>Step 2 — Protect Unit from Damage</b> .....	1
<b>Step 3 — Provide Unit Support</b> .....	1
<b>Step 4 — Install Accessory Heating Coil</b> <b>(If Applicable)</b> .....	2
<b>Step 5 — Rig and Place Unit</b> .....	2
<b>Step 6 — Install Accessory Plenum</b> <b>(If Supplied)</b> .....	2
<b>Step 7 — Align Fan Shaft and Wheel</b> .....	2
<b>Step 8 — Install Ventilation-Air (Evaporator)</b> <b>Ductwork</b> .....	2
<b>Step 9 — Install Return-Air Ductwork</b> <b>(If Required)</b> .....	5
<b>Step 10 — Check Return-Air Filters</b> .....	5
<b>Step 11 — Check Compressor Spring Mounts</b> <b>(50BT, BU008 and 012)</b> .....	5
<b>Step 12 — Make Condenser Connections</b> .....	6
<b>Step 13 — Charging the System</b> .....	7
<b>Step 14 — Install Unit Drain Line</b> .....	7
<b>Step 15 — Make Electrical Connections</b> .....	7
<b>START-UP</b> .....	10
Unit Size 50BT, BU004 and 006 .....	10
Unit Size 50BT, BU008 and 012 .....	10
To Shut Down Unit .....	10
Service Valves .....	10
<b>SERVICE</b> .....	11-14
Indoor-Air Fan Adjustment .....	11
Lubrication .....	11
Return-Air Filters .....	11
Condensate Drains .....	11
Evaporator Coil .....	11
Water-Cooled Condensers .....	12
Air-Cooled Condensers .....	12
Charging the System .....	12
Return-Air Grille Removal .....	13
Access Panel Removal .....	13
Indoor-Air Fan Motor Removal .....	13
Pressure Relief Device .....	14
Crankcase Heater .....	14
Cycle-LOC™ Protection Device .....	14
Time Guard® II Control .....	14
High and Low Pressurestats .....	14
Oil Charge .....	14

**Step 2 — Protect Unit from Damage** — To maintain warranty, protect unit against adverse weather, theft, or vandalism on jobsite.

**Step 3 — Provide Unit Support** — Refer to Fig. 1 and Table 1 for unit size and weight.

If desired, construct a stand or frame of I-beams or angle iron that adequately supports unit. The floor and floor joists of existing buildings may require reinforcement; follow applicable codes.

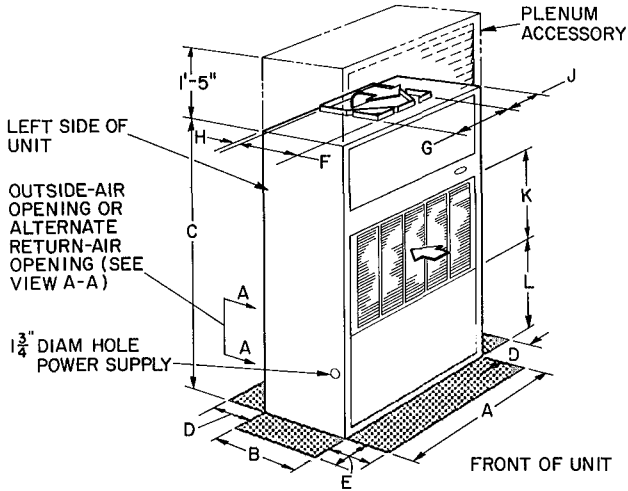

UNIT 50BT, BU	004	006	008, 012
A	3-0 <sup>9</sup> / <sub>16</sub>		4-0
B	1-9		2-5
C	5-3 <sup>7</sup> / <sub>8</sub>		6-5
D	See Note 2		1-0
E			2-0
F	1-1 <sup>13</sup> / <sub>16</sub>	1-4 <sup>7</sup> / <sub>16</sub>	1- 7 <sup>7</sup> / <sub>8</sub>
G	1-1 <sup>1</sup> / <sub>8</sub>	1-3	1- 5 <sup>1</sup> / <sub>4</sub>
H	—	0 <sup>3</sup> / <sub>4</sub>	0- 1 <sup>1</sup> / <sub>4</sub>
J	1-0 <sup>1</sup> / <sub>2</sub>	0-10 <sup>3</sup> / <sub>8</sub>	0-11 <sup>7</sup> / <sub>8</sub>
K	1-9 <sup>1</sup> / <sub>8</sub>		2-1 <sup>3</sup> / <sub>4</sub>
L	1-9 <sup>1</sup> / <sub>4</sub>		2-1 <sup>5</sup> / <sub>8</sub>
M	2-7 <sup>7</sup> / <sub>8</sub>		3-6
N	0- 2		0-3
P	0-10		1-0 <sup>1</sup> / <sub>2</sub>
Q	1-3 <sup>9</sup> / <sub>16</sub>		1-4

NOTES:

1. Certified dimension drawings available upon request.
2. Minimum required clearance at back and right side of unit is zero. Clearance above and at left of unit depends on space required for accessory plenum, ductwork, condenser piping, accessory heater piping, condensate drain line, and power wiring. Clearance required at front of unit for service access and free return airflow is 2 ft. Clearance in front of unit is to facilitate service of compressor and condenser (50BT units).
3. Water and refrigerant connections are located on the left side of unit. See Step 12, Make Condenser Connections, for connection details.

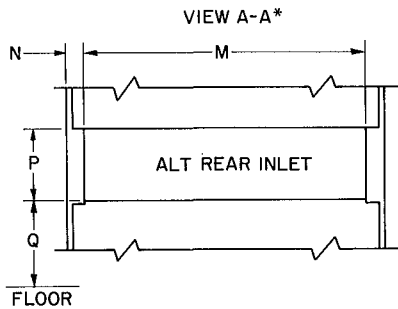

\*ALTERNATE RETURN-AIR OPENING OR OUTDOOR AIR OPENING

Fig. 1 – Unit Dimensions

**Step 4 – Install Accessory Heating Coil (If Applicable)**

50BT, BU004 AND 006 UNITS — Any water or steam heating coil must be installed through the back of the unit as described in the Installation Instructions shipped with the accessory coil.

**Step 5 – Rig and Place Unit**

NOTE: Install accessories before placing unit. Provide space around unit for service, filter access, and overhead clearance as indicated in Fig. 1.

Move and store unit in upright position.

50BT, BU004 AND 006 — Use rollers under shipping rails. Unit may be moved by hand truck on any side. Do not remove shipping rails until unit is in final position.

50BT008 AND 012 — Use slings with spacer under base skid to prevent panel damage when using hoist.

ALL UNITS — Units as shipped are adequately dampened against vibration. If additional dampening is desired, place sponge rubber, rubber mat, or fiberglass roof insulation between floor and base of unit or install vibration isolators.

Unit should be level. Unit leveling tolerance is 1/8 in. per linear ft in any direction.

**Step 6 – Install Accessory Plenum (If Supplied)** — On unit sizes 004 and 006, holes in the unit top panel match holes in plenum. Use screws provided to attach plenum to top panel. See Fig. 1 and 2.

On unit sizes 008 and 012, use plenum as template to mark hole locations in top panel. Drill .150-in. (size 008)

or .154-in. (size 012) holes in top panel at marked locations and attach plenum with screws supplied.

**Step 7 – Align Fan Shaft and Wheel**

HORIZONTAL WHEEL CENTERING — All wheels must be horizontally centered between the inside edges of their fan scroll venturis (Fig. 3).

Adjust as follows:

1. Loosen setscrews holding wheel to shaft (Fig. 4).
2. Center the wheel by sliding it horizontally.
3. Retighten setscrews.

CONCENTRIC ALIGNMENT — Shaft and wheels must be concentrically centered with the venturi or air inlet of the fan housing (Fig. 5).

Shaft bearings are supported by bearing supports (Fig. 6). If shaft and wheels are concentrically misaligned from shipping shock, it is possible to re-bend bearing support arms to original positions. Replace the bearing support if it has been extensively damaged during shipping.

**Step 8 – Install Ventilation-Air Ductwork —**

Connect ventilation ducts to flanges on outside-air supply opening (Fig. 1) using a flexible connection. Attach ductwork to building structure and insulate with fiberglass and vapor barrier to reduce sound transmission and prevent vapor condensation.

Weatherproof external ductwork, joints, and openings with flashing and mastic in accordance with applicable codes.

Ducts passing through an unconditioned space must be insulated and covered with a vapor barrier.

**Table 1 – Physical Data**

BASE UNIT 50	BT	BU	BT	BU	BT	BU	BT	BU
	004		006		008		012	
<b>NOMINAL CAPACITY (tons)</b>	3		5		7½		10	
<b>OPERATING WEIGHT (lb)</b>	390		427		895		950	
Base Unit	25	330	25	360	50	835	50	890
Discharge Plenum								
<b>COMPRESSOR – TYPE 06</b>	Welded Hermetic				Scroll			
RPM	3500				Serviceable Semi-Hermetic			
Model No.	CRG3	CRH3	CRM3	ZR61	06DA818	06DB724	06DB824	
Qty Cylinders	2	2	2	N/A*	4	4	6	6
Qty Unloading Cylinders	0		0		0		2	
Qty Capacity Steps	1		1		1		2	
High-Pressure Switch								
Opens	395 ± 10	No HP Sw	395 ± 10	426 ± 7	395 ± 10	426 ± 7	395 ± 10	426 ± 7
Closes	295 ± 20		295 ± 20	295 ± 20	295 ± 20	295 ± 20	295 ± 20	295 ± 20
Low-Pressure Switch								
Opens	No LP Sw	No LP Sw	27 ± 4	27 ± 4	27 ± 4	27 ± 4	27 ± 4	27 ± 4
Closes			67 ± 7	67 ± 7	67 ± 7	67 ± 7	67 ± 7	67 ± 7
<b>OPERATING CHARGE (lb)</b> (Holding Charge)	3.1	(0.6)	5.3	(0.6)	R-22		10	(1.0)
<b>CONDENSER (BT Only)</b>								
No. ...Type					1 ... TT			
Water Volume – Gal.	0.39	–	0.86	–	2.42	–	2.42	–
<b>INDOOR-AIR FAN</b>	Adjustable, Belt-Driven				Centrifugal; 1725 Rpm Motor			
Nominal Cfm	1200		2000		3000		4000	
Standard Speed Range (rpm)	512-782		647-915		495-700		600-850	
Max Allowable (rpm)					1050			
Belt Qty...Pulley PD (in.)	1...6.4				1...8.5		1. 7.0	
Motor Pulley PDR (in.)	1.9-2.9				2.4-3.4			
<b>Nominal Horsepower Frame Size</b>	<b>Std</b>	⅓ 48	¾ 56		1 ..56	2. 145T	1½ ..56Y (208/230, 460 v) 2 ..145T (other models)	
	<b>Alt</b>	¾ 56	1 .56		2. 145T or	3...182T	2...145T (208/230, 460 v)	
	<b>Alt</b>	–	–		3...182T	–	3...182T	
<b>INDOOR COIL</b>	⅜-in. OD, Copper Tubes, Aluminum Fins							
<b>Tube Type</b>	Prime				Prime			
<b>Qty Rows...Fins/in.</b>	2 ..14.4		3 . 14.4		7.3		3. .12.5	
<b>Face Area (sq ft)</b>	5.0						8.5	
<b>RETURN-AIR FILTERS</b>	Factory Supplied, Disposable							
<b>Qty...Size (in.)</b>	2.. 16 x 25 x 1				4 ..16 x 20 x 1			
<b>CONDENSER CONN (BT Only)</b>	Size (in) . .Type							
<b>Water Inlet (Bottom)</b>	½...FPT		¾...FPT		1 ..FPT		1 ..FPT	
<b>Water Outlet (Top)</b>	½...FPT		¾...FPT		400			
<b>Max Working Pressure (psig)</b>								
<b>REFRIGERANT CONNECTIONS (BU Only)</b>								
<b>Hot Gas Line</b>	½ .FI				¾...ODF			
<b>Liquid Line</b>	½...FI				⅝ .ODF			
<b>CONDENSATE CONNECTION DRAIN</b>	¾...FPT							
<b>ACCESSORY HEATING COIL</b>								
<b>Hot Water</b>								
<b>Rows...Fins/in.</b>	1.. 15		2...14		6.0			
<b>Face Area (sq ft)</b>	5.0							
<b>Steam</b>								
<b>Rows...Fins/in.</b>	1...15		1...14		6.9			
<b>Face Area (sq ft)</b>	5.0							
<b>HEATING COILS CONNECTIONS</b>	No. ...Size (in. MPT)							
<b>Hot Water</b>								
<b>Inlet</b>	1...⅞		1 ..1¼		1 ..1¼			
<b>Outlet</b>	1.. ⅞		1 ..1¼		1 ..1¼			
<b>Steam</b>								
<b>Inlet</b>	1. ⅞		1 .1¼		1 .1¼			
<b>Outlet</b>	1...⅞		1 ..1¼		1 ..1¼			

**LEGEND**

- |                                      |                                   |
|--------------------------------------|-----------------------------------|
| <b>FI</b> – Flare                    | <b>PD</b> – Pitch Diameter        |
| <b>HP</b> – High Pressure            | <b>PDR</b> – Pitch Diameter Range |
| <b>LP</b> – Low Pressure             | <b>SW</b> – Switch                |
| <b>ODF</b> – Outside Diameter Female | <b>TT</b> – Tube in Tube          |

\*Not applicable.

†Internally grooved

**NOTES:**

- All 50BU units are shipped with a holding charge. Operating charge includes charge for remote air-cooled condenser or connecting pipe.
- Motors and drives other than those furnished with unit must be purchased locally. Installation may require field modification. Contact your local Carrier representative. Refer to Table 2
- Accessory heating coil in 004 and 006 units is combination hot water/steam

Table 2 – Fan Motors and Drives

UNIT 50	FAN MOTOR (STANDARD)			FAN MOTOR (ALTERNATE)		FAN		CENTER LINE DISTANCE (in.)		FAN SHAFT DIAM. (in.)	
	Hp	NEMA Frame Size	Rpm	PDR (in.)	Hp	NEMA Frame Size*	PPD (in.)	FSR (Rpm)	Max.		Min.
BT,BU004	1/3	48†	1725	1.9-2.9	3/4	56	6.4	512-782	17.5	15.7	1/2
BT,BU006	3/4	56		2.4-3.4	1	56		647-915	17.1	15.4	5/8
BT,BU008	1	56		2.4-3.4	2	145T	8.5	495-700	10.2	6.8	3/4
					3	182T					
BT012	2	145T or 56**			3	182T	7.0	600-850			
	2††	145T or 56**			3	182T					
BU012	1-1/2‡	56Y	2.4-3.4	2	145T (208/230, 460 v)						
				3	182T (460 v)						

LEGEND

- FSR — Fan Speed Range (Rpm)
- NEMA — National Electrical Manufacturing Association
- PDR — Pitch Diameter Range (in ) of adjustable motor pulley
- PPD — Pulley Pitch Diameter (in.)

- \*Range of motor sizes unit will accept.
- †Motor mounting brackets are not interchangeable. When replacing 48 frame motor with 56 frame motor, use 56 frame motor mounting bracket. Alternate fan motors and drives are field supplied.
- \*\*Special 56 motor frame interchangeable with 145T.
- ††575-v units
- ‡208/230-v and 460-v units.

NOTE: Motors and drives other than those furnished with unit must be purchased locally.

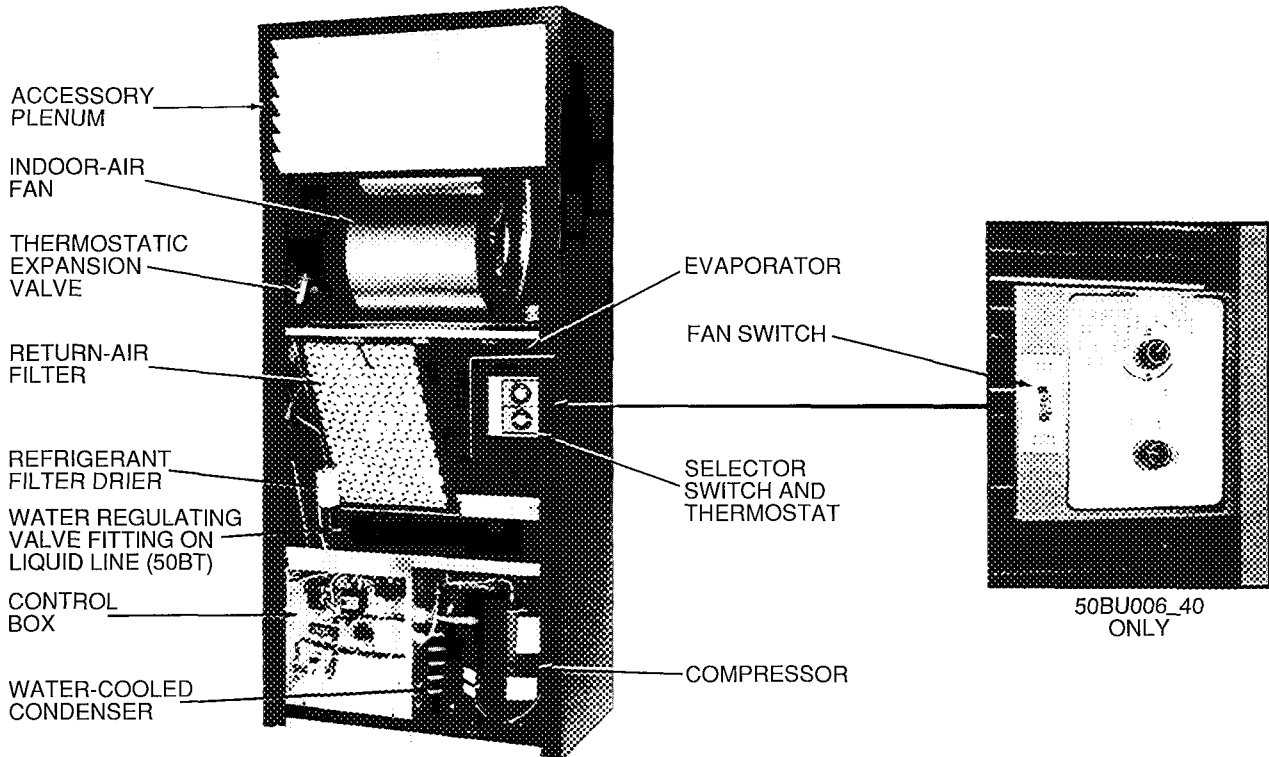
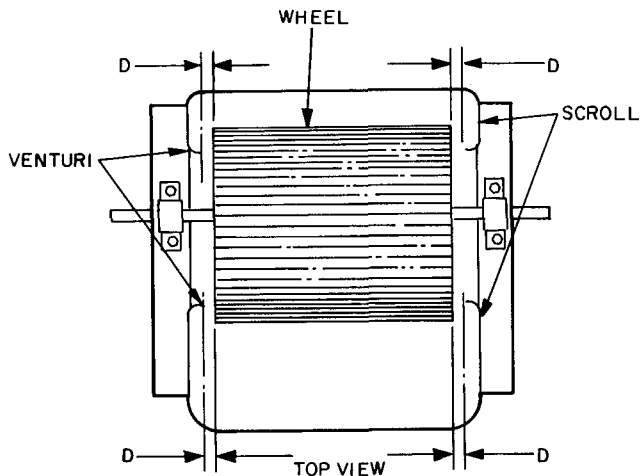
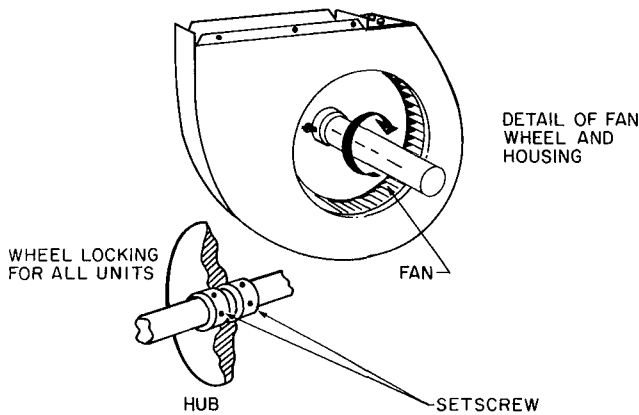

Fig. 2 – Base Unit Interior Details (Typical 50BT Unit Shown)



DIMENSION "D"  
MUST BE EQUAL ALL AROUND

**Fig. 3 – Horizontal Wheel Centering**



**Fig. 4 – Fan Locking Detail**

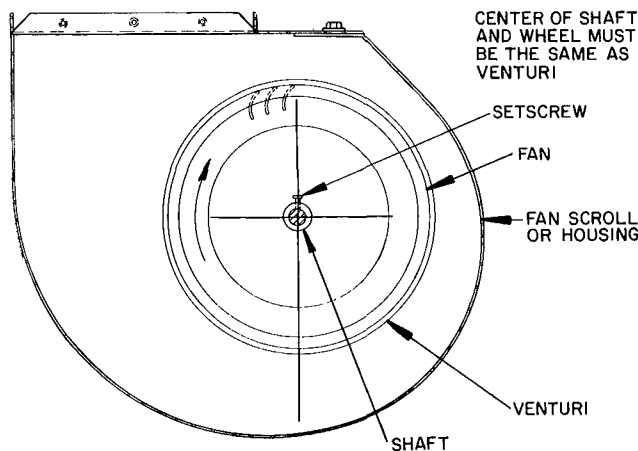

**Fig. 5 – Concentric Alignment**

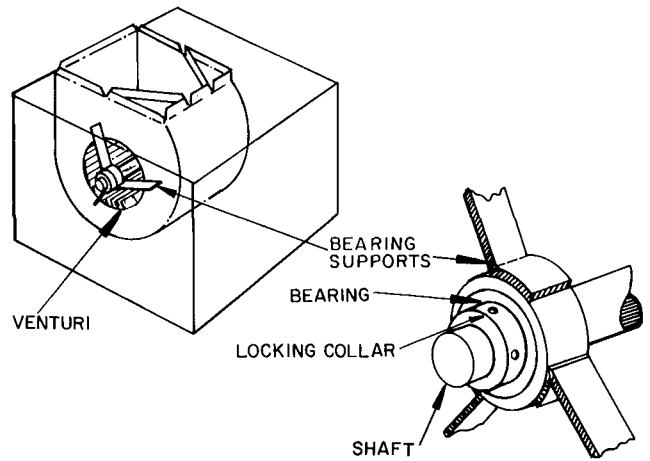

**Fig. 6 – Fan Shaft Bearings**

**Step 9 – Install Return-Air Ductwork (If Required)** – The unit back panel is stamped to indicate alternate return-air (or outdoor-air inlet) opening as indicated in Fig. 1.

1. Cut out the alternate return-air opening as required.
2. Attach a one-in. flange to unit back panel or attach a flanged, flexible duct connection directly to unit as desired.

If an outdoor makeup air damper is to be installed, attach it directly to unit back panel and install flexible connection between damper assembly and remaining ductwork.

Use accepted ductwork installation procedures. Follow all applicable codes.

3. Restrict or completely blank off the standard return-air opening with a field-fabricated filler panel. This panel must be removable for service access. Refer to Service, Return-Air Grille Removal, as required.

**Step 10 – Check Return-Air Filters** – Be sure filters shipped with unit are the correct size (see Table 1). *Never operate unit without return-air filters in place.*

**Step 11 – Check Compressor Spring Mounts (50BT, BU008 and 012)** – The compressors are held rigid in shipment by bolts extending through a washer, grommet, and compressor foot into a weld nut.

Loosen each bolt (4 per compressor) until compressor floats freely on springs. Then retighten bolts until there is slight pressure on the neoprene gasket. This will steady the compressor and prevent start and stop rocking.

The compressors have reversible oil pumps that operate in either direction; therefore, the direction of rotation need not be checked.

NOTE: Since the compressors on the 50BT/BU004,006 are internally isolated, do not loosen compressor mounting nuts.

## Step 12 – Make Condenser Connections

**WATER-COOLED (50BT) UNITS** — Condensers have water inlet and outlet connections as shown in Fig. 7. Piping arrangements for city, waste, or recirculating water are shown in Fig. 8.

Connect condenser water supply and return lines as indicated in Fig. 7 and 8. When connecting water lines, hold the condenser inlet and outlet stubs firmly with a wrench at the female pipe thread (FPT) hex fitting to prevent twisting. Do not use water lines smaller than connection sizes shown in Fig. 8. Observe all applicable plumbing and sanitary codes.

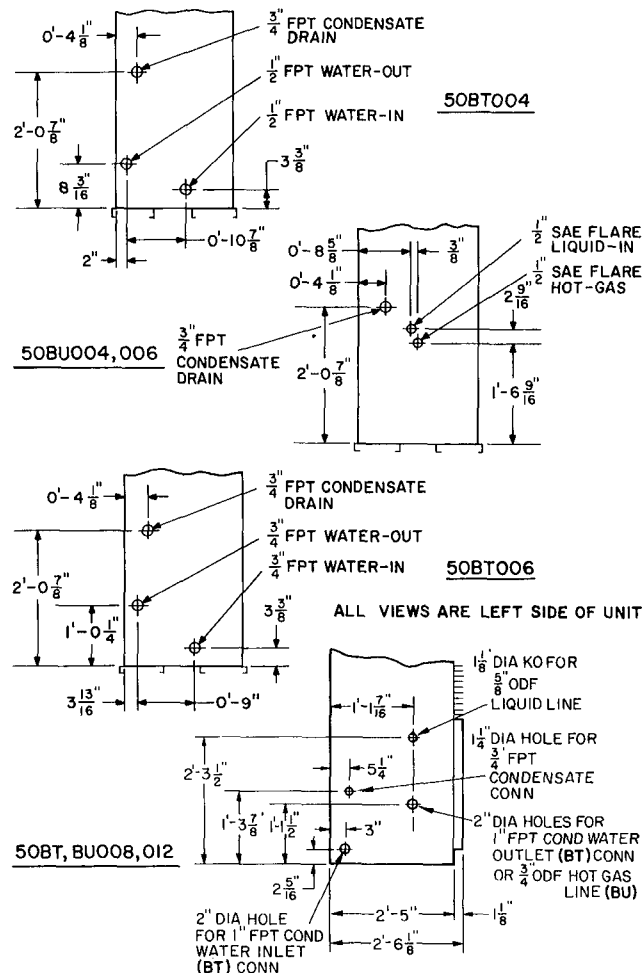

SAE — Society of Automotive Engineers

**Fig. 7 — Water and Refrigerant Connections**

**Table 3 — Recommended Line Sizes (in.) (50BU Condenserless Models)**

UNIT 50BU	CKT	COOLING UNIT CONN SIZES		LENGTH OF RUN (ft)							
				0-25		26-50		51-75		76-100	
		HG	Liq	HG	Liq	HG	Liq	HG	Liq	HG	Liq
004 SAE Flare	1	1/2	1/2	1/2	1/2	5/8	1/2	5/8	1/2	7/8	1/2
006 SAE Flare	1	1/2	1/2	5/8	1/2	7/8	1/2	7/8	1/2	7/8	1/2
008 ODF	1	3/4	5/8	7/8	5/8	7/8	5/8	7/8	5/8	1-1/8	5/8
012 ODF	1	3/4	5/8	7/8	5/8	1-1/8	5/8	1-1/8	5/8	1-1/8	5/8

**LEGEND**

HG — Hot Gas  
ODF — Outside Diameter Female  
SAE — Society of Automotive Engineers

50BT004	1/2-in. FPT Conn.
50BT006	3/4-in. FPT Conn.
50BT008,012	1-in. FPT Conn.

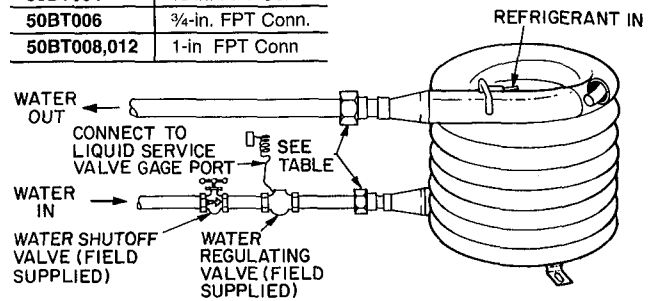

**Fig. 8 — Typical Condenser Water Piping (50BT004 Unit Shown)**

If specified, install field-supplied water-regulating valve in water supply line outside cabinet as follows:

1. Route the regulating valve capillary with its flare nut to the fitting on refrigerant liquid line (Fig. 2), using any convenient unused opening on side of unit. Use a grommet in unit panel to prevent chafing of capillary.
2. Remove cap from liquid line fitting.
3. Remove cotter pin taped to liquid line near fitting. Insert pin, split end first, into water regulating valve flare nut.
4. Connect flare nut to fitting. Round end of cotter pin will depress core of fitting. The opened fitting allows refrigerant pressure to act on water regulating valve. Tighten flare nut to prevent leakage.

The fitting automatically seals (closes) when flare nut is removed, and a slight amount of refrigerant is lost. Do not lose cotter pin.

**AIR-COOLED (50BU) UNITS** — Install air-cooled condenser in accordance with the installation instructions provided with condenser. Connection locations for liquid and hot gas service lines are shown in Fig. 7. Recommended line sizes are given in Table 3. Refer to Carrier System Design Manual, Part 3, for standard refrigerant piping techniques.

Condenserless (50BU) units are shipped with a holding charge. After refrigerant connections are made, reclaim refrigerant, evacuate, leak test, and charge system as described in Service, Charging the System.

### Step 13 – Charging the System

UNIT SIZES 50BU004 AND 006 — These units, used with remote air-cooled condensers, are shipped with a holding charge only. To charge:

1. Open hot gas and liquid line service valves.
2. Reclaim holding charge, evacuate and leak-test system.  
*On Unit 50BU006\_40 Only* — Refrigerant *must* be removed from both the HIGH and LOW side to fully evacuate refrigerant system of all refrigerant.
3. Using standard refrigerant charging techniques and charging charts (page 13), add refrigerant as required to maintain proper operating conditions. See Table 4 for additional charge needed for piping runs over 15 ft.

**IMPORTANT:** For 50BU006\_40 Units — Charge compressor on both the HIGH and LOW side simultaneously, to prevent axial loading of the scroll, which may cause a temporary *no start* condition for the compressor. If this occurs, let the system set for approximately 30 minutes. Attempt to restart the compressor; internal pressures should equalize enough to allow compressor to start.  
If removing the compressor, evacuate both the HIGH and LOW side simultaneously.

**Table 4 – Additional Charge (lb) For Interconnecting Piping and Components (16 – 100 Ft)\***

SYSTEM INDEX		UNIT SIZE – 50BU			
Length (ft)	Ckt	004	006	008	012
16 – 25	1	0.77	0.80	1.31	1.31
26 – 50	1	2.78	3.08	4.59	4.97
51 – 75	1	4.77	5.28	7.86	8.52
76 – 100	1	7.48	7.48	12.08	12.08

\*Additional charge necessary for units with piping runs in excess of 15 ft.

NOTE: All charges are approximate (lb), for estimating purposes only

UNIT SIZE 50BU008 AND 012 — These units, used with remote air-cooled condensers, are shipped with a holding charge only. To charge:

1. Open suction and discharge line service valves.
2. Reclaim holding charge, evacuate and leak-test system.
3. Add sufficient refrigerant vapor to permit continuous operation after starting unit.
4. Start unit per Start-Up section; then, using standard charging techniques, add refrigerant as required to maintain normal operating conditions.

Use charging chart supplied with condenser, if available. If information is not available, block off enough of condenser coil to maintain 220 psig discharge pressure and charge to a clear sight glass.

**Step 14 – Install Unit Drain Line** — Install a trapped condensate drain line at unit drain connection (Fig. 7). The drain requires standard pipe connected to condensate pan nipple. Figure 9 shows proper trap design.

Determine design negative static pressure. This pressure is not the same as fan total pressure, which includes pressure losses downstream as well as upstream from the indoor-air fan. Always assume the worst conditions, such as having return-air filters clogged with dirt.

Referring to Fig. 9, Differential 1 must be equal to or larger than negative static pressure at design operating conditions. Store enough water in trap to prevent losing seal (Differential 2). Differential 2 must be equal to or larger than one-half the maximum negative static pressure. When the fan starts, Differential 3 is equal to the maximum negative static pressure.

Do not use drain line smaller than 3/4-inch. Use knockout hole provided in panel for drain line. Pitch drain downward toward an open drain sump. Provide a trap at least 3 in. high. Installation of a plugged tee is recommended for cleaning. Fill trap with water to make an air seal. Observe all sanitary codes.

### Step 15 – Make Electrical Connections

**GENERAL** — Provide an adequate fused disconnect switch per National Electrical Code (NEC) within sight from the unit. Provision for locking switch open (OFF) is advisable to prevent power from being turned on when unit is being serviced.

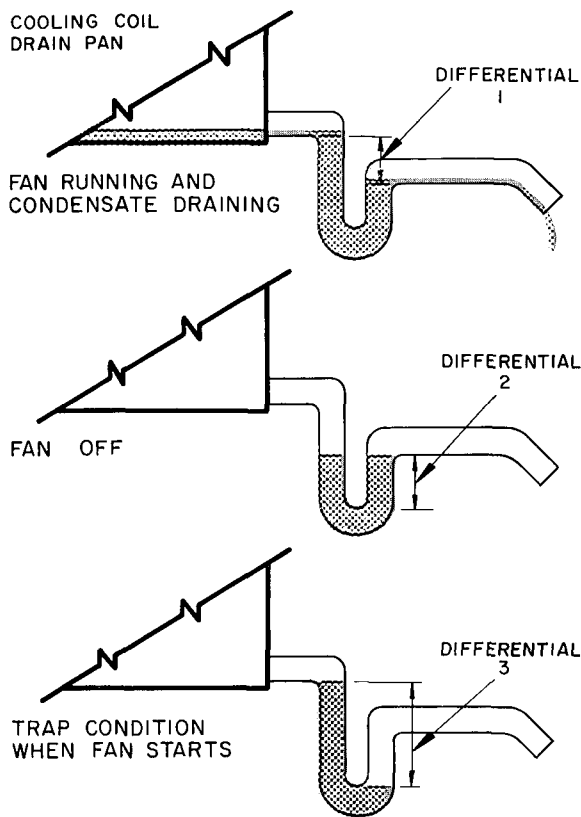

**Fig. 9 – Condensate Drain**

**POWER WIRING** — Conduit opening for all units is on left side of unit near control box.

Splice field power wires to factory wires at the compressor contactor.

Supply voltage must be in accordance with nameplate voltage. On 3-phase units, voltage between phases must be balanced within 2% and current within 10% with compressor running. Contact your local power company for correction of improper voltage or phase imbalance (see Table 5). Failure of unit because of phase imbalance constitutes abuse and can void the Carrier warranty.

**CONTROL WIRING** — On extended voltage (208/230-v) units, sizes 50BT, BU004-012, the control transformer is factory wired for 208-v usage. If unit is to be used on 230-v system, reconnect primary wiring on transformer as shown on unit wiring diagram.

Refer to Fig. 10 for field control wiring to condenser fan relay (50BU units).

On all units, the thermostat is factory installed. A sensing element in the return air is provided on the 50BT, BU008 and 012 units. To wire these units to a remote thermostat, or to a remote control switch and thermostat, refer to unit Wiring Diagrams book or contact your Carrier representative.

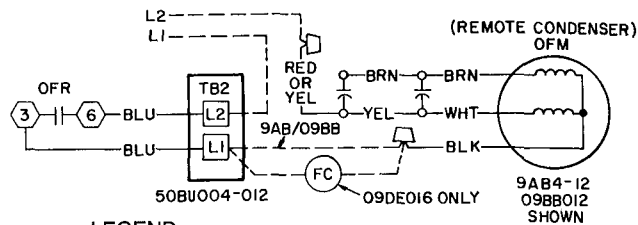

**LEGEND**

- FC** — Fan Contactor
- OFM** — Outdoor Fan Motor
- OFR** — Outdoor Fan Relay
- TB** — Terminal Block

**NOTE:** Outdoor (condenser) Fan Relay (OFR) is rated for ½ hp at 120/230 v.

**Fig. 10 – Field Control Wiring Connections**

**FREEZE-PROTECTION THERMOSTAT** — An accessory freeze-protection thermostat is required on size 006, 008, and 012 units when a liquid line loss-of-charge switch is installed for intermediate or cold-weather operation. Installation instructions are shipped with the thermostat.

**HEATING COILS** — Accessory heating coils are available for field installation. Separate installation instructions are shipped with the accessory.

**WINTER START MODIFICATIONS** — When starting 50BU air-cooled units (except 50BU004) under low-ambient temperature conditions, the compressor may pull suction pressure down below low-pressure switch cutout setting causing the compressor to shut off. At extremely low ambient temperatures, the low-pressure switch may be open during the off cycle, preventing the compressor from starting. In these cases, winter start control is required as follows:

<b>UNIT 50BU004</b>	Units do not have low-pressure switch. Evaporator freeze-up thermostat, Carrier Part No. 50BB900001, must be field installed.
<b>UNIT 50BU006</b>	Remove original low-pressure switch from suction line and disconnect. Install 5-psig low-pressure switch (HK02ZB005) on liquid line service valve connection. Field installation of evaporator freeze-up thermostat is also required.
<b>UNIT 50BU008, 50BU012</b>	Move low-pressure switch to liquid line service valve connection. Connecting low-pressure switch to liquid line maintains loss-of-charge protection but leaves system without freeze-up protection. Therefore, evaporator freeze-up thermostat (Carrier Part No. 50BB900001) must be added.

**UNBALANCED 3-PHASE SUPPLY VOLTAGE**

Use the following formula to determine the percent of voltage imbalance.

Percent Voltage Imbalance

$$= 100 \times \frac{\text{max voltage deviation from average voltage}}{\text{average voltage}}$$

Example: Supply voltage is 460-3-60.

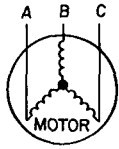

AB = 452 v  
BC = 464 v  
AC = 455 v

$$\begin{aligned} \text{Average Voltage} &= \frac{452 + 464 + 455}{3} \\ &= \frac{1371}{3} = 457 \end{aligned}$$

Determine maximum deviation from average voltage:

(AB) 457 - 452 = 5 v

(BC) 464 - 457 = 7 v

(AC) 457 - 455 = 2 v

Maximum deviation is 7 volts.

Determine percent of voltage imbalance:

$$\text{Percent Voltage Imbalance} = 100 \times \frac{7}{457} = 1.53\%$$

This amount of phase imbalance is satisfactory as it is below the maximum allowable 2 percent.

**IMPORTANT:** If the supply voltage phase imbalance is more than 2%, contact your local electric utility company immediately.

Unit failure as a result of operation on improper line voltage or excessive phase imbalance constitutes abuse and may cause damage to electrical components. Such operation would invalidate any applicable Carrier warranty.

**Table 5 – Electrical Data**

UNIT 50-	V-PH-HZ	VOLTAGE RANGE		COMPRESSOR				INDOOR FAN MOTOR		POWER SUPPLY			
				RLA		LRA				Min Ckt Amps*		MOCP Amps*	
		Min	Max	BT	BU	BT	BU	Hp	FLA	BT	BU	BT	BU
BT,BU004	230-1-60	207	253	15.5	—	75.8	—	1/3	3.3	22.7	—	35	—
	208/230-3-60	187	253	10.8	11.22	65.0	66.0	1/3	3.3†	16.8	17.3	25	25
	460-3-60	414	506	5.0	5.20	32.0	35.0	1/3	0.8	7.1	7.3	15	15
BT,BU006	230-1-60	207	253	27.5	32.10	125.0	169.0	3/4	5.3	39.7	45.4	60**	70**
	208/230-3-60	187	253	16.1	19.30	90.0	123.0	3/4	7.1†	27.3	31.2	40	50
	460-3-60	414	506	7.7	10.00	45.0	62.0	3/4	1.6	11.3	14.1	15	20
	575-3-60	518	632	6.4	7.10	27.0	52.0	3/4	1.1	9.1	10.0	15	15
BT,BU008	208/230-3-60	187	253	31.3	31.30	137.0	137.0	1	4.0	43.1	43.1	70**	70**
	460-3-60	414	506	14.1	14.10	62.0	62.0	1	1.6	19.2	19.2	30	30
	575-3-60	518	632	11.3	11.30	50.0	50.0	1	1.4	15.2	15.2	25	25
BT012	208/230-3-60	187	253	36.3	—	137.0	—	2	6.0	52.0	—	80**	—
	460-3-60	414	506	14.6	—	62.0	—	2	2.8	21.7	—	35	—
	575-3-60	518	632	11.4	—	50.0	—	2	2.3	16.6	—	25	—
BU012	208/230-3-60	187	253	—	39.70	—	198.0	1 1/2	6.0	—	55.6	—	90**
	460-3-60	414	506	—	19.10	—	99.0	1 1/2	2.9	—	27.8	—	45
	575-3-60	518	632	—	14.40	—	62.0	2	2.3	—	20.7	—	35

**LEGEND**

- FLA** — Full Load Amps
- LRA** — Locked Rotor Amps
- MOCP** — Maximum Overcurrent Protective Device (see Note 1)
- NEC** — National Electrical Code
- RLA** — Rated Load Amps

\*Min Ckt Amps and MOCP Amps values per NEC (see Note 1)

†Indoor fan motors are single-phase motors of same voltage as the unit.

\*\*The overcurrent protective device for the unit shall be fuse only (see Note 1).

**NOTES:**

1. In compliance with NEC requirements for multimotor and combination load equipment (NEC Articles 430 and 440), the overcurrent protective device for the unit shall be either circuit breaker (where available) or fuse, except those units marked (\*\*), which shall be fuse only.
2. Wire sizing amps are a sum of 125% of the compressor RLA plus 100% of indoor fan motor FLA.
3. Motors are internally protected against primary single phasing condition.
4. Indoor fan motors are 3-phase motors of same voltage as unit, except those marked (†), which shall be single-phase motors of same voltage as the unit.
5. Three-phase voltage imbalance must not exceed 2%. See formula above.

## START-UP

### Unit Size 50BT,BU004 and 006

1. Thoroughly inspect exterior of unit. Clean any dust or debris with a mild solution of soap and water.
2. Set selector switch at OFF position and thermostat at highest setting.
3. Turn on unit power. On 50BT006 unit (if crankcase heater is utilized) and 50BU004 and 006 units, check that crankcase heater is on. Compressor shell in vicinity of heater should become warm to the touch.
4. On 50BT units, turn on condenser water supply. On 50BU units, open refrigerant line service valves.
5. Set selector switch at FAN position. Check fan speed (Table 1) and rotation. Fan direction arrow is attached to fan scroll. If fan requires adjustment, refer to Service, Indoor-Air Fan Adjustment.
6. Allow crankcase heater to remain energized (unit power on) for at least 24 hours; then set selector switch to COOL position and thermostat at lowest setting. Compressor will start.

UNIT 50BU006\_40 (3-Ph MODELS) ONLY — If compressor suction pressure does not drop, and discharge pressure does not rise to normal levels at start-up, reverse any 2 compressor power leads and restore power to ensure compressor was not wired to run in reverse direction.

7. Set thermostat at highest setting to shut off compressor.
8. On 50BU remote condenser units, the outdoor-air fans cycle with the compressor. Be sure fans are running during compressor operation.
9. Set thermostat for comfort as desired.

UNIT 50BU006\_40 MODELS ONLY — For fan motor to cycle with compressor, fan switch must be in FAN CYCLE position. For continuous fan operation, fan switch must be in FAN CONTINUOUS position.

Compressor switch must be in COOL ON position to energize compressor.

### ⚠ CAUTION

For 50BU006 scroll compressor models, a start assist is not supplied with single-phase models and is not required. If however, a field-supplied start thermistor is desired, a 12.5-ohm thermistor (Carrier part no. HC95XX009) is recommended. Connect the start thermistor in parallel with compressor run capacitor. Under NO circumstance should a *hard start kit* (capacitor and start relay) be installed, as damage to the scroll may result.

### Unit Size 50BT,BU008 and 012

1. Thoroughly inspect exterior of unit. Clean any dust or debris with a mild solution of soap and water.
2. *Open compressor discharge and suction service valves and liquid shutoff valves.*
3. With selector switch in OFF position, turn unit power on. On 50BT008 and 50BU008 and 012 units, leave unit in this condition for 24 hours so that crankcase heater can drive off any accumulated refrigerant.
4. Set selector switch at FAN position. Check fan speed (Table 1) and rotation. Fan direction arrow is attached to fan scroll. If fan requires adjustment, refer to Service, Indoor-Air Fan Adjustment.
5. Allow crankcase heater to remain energized (unit power on) for at least 24 hours; then set selector switch at COOL position and thermostat at lowest setting. Compressor will start.
6. Set thermostat at highest setting to shut off compressor.
7. On 50BU remote condenser units, the outdoor-air fans cycle with compressor. Be sure fans are running during compressor operation.
8. Set thermostat for comfort as desired.

### To Shut Down Unit

#### ALL UNITS

1. If unit may be exposed to freezing temperatures, drain water from condenser and all water piping (BT only).
2. Add a noncorrosive antifreeze to any residual water in the system (BT only).
3. Turn selector switch to OFF position. Do not shut off main power except to service unit. Crankcase heater on the 50BT006 (if utilized), the 50BT008 and on the 50BU004 - 012 units is operative only when unit power is on (see Service section, Crankcase Heater).
4. If unit is to be used for winter heating, set selector switch at FAN position and turn cooling thermostat off.

**Service Valves** — *Always be sure that compressor suction and discharge service valves and liquid shutoff valves are open before operating unit.*

The liquid shutoff valves are accessible from the front or rear of all units. To open valve, turn counterclockwise. After opening, replace and tighten valve cap to prevent leakage.

## SERVICE

### ⚠ DANGER

Never reach into unit while fan is running.

Lock open and tag fan motor power disconnect before working on a fan. Remove the fuses and take them with you after noting this on tag.

### ⚠ CAUTION

Before servicing fan compartment:

1. Sharp edges of evaporator coil fins are exposed. To prevent arm injury, cover top edge of evaporator with cardboard strip or a few layers of heavy tape.
2. To avoid coil damage, cover evaporator coil face with plywood or other rigid sheet material. If any coil fins are mashed or bent, straighten with a coil fin comb of the proper tooth spacing (see coil fins/ in. in Table 1). Check for refrigerant leaks.

**Indoor-Air Fan Adjustment** — Observe fan compartment Caution note above.

#### TO CHANGE FAN SPEED

1. Shut off unit power supply.
2. Loosen fan belt by loosening fan motor from mounting bracket. Do not loosen fan motor mounting bracket from unit.
3. Loosen movable pulley flange setscrew (Fig. 11).
4. Screw movable flange toward fixed flange to increase fan speed and away from fixed flange to decrease speed. Increasing fan speed increases load on motor. Do not exceed maximum allowable fan speed (Table 1) or motor full load amps indicated on motor nameplate and in Table 5.
5. Set movable flange setscrew at nearest flat of pulley hub and tighten setscrew.
6. Check pulley alignment and belt tension adjustment as described below.
7. Check fan operation. Repeat above procedure as required.

**PULLEY ALIGNMENT** — Shut off unit power supply. Loosen fan motor pulley setscrews and slide fan pulley along fan shaft. Make angular alignment by loosening motor from mounting bracket (see Fig. 11).

**BELT TENSION ADJUSTMENT** — Shut off unit power supply. Loosen fan motor from mounting bracket. Do not loosen motor mounting bracket from unit. Move fan motor up or down until proper belt tension is achieved (approximately  $\frac{3}{4}$ -in. deflection with 8-lb tension at midpoint of belt span).

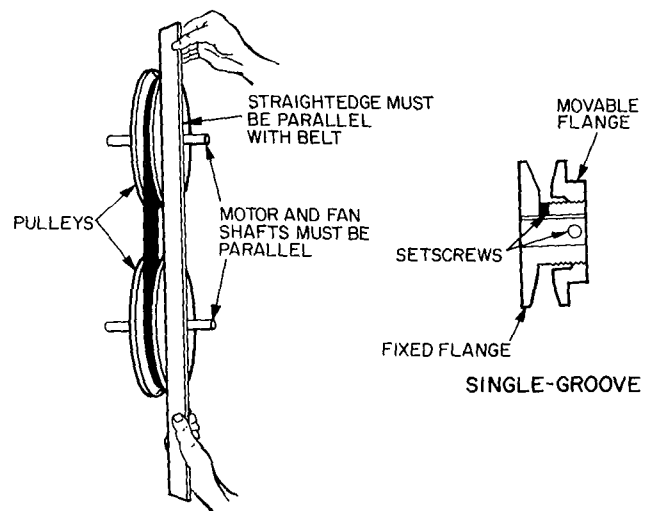

**Fig. 11 – Indoor-Air Fan Pulley Adjustment**

**Lubrication** — Observe fan compartment Caution note at the beginning of the Service section.

The fan motor bearings are factory lubricated and need no lubrication for the first 5 years of operation (3 years for continuous service or excessively dirty conditions). At that point, inspect fan motor bearings and relubricate as required. If heating coil is installed, oil bearings every 6 months. Follow lubrication instructions on special field-supplied motors.

Fan shaft bearings on 50BT, BU004-012 units are lubricated for the life of the bearings.

**Return-Air Filters** — Inspect filters twice monthly and replace as required by operating conditions. Filter size and type are listed in Table 1.

If cleanable filters are used, flush with hot water or steam or soak in a mild water solution of soap or detergent. Refer to filter manufacturer's instructions as applicable.

Do not operate unit without return-air filters. For access to filter, refer to Service, Access Panel Removal and Return-Air Grille Removal, as required.

**Condensate Drains** — Clean the drain line and unit drain pan at the start of each cooling season. Check flow by pouring water into drain. Be sure trap is filled as shown in Fig. 9 to maintain an air seal.

**Evaporator Coil** — Observe fan compartment Caution note at the beginning of the Service section.

Remove dirt and debris from evaporator coil as required by condition. Clean coil with a stiff brush, vacuum cleaner, or compressed air. Use a fin comb of the correct tooth spacing (see Table 1 for coil fins/in.) when straightening mashed or bent coil fins.

**Water-Cooled Condensers (50BT Units) —**  
 Condensers may require cleaning of water-deposited scale.

**CAUTION**

Follow all Safety codes. Wear safety glasses and rubber gloves when using inhibited hydrochloric acid solution.

Clean condensers with an inhibited hydrochloric acid solution. The acid can stain hands and clothing, attack concrete, and, without inhibitor, attack steel. Cover surroundings to guard against splashing. Vapors from vent pipe are not harmful, but take care to prevent liquid from being carried over by the gases.

Warm solution acts faster, but cold solution is just as effective if applied for a longer period.

**GRAVITY FLOW METHOD (Fig. 12) —** Do not add solution faster than vent can exhaust the generated gases.

When condenser is full, allow solution to remain overnight, then drain condenser and flush with clean water. Follow acid manufacturer's instructions.

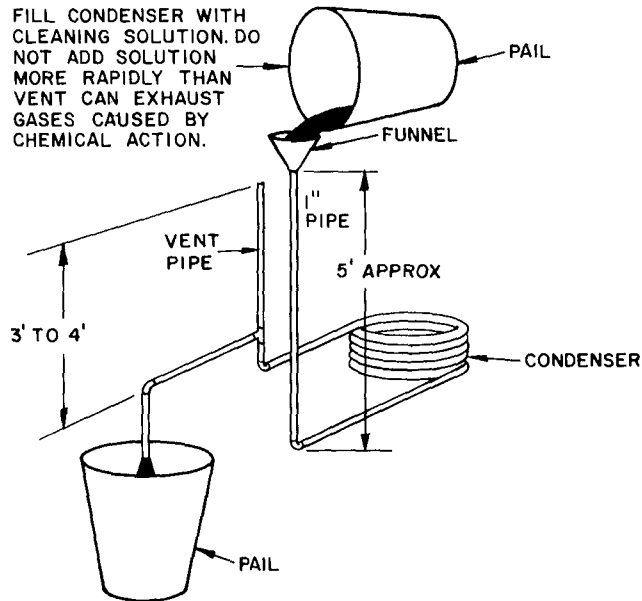
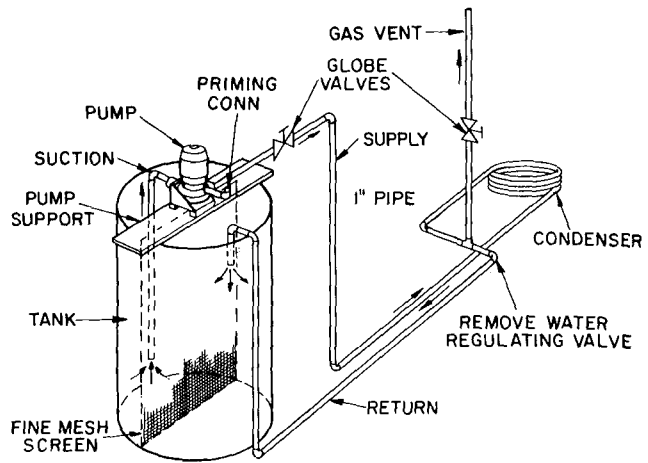

**Fig. 12 — Gravity Flow Method**

**FORCED CIRCULATION METHOD (Fig. 13) —** Fully open vent pipe when filling condenser. The vent may be closed when condenser is full and pump is operating.

Regulate flow to condenser with a supply line valve. If pump is a nonoverloading type, the valve may be fully closed while pump is running.

For average scale deposit, allow solution to remain in condenser overnight. For heavy scale deposit, allow 24 hours. Drain condenser and flush with clean water. Follow acid manufacturer's instructions.



**Fig. 13 — Forced Circulation Method**

**Air-Cooled Condensers (50BU Units) —** Inspect and clean periodically, depending upon operating conditions. Follow the service instructions provided for the make of condenser used.

**Charging the System —** On unit sizes 008 and 012, sight glasses are provided at inlet of each expansion valve, and are used in the field charging procedure.

NOTE: Water regulating valve (water-cooled condenser) or condenser airflow (air-cooled condenser) must be properly set before checking system charge.

UNIT SIZE 50BT004 AND 006 — These units, with water-cooled condensers, are shipped with full operating charge. If recharging is necessary:

1. Insert thermometer bulb in insulating rubber sleeve on liquid line near filter drier.
2. Add pressure gage to discharge line near compressor.
3. After unit conditions have stabilized, read head pressure on discharge line gage.
4. From standard Pressure-Temperature chart for R-22, find equivalent saturated condensing temperature.
5. Read liquid line temperature on thermometer; then subtract from saturated condensing temperature. The difference equals subcooling temperature.
6. Compare the subcooling temperature with the normal temperature listed in Table 6. If subcooling is low, add charge; if high, reclaim charge.

Example:

Head pressure (from gage) . . . . . 220 psig  
 Saturated condensing temp (from chart) . . . . . 108 F  
 Liquid line temp (from thermometer) . . . . . 96 F  
 Subcooling (by subtraction) . . . . . 12 F  
 (add charge)

**Table 6 — Subcooling Temperature**

UNIT	SUBCOOLING*
50BT004	20 ± 2° F
50BT006	20 ± 2° F

\*Saturated condensing temperature at compressor minus liquid line temperature.

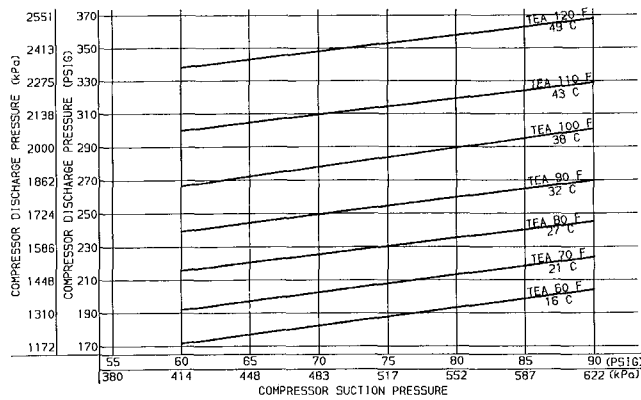

TEA — Temperature, Entering Air

Fig. 14 — Charging Chart, 50BU004

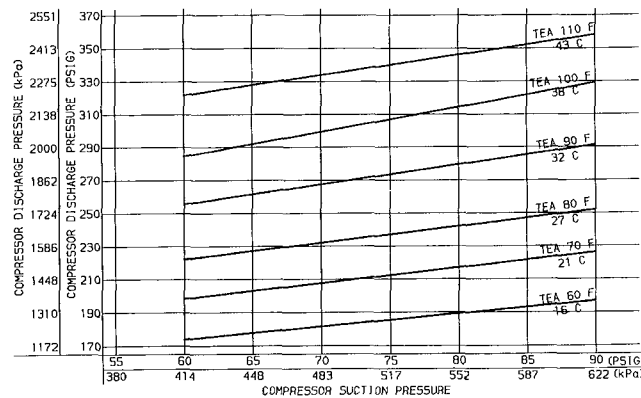

TEA — Temperature, Entering Air

Fig. 15 — Charging Chart, 50BU006

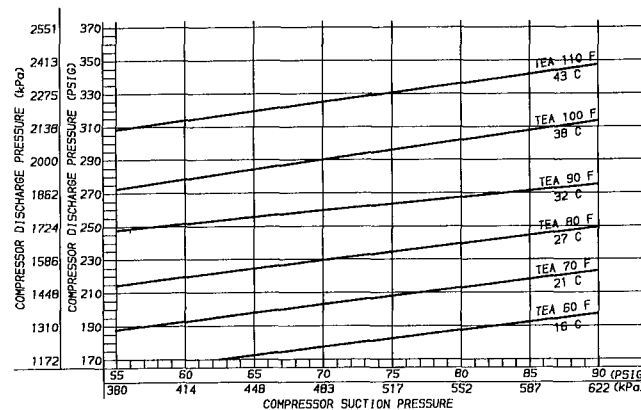

TEA — Temperature, Entering Air

Fig. 16 — Charging Chart, 50BU006\_40  
Scroll Compressor Unit Only

UNIT SIZE 50BU004 AND 006 — Refer to Charging the System, page 12, and Fig. 14-16 charging charts.

UNIT SIZE 50BT008 AND 012 — These units, with water-cooled condensers, are shipped with a full operating charge. If recharging is necessary (complete charge lost), weigh in amount of refrigerant indicated on unit nameplate and in Table 1.

If unit has partial charge, it may be charged with sight glass using standard charging techniques. Adjust the water regulating valve to maintain proper saturated condensing temperature (168 to 226 psig).

Refrigerant can be added to 50BT008 and 012 units after sight glass is cleared to take advantage of the condenser subcooling feature. Add refrigerant as follows:

50BT008 — 2.0 lb  
50BT012 — 1.5 lb

UNIT SIZE 50BU008 AND 012 — Refer to Charging the System, page 12.

### Return-Air Grille Removal

1. Pull grille out from top.
2. Pull grille up to release hinge pins from lower panel.
3. To reassemble, reverse procedure.

**Access Panel Removal** — On all units, remove return-air grille as described above.

Remove the panel fastening screws now exposed.

TOP PANEL — Pull out and down.

BOTTOM PANEL — Pull out and up.

### Indoor-Air Fan Motor Removal

#### ⚠ CAUTION

Before attempting to remove fan motors or motor mounts, place a piece of plywood over evaporator coils to prevent coil damage.

Motor power wires need not be disconnected from motor terminals before motor is removed from unit.

1. Shut off unit main power supply.
2. Loosen motor holddown bolts on mounting bracket so that fan belt can be removed.
3. Loosen but do not remove the 2 motor mounting bracket bolts on left side of bracket.
4. Slide motor/bracket assembly to extreme right and lift out through space between fan scroll and side frame. Rest motor on a high platform such as a step ladder. Do not allow motor to hang by its power wires.

**Pressure Relief Device** — All units are equipped with a fusible-plug type safety relief device on the refrigerant tubing. The relief setting is 197 F or 203 F on all units.

**Crankcase Heater** — A crankcase heater is supplied on all 50BU (condenserless) units and on 50BT008 water-cooled units.

The 50BT006 unit is also factory-supplied with a crankcase heater, but it is not electrically wired for use. To utilize the heater, a crankcase heater relay, part number HN61KB011 (460-v units) or HN61KX004 (all other units) must be field installed.

The heater prevents liquid refrigerant from accumulating in the compressor crankcase during extended shutdown periods. Heater is automatically energized whenever unit main power is on and compressor is stopped. Heater is de-energized when compressor starts.

Do not shut off main power supply for an extended period except for servicing unit. Turn on power supply for at least 24 hours after an extended shutdown before starting compressor. Refer to Start-Up section.

If 50BT004 and 012 units are installed in unheated rooms, they should be field equipped with crankcase heaters. For 50BT004 units, bellyband 40-watt heaters should be used. On 50BT012 units, use insertion 125-w heaters.

**Cycle-LOC™ Protection Device** — All units are equipped with Cycle-LOC current-sensing lockout relay. This device will lock out the compressor after any safety trip (high-pressure switch, low-pressure switch, or internal overload of the compressor). Check reason for lockout before resetting the device. Refer to unit label wiring diagram. To reset, turn the thermostat system switch to OFF, then back to COOL.

**Time Guard® II Control** — Model 50BU006340 is equipped with Time Guard II control, which provides a 5-minute time delay after unit is deenergized. This prevents reverse rotation of the compressor scroll after a brief power interruption.

**High and Low Pressurestats** — Refer to Table 1 for cut-in and cutout settings for these safety devices.

The high pressurestat is located on the compressor on 06DA compressor equipped units and on the discharge line on all other units. The low pressurestat is located on top of the compressor on 06DA compressor equipped units and on the suction line on all other units.

**Oil Charge** — All units are factory charged with oil (see Table 7). On 06D compressors, observe the oil level in the sight glass at start-up. If unit oil level is below sight glass, add oil until level reaches approximately ¼ sight glass.

If oil charge is above sight glass, do not remove any oil until the compressor crankcase heater has been energized for at least 24 hours.

When additional oil or a complete charge is required, use only Carrier-approved compressor oil.

Approved oils:

Petroleum Specialties, Inc. . . . . Cryol 150\*  
 Texaco, Inc. . . . . Capella WF-32  
 Witco Chemical Corp. . . . . Suniso 3GS

\*Factory oil charge.

Do not reuse any drained oil, and do not use any oil that has been exposed to the atmosphere.

**Table 7 — Oil Charge**  
 SEMI-HERMETIC COMPRESSORS

UNIT	OIL CHARGE (pt)
50BT, BU008	7.0
50BT, BU012	9.5

HERMETIC COMPRESSORS

UNIT	OIL RECHARGE (oz)	OIL TYPE*	
		Factory	Field
50BT, BU004	51	Suniso 3GS	Suniso 3GS
50BT006		or Calumet RO-15	
50BU006	62	Sontex 200 LT	

\*Hermetic compressors are factory charged with oil. If additional oil charge is required, use the recommended field oil type listed.

Copyright 1992 Carrier Corporation

**Manufacturer reserves the right to discontinue, or change at any time, specifications or designs without notice and without incurring obligations.**

Book | 1 | 4  
Tab | 2a | 7b

PC 111

Catalog No 565-057

Printed in U.S.A.

Form 50BT, BU-8SI

Pg 16

7-92

Replaces: 50BT, BU-6SI